

PowerLogic™

Electrical network management

Energy management, revenue metering
and power quality monitoring



www.schneider-electric.com



Life Is 

Schneider
Electric

Contents

Introduction to PowerLogic	3
Product panorama	7
Current transformers	15
Panel instruments	32
Basic energy metering IEM2000 series and IEM3000 series	43
Basic multi-function metering ION6200, PM3000 series, PM5350 and PM5000 series	58
Advanced metering PM8000 series and ION9000 series	104
Advanced utility metering ION7400, ION8650 and ION8800	127
Multi-circuit metering BCPM, EM4000 series, EM4800, and EM4900	157
Retrofit & wireless products EM3500, EM4200, EM4300, WT4100/4200	195
Communications and gateways Link150, Com'X 210, Com'X 510 and ION7550 RTU	209
Insulation monitoring devices Vigilohm insulation monitoring devices	236
Energy & power management edge control platforms EcoStruxure™ Power Management software EcoStruxure™ Power Monitoring Expert, EcoStruxure™ Power SCADA Operation	240
Commercial reference numbers	252

Clicking on a
**Commercial Reference
Number**
or scanning the product's
QR Code
links you to further product
information on
www.schneider-electric.com

PowerLogic™ System is...

Schneider Electric believes every business can increase productivity while consuming less and achieving energy savings of 10% to 30%.

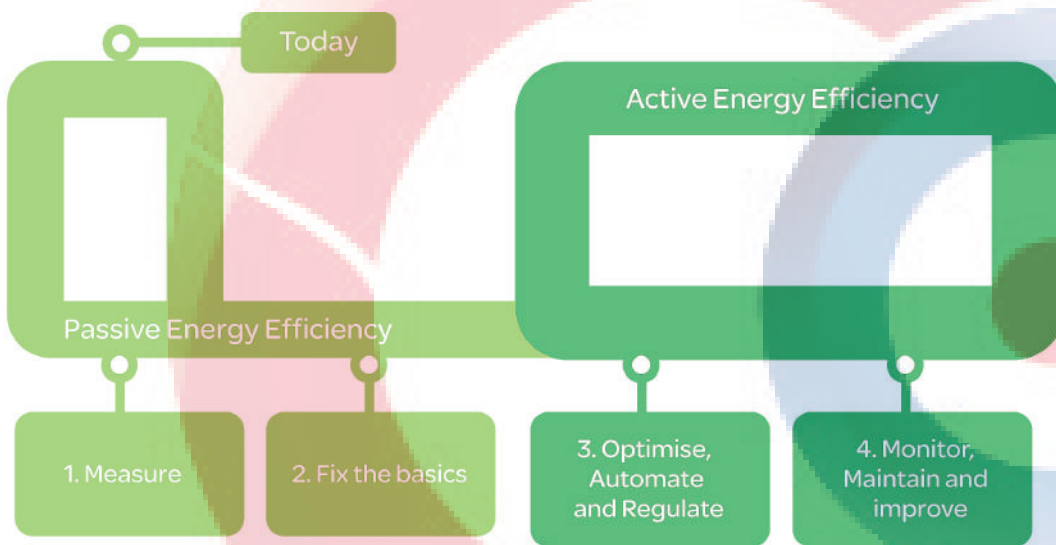

PowerLogic technology forms one part of your total energy management solution from Schneider Electric. As the global energy management specialist, we offer end-to-end power, building and process management solutions that help you optimize energy use and costs, improve performance, enhance comfort and safety, and deliver uninterrupted service while taking responsible care of our planet.

Saving energy reduces costs and pollution, but you need the tools to uncover all opportunities, avoid risks, track progress against goals, and verify success. Schneider Electric provides these tools via the world's most advanced energy intelligence technology: PowerLogic.

A PowerLogic system of meters, software and power quality solutions help manage all energy assets, every second of the day. A PowerLogic system enables all stakeholders, from CEO to facility and engineering managers, to respond quickly to potential problems and manage energy in financial and environmental terms.

PowerLogic technology delivers the key performance indicators and analytics that you need to strategically balance emissions, efficiency, reliability and cost.

Our expert services can help you audit your energy use and build your energy action plan. From power factor correction systems, harmonic filtering and variable speed drives to HVAC and lighting controls, we offer a complete range of energy efficient technologies.

optimizer

Gain energy insight and control with PowerLogic™ systems

Cutting-edge technology to increase profitability

PowerLogic technology converts the complex dynamics governing the relationship between power generation and distribution on the utility side, and energy consumption, cost and reliability on the consumer side, into timely, easily understood information. Businesses can use this powerful to improve tactical actions and strategic decision making.

From a single facility to an entire enterprise, PowerLogic meters monitor key distribution points 24 hours a day. Whether from generators, substations, service entrances, mains, feeders, loads or 3rd party equipment and systems, PowerLogic technology tracks, records and reports all real-time conditions and historical performance data. Intuitive web-based interfaces give stakeholders access to this data as well as advanced analytics, alarm annunciation and control capabilities. It supports comprehensive energy management programs by tracking performance and empowering you to make effective decisions.

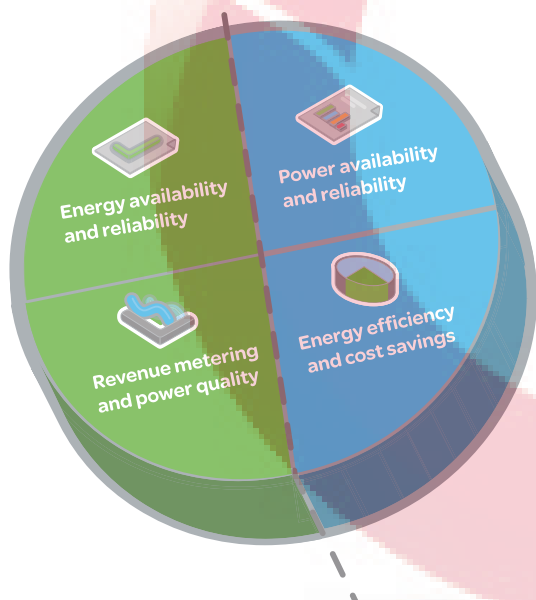

Demand

Power availability and reliability

- Validate that power quality complies with the energy contract
- Identify power quality issues and fix them quickly with reliable mitigation solutions
- Improve response to power-related problems
- Leverage existing infrastructure capacity and avoid over-building
- Support proactive maintenance to prolong asset life

Energy efficiency and cost savings

- Measure efficiency, reveal opportunities and verify savings
- Manage greenhouse gas emissions
- Allocate energy costs to departments or processes
- Reduce peak demand and power factor penalties
- Enable participation in loadcurtailment programs (e.g. demand response)
- Strengthen rate negotiation with energy suppliers
- Identify billing discrepancies
- Sub-bill tenants for energy costs

Supply

Energy availability and reliability

- Improve T&D network reliability
- Enhance substation automation
- Maximize the use of your existing infrastructure

Revenue metering and power quality

- Maximize metering accuracy at all interchange points
- Verify compliance with new power quality standards
- Analyse and isolate the source of power quality problems

Market segments

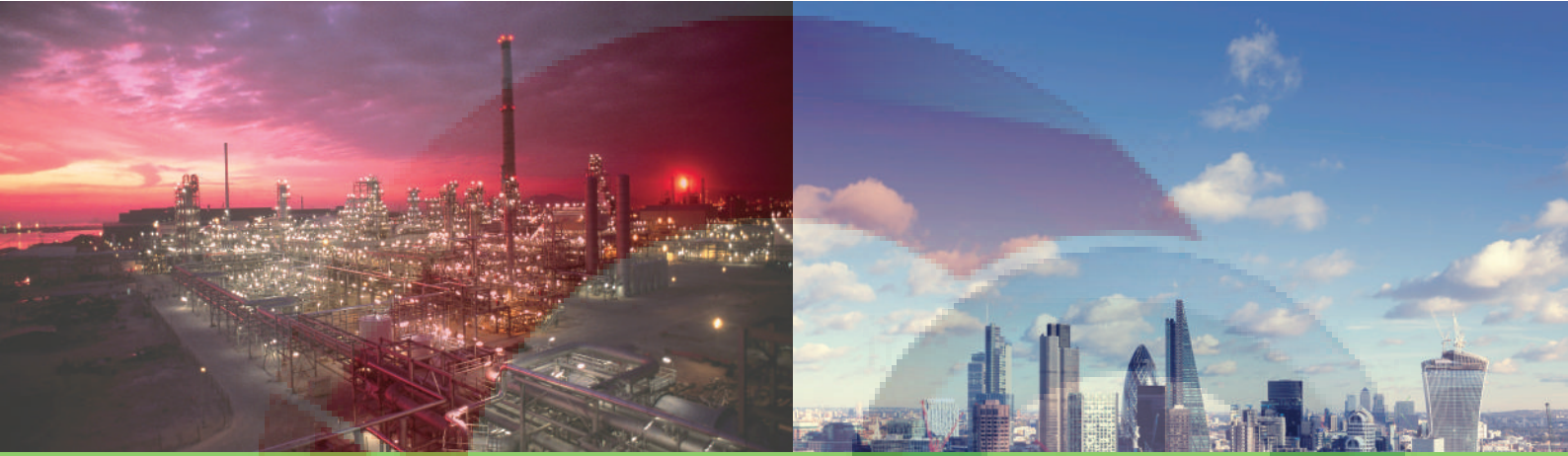

Industry

From finance to engineering, PowerLogic technology gives industry professionals the energy intelligence and control they need to support strategic decisions and establish best energy practices. It will help you reduce operational costs and meet new emissions standards without compromising production schedules or product quality.

Key points are monitored throughout your power distribution, building and backup systems. Enterprise-level software helps you maximize the use of your existing energy assets, increase energy efficiency and avoid demand or power factor penalties. Use it to uncover and solve hidden power problems that can shorten equipment life or cause costly downtime.

- Cost allocation
- Procurement optimization
- Power factor correction
- Continuity of service even in case of an earth fault

Buildings

Building managers through operations staff can cut energy and maintenance costs without effecting the comfort or productivity of their tenants, employees, students, patients or customers. A PowerLogic system will track all utilities and equipment conditions, and enterprise-level software will help you analyse and improve electrical reliability.

You can forecast energy requirements, optimize multi-site contracts and accurately allocate or sub-bill costs. Key performance indicators help you find and sustain energy savings, reduce emissions and meet “green” building standards in order to increase asset value and attract or retain tenants..

- Tenant sub-billing
- Cost allocation
- Energy efficiency & benchmarking
- Procurement optimization
- Power availability
- Demand response / load curtailment

optimizer



Utilities

Today's energy market is more complex than ever before. Whether you generate, transmit or distribute electricity, more stakeholders need shared access to timely, accurate energy data from more exchange points and you need to maintain power availability and reduce price volatility in the face of rising demand and transmission congestion. A PowerLogic energy information system helps you meet all of these challenges by:

- Metering all key interchange points with the highest possible accuracy
- Improving the quality of power delivered to your customers
- Ensuring the reliability and efficiency of your network and equipment

From advanced energy and power quality metering systems to enterprise-level analytic software and power quality mitigation solutions, PowerLogic systems deliver business-critical information that conventional metering, SCADA and billing systems cannot. It gives you the energy intelligence and control needed to track performance, stay informed of critical conditions and empower you to make strategic decisions. It will help you increase reliability, maximize the use of resources and improve service.

- Revenue metering
- Power quality monitoring
- Power availability and reliability
- Insulation monitoring

Critical infrastructure

PowerLogic technology helps keep your systems operating continuously and securely with an economical supply of energy. Whether you manage data, communication, transportation or environmental services, minimising the risk of power-related downtime and keeping costs under control is a priority.

A PowerLogic system monitors all power and cooling systems, accurately tracks their energy consumption, and allows you to identify and fix power quality issues as soon as they arise. Enterprise-level software delivers insightful diagnostics and metrics to help verify the reliability of your backup systems and maximize the use of existing capacity to defer new capital investments. You can also reveal energy inefficiencies and strengthen energy procurement across multiple sites.

- Infrastructure optimization
- Power quality analysis compliance
- Alarming and event notification
- Energy efficiency
- Cost allocation
- Procurement optimization



Panorama of the PowerLogic™ range

Whatever the size or type of application, this proven PowerLogic™ product line is a reliable and an integral part of any energy management and power monitoring system.

Use this panorama to select the most efficient products for your application needs.

optimizer

Panorama of the PowerLogic range

Current transformers



Panel Instruments

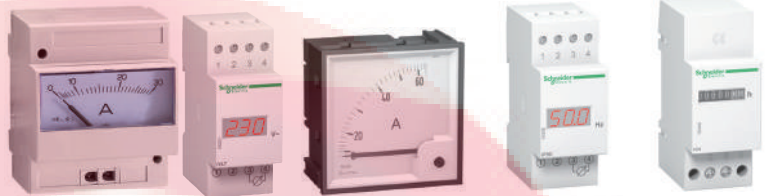

CTs Ip / 5 A	Name	iAMP	iVLT	AMP/VLT	iFRE	iCH/iCI
current transformer	Function	ammeter, voltmeter		ammeter, voltmeter	frequency meter	hour counter pulse counter
Installation ■ insulated cable, diameter 21 to 35 mm, through transformer ■ busbar through transformer ■ cable connections	Applications					
	Panel instrumentation					
	Panel instrumentation	I/U	I/U	I/U	F	hours/pulses
	Energy efficiency & cost					
	Sub-billing & cost allocation					
	Demand & load management					
Billing analysis						
Power availability & reliability						
Compliance monitoring						
Sag/swell, transient						
Harmonics						
Revenue metering						
Revenue meter						

Characteristics

- transformation ratio: 40/5 A to 6000/5 A
- accuracy: class 0.5 to 3
- maximum rated operational voltage: 720 V AC
- tropicalised

Characteristics

Measurement accuracy	Class 1.5	± 0.5 % ± 1 digit	Class 1.5	± 0.5 % ± 1 digit	
Installation	DIN rail 4 x 18 mm modules	DIN rail 2 x 18 mm modules	flush mounted 72 x 72 mm 96 x 96 mm	DIN rail 2 x 18 mm modules	iCI, iCH: DIN rail 2 x 18 mm modules CH: flush mount
Measurement	iAMP: 30 A direct or external CT	iVLT: 600 V AC direct or external VT	VLT: 500 V AC direct or external VT AMP: external CT	400 V AC direct	
Communication ports					
Inputs / Outputs					
Memory capacity					

page 15

page 33

page 33

page 33

page 33

page 33

Panorama of the PowerLogic range (cont'd)

Basic energy metering

Basic multi-function metering



Name	iEM2000/ iEM2010/ iEM2000T/ iEM2100	iEM3000 Series	ION6200	PM3000 Series	PM5350 Series
Function	kilowatt-hour meters	kilowatt-hour meters	metering & sub-metering Class 0.5S IEC 62053-22 Class 1 IEC 62053-21 Class 2 IEC 62053-23	metering & sub-metering Class 0.5S IEC 62053-22 Class 1 IEC 62053-21 Class 2 IEC 62053-23	Class 0.5S IEC 62053-22 Class IEC 62053-23 Class IEC 61557-12

Applications

Panel instrumentation

Panel instrumentation	E	I, U, F, P, Q, S, PF, E (Power demand and current demand)	I, U, F, P, Q, S, PF, E (Power demand and current demand)	I, U, F, P, Q, S, PF, E (Power demand and current demand)	I, U, F, P, Q, S, PF, E (Power demand and current demand)
-----------------------	---	--	--	--	--

Energy efficiency and cost

Sub-billing & cost allocation					
Demand & load management					
Billing analysis					

Power availability & reliability

Compliance monitoring					
Dip/swell, transient					
Harmonics					

Revenue metering

Revenue meter					
---------------	--	--	--	--	--

Characteristics

Measurement accuracy	Class 0.5S / Class 1	Class 0.5S / Class 1	Class 0.5S	Class 0.5	Class 0.5
Installation	DIN rail 1, 2, 5, or 7 x 18 mm modules	DIN rail	Flush mount or DIN rail	DIN rail	Flush mount 96 mm x 96 mm
Voltage measurement	400 V AC direct	50 V to 330 V (Ph-N) 80 V to 570 V (Ph-Ph) up to 1MV AC (ext VT)	60 V to 400 V AC L-N 103.5 to 690 V AC L-L	50 V to 330 V AC (Ph-N) 80 V to 570 V AC (Ph-Ph) up to 1MV AC (ext VT)	PM53xx 20-400 V L-N 20-690 V L-L
Current measurement	40 to 125 A direct or external CT	external CT	external CT	external CT	external CT
Communication ports		1	1	1	1
Inputs / Outputs		2 I/O	2 I/O	2 I/O	2 I/O
Memory capacity					

Link to:	page 44 MORE	page 51 MORE	page 59 MORE	page 66 MORE	page 72 MORE
----------	----------------------------------	----------------------------------	----------------------------------	----------------------------------	----------------------------------

Panorama of the PowerLogic range (cont'd)

Basic multi-function (contd) Advanced metering



Name	PM5000 Series	PM8000 Series	ION9000
Function	metering & sub-metering Class 0.5S IEC 62053-22 Class 0.2S (PM55xx) IEC 62053-22 Class 1/2 IEC 62053-24 IEC 61557-12	energy & basic power quality meter IEC 62053-22 Class 0.2S ANSI C12.20 Class 0.2 IEC 61000-4-30 Class S IEC 62586-2 IEC 61557-12 PMD/Sx/K70/0.2 IEC / UL 61010-1	energy & advanced power quality meter IEC 62053-22 Class 0.1S ANSI C12.20 Class 0.1 IEC 61000-4-30 Class A IEC 62586-1 / -2 IEC 61557-12 PMD/Sx/K70/0.2 IEC / UL 61010-1
Applications			
Panel instrumentation			
Panel instrumentation	I, U, F, P, Q, S, PF, E (Power demand and current demand)	I, U, F, P, Q, S, PF, E, THD, Min/Max, harm, alarm, I/O (I, U unbalance, demand, clock/cal, dip/swell)	I, U, F, P, Q, S, PF, E, THD, Min/Max, harm, alarm, I/O (I, U unbalance, demand, clock/cal, dip/swell, transients, flicker, RVC, mains signalling, 1/2 cycle RMS)
Energy efficiency and cost			
Sub-billing and cost allocation			
Demand and load management			
Billing analysis			
Power availability &			
Harmonics			
Dip/swell, transient		dip/swell	
Compliance monitoring			
Revenue metering			
Revenue metering			

Characteristics

Measurement accuracy (active energy)	Class 0.2S (PM55xx) Class 0.5S	IEC 62053-22 Class 0.2S ANSI C12.20 Class 0.2	IEC 62053-22 Class 0.1S ANSI C12.20 Class 0.1
Installation	Flush & DIN 96 mm x 96 mm	Flush & DIN 96 mm x 96 mm	Flush & DIN 160 mm x 160 mm Display 96 mm or 197 mm x 175 mm
Voltage measurement	20-400 V L-N 20-690 V L-L (PM55xx) 20-277 V L-N 35-690 V L-L (PM51/53xx)	57-400 V AC L-N 3P (100-690 V AC L-L)	57-400 V L-N AC or 100-690 V L-L AC
Current measurement	external CT	external CT	external CT
Communication ports	2	3	4
Inputs / Outputs	1DO for PM51xx 4/6 I/O PM53xx based on model 6 I/O for PM55xx	up to 27 DI, 9 DO up to 16 AI, 8 AO	up to 32 DI, 4 DO, 10 RO (relay) up to 16 AI, 8 AO
Memory capacity	256 kb 1.1 MB (PM55xx)	512 MB	2 GB

	page 95	page 106	page 116
Link to:	MORE	MORE	MORE

Panorama of the PowerLogic range (cont'd)

Advanced utility



Name	ION7400	ION8650	ION8800
		A B C	A B C
Function	energy & basic power quality meter IEC 61557-12 IEC 62053-22 IEC 61000-4-30 Class S IEC 62586 ANSI C12.20 Class 0.2 PMD/Sx/K70/0.2	energy & power quality meter IEC 62052-11 IEC 62053-22/23 Class 0.2S IEC 61000-4-30 Class A	energy & power quality meter IEC 62052-11 IEC 62053-22/23 Class 0.2S IEC 61000-4-30
Applications			
Panel instrumentation			
Panel instrumentation	I, U, F, P, Q, S, PF, E, THD, Min/Max, harm, alarm, I/O (I, U unbalance, demand, clock/cal)	I, U, F, P, Q, S, PF, E (demand, minimum and maximum values)	I, U, F, P, Q, S, PF, E (demand, minimum and maximum values)
Energy efficiency & cost			
Sub-billing and cost allocation			
Demand and load management			
Billing analysis			
Power availability & reliability			
Harmonics			
Dip/swell, transient	dip/swell		
Compliance monitoring			
Revenue metering			
Revenue metering			
Characteristics			
Measurement accuracy (active energy)	IEC 61053-22 Class 0.2S ANSI 12.20 Class 0.2S	Class 0.2S	Class 0.2S
Installation	Flush & DIN rail mount 96 mm x 96 mm	ANSI socket mount 9S, 35S, 36S, 39S and 76S; FT21 switchboard case	DIN 43862 rack
Voltage measurement	57-400 V AC L-N 3P (100-690 V AC L-L)	57-277 V L-N AC (9S, 36S); 120-480 V L-L AC (35S)	57-288 V L-N AC or 99-500 V L-L AC
Current measurement	external CT	external CT	external CT
Communication ports	2	5	5
Inputs / Outputs	up to 27 DI, 9 DO up to 16 AI, 8 AO	up to 22 I/O	up to 16 I/O
Memory capacity	512 MB	10 MB 4 MB 2 MB	up to 10 MB
Link to:	page 128 MORE	page 138 MORE	page 148 MORE

Panorama of the PowerLogic range (cont'd)

Multi-circuit metering



Name	BCPM	EM4000	EM4800	EM4900
Function	branch circuit monitor IEC 61036 Class 1	multi-circuit energy meter Class 0.5 ANSI C12.1, C12.20 Class 0.5S IEC 62053-22	multi-circuit energy meter Class 0.5 ANSI C12.1, C12.20 Class 0.5S IEC 62053-22	multi-circuit energy meter Class 0.5 ANSI C12.1, C12.20 Class 0.5S IEC 62

Applications

Panel instrumentation

Panel instrumentation	I, U, F, P, Q, S, PF, E (Power demand and current demand)	I, U, F, P, Q, S, PF, E (Power demand and current demand)	I, U, F, P, Q, S, PF, E (Power demand and current demand)	I, U, F, P, Q, S, PF, E (Power demand and current demand)
-----------------------	--	--	--	--

Energy efficiency and cost

Sub-billing and cost allocation				
Demand and load management				
Billing analysis				

Power availability and reliability

Compliance monitoring				
Sag/swell, transient				
Harmonics				

Revenue metering

Revenue meter				
---------------	--	--	--	--

Characteristics

Measurement accuracy	Class 1 (mains active energy)	Class 0.5S	Class 0.5S	Class 0.5S
Installation	Panel or enclosure	Panel or enclosure	Panel or enclosure	Panel or enclosure
Voltage measurement	90 – 277 V L-N voltage Inputs	80 - 480 V AC L-L without PTs, Up to 999 kV with external PTs	80 - 480 V AC L-L without PTs, Up to 999 kV with external PTs	150 – 480 V AC L-L without PTs, Up to 999 kV with external PTs
Current measurement	CT strips for branch circuits and external CTs for mains	Split- or solid-core CTs	Split- or solid-core CTs	Split- or solid-core CTs
Communication ports	1 for main	2	2	2
Inputs / Outputs		2	2	2
Memory capacity				

page 158

[MORE](#)

page 172

[MORE](#)

page 181

[MORE](#)

page 186

[MORE](#)

Panorama of the PowerLogic range (cont'd)

Retrofit & wireless products



Name	EM3500	EM4200
Function	DIN rail power & energy meter ANSI 12.20 0.2% accuracy, IEC 62053-22 Class 0.2S for EM35xx models, ANSI C12.20 0.5% accuracy, IEC 62053-22 Class 0.2S for EM35xxA models	power & energy meter ANSI C12.20 0.2% IEC 62053-22 Class 0.2S

Applications

Panel instrumentation

Panel instrumentation	I, U, F, P, Q, S, PF, E (Power demand and current demand)	I, U, F, P, Q, S, PF, E (Power demand and current demand)
-----------------------	--	--

Energy efficiency and cost

Sub-billing and cost allocation		
Demand and load management		
Billing analysis		

Power availability and reliability

Compliance monitoring		
Sag/swell, transient		
Harmonics		

Revenue metering

Revenue meter		
---------------	--	--

Characteristics

Measurement accuracy	Class 1 (mains active energy)	ANSI C12.20 Class 0.2S IEC 62053-22 Class 0.2S
Installation	Panel or enclosure	DIN or screw, clip-on or hook
Voltage measurement	UL: 90 V L-N to 600 V L-L; CE: 90 V L-N to 300 V L	890 - 480 V AC L-L
Current measurement	EM35xxA models work exclusively with Rogowski coil CTs.	5 A to 5000 A
Communication ports	1 for main	2
Inputs/Outputs	(see Datasheet)	
Memory capacity		

Link to:	page 197 MORE	page 203 MORE
----------	-------------------------------	-------------------------------

Panorama of the PowerLogic range (cont'd)

Communications & gateways

Insulation monitoring Devices

Monitoring software



Name	Link150	Com'X 210 Com'X 510	ION7550 RTU	Vigilohm™ Insulation monitoring devices	EcoStruxure™ Energy & power management software
Function	Modbus Serial to Modbus TCP/IP protocol gateway	Modbus gateway plus Energy Server and Cloud connector	Ethernet gateway-server + onboard I/O	Insulation monitoring for IT / Ungrounded networks	Power management, network protection and control

Features

Features	Ethernet Gateway	Ethernet Gateway	Ethernet Gateway	RS-485	EcoStruxure™ Power Monitoring Expert, EcoStruxure™ Power SCADA Operation
RS-485 / Ethernet gateway	Ethernet Gateway	Ethernet Gateway	Ethernet Gateway	RS-485	EcoStruxure™ Power Monitoring Expert, EcoStruxure™ Power SCADA Operation
Devices supported	All Modbus devices	100+ known Schneider Electric devices and the ability to create custom Modbus models. EM3000 Series, iEM3000 Series, Acti9 Smartlink Masterpact, PM5000 Series, Compact NSX, iEM1, iEM2000 series, PM3000 Series, PM5350, PM5000, PM8000, ION9000, CM4000	ION8800, ION9000, Modbus devices PM5350 PM5000 PM8000	Insulation Monitors: IM9, IM9-OL, IM10, IM20 IM10-H, IM20-H, IM400 series IM400THR Insulation Fault Locators: IFL 12, IFL 12C, IFL 12MC, IFL 12H Accessories: Including voltage adaptors, cardews, toroids	100+ Schneider Electric devices
Web server with standard HTML pages	Configuration only	Com'X 510 - full support Com'X 210 - config. only			
Web server with custom HTML pages		Custom web page support			
Real time data		Available on Com'X 510			
Historical data		Com'X 510 onboard storage Com'X 210 - publish to database server			
Automatic notification		Event Notification to FI			
Alarm and event logs					
Waveform display			RTU includes alarm and event logs		
Custom animated graphics					
Manual/automatic reports					

Characteristics

Ethernet ports	2 (switch mode only)	2	10/100 Base TX port		
Modbus TCP/IP protocol					
RS-485 (2-wire / 4-wire) ports, Modbus protocol	2w/4w - 1 (rj45)	1	3		
Number of devices connected directly	32	64 devices/32 max Modbus, 2 analog sensors	64		
RS-232 configuration ports	1		1		
Miscellaneous	Serial line to Ethernet connectivity - serial or Ethernet master	Connectivity: WiFi, Ethernet, Zigbee, GPRS, + 3G	modem port I/O (20 I / 12 O)		
Installation	9 DIN rail	DIN rail	DIN 192 cutout 186 x 186 mm		

An IT earthing system -also called ungrounded system- allows the network to operate even in the presence of an insulation fault, without endangering people or property. Required as part of the IT network, an Insulation Monitoring Device (IMD) detects the insulation fault and locates it so it can be repaired.

EcoStruxure™ is an architecture of interoperable, and scalable supervisory software dedicated to power monitoring that enables you to maximize operational efficiency, optimize power distribution systems, and improve bottom-line performance.

Link to:	page 213 MORE	page 217 MORE	page 227 MORE	page 241	page 247
----------	-------------------------------	-------------------------------	-------------------------------	--------------------------	--------------------------

Current transformers

Schneider Electric is the global specialist in energy management with the most complete power monitoring product line. Current Transformers are essential components designed to be used with Schneider Electric's extensive power monitoring product portfolio. From simple energy meters to world class power quality meters, these proven products satisfy any requirement.



056854NMD-2
 056852NMD-2
 PB100316-35
 PB119864
 PB119870

optimizer



METSECT5CC04



METSECT5MB025



METSECT5CYL1



METSECT5GD025



METSECT5HA025

Ip/5 A ratio

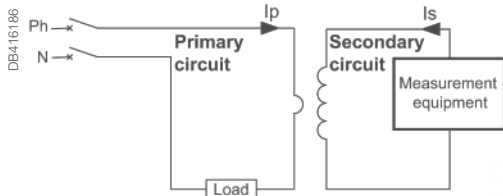

Application diagram of a CT.

The Ip/5 A ratio current transformer delivers at the secondary a current (I_s) of 0 to 5 A that is proportional to the current measured at the primary (I_p). This allows them to be used in combination with measurement equipment:

- Ammeters.
- Kilowatt-hour meters.
- Measurement units.
- Control relays.
- etc.

When the primary is energized, the measurement equipment nearly acts as a short circuit which keeps the secondary voltage very low. This voltage will increase significantly if the short circuit is removed.

CT selection - conductor rating aspects

The choice depends on the conductor profile and the maximum intensity of the primary circuit.

CT with let-through primary

Conductor type	Cable	Mixed, bars or cables	Vertical or horizontal bars	Vertical bars
Suggested Current Transformer and mounting	DB415986	DB415920	DB415988	DB415989
Ratings (A)	40 to 250	150 to 800	200 to 4000	5000 to 6000
CT internal	Type C	Type M	Type D ⁽¹⁾	Type V
	FF C	FF MA FF MD	FF D	FF V

(1) Two secondary connectors (parallel internal wiring - only one secondary winding) for easier cable access. 1 lateral + 1 on one extremity. Warning: only one must be used at a time.

Specific mounting: use of cylinder

A cylindrical metallic spacer ensures a proper CT positioning when the conductor or the CT cannot be positioned perpendicular. Secured by bolt + nut.

CT with primary connection by screw and nut (example: use of cylinder with bar or cable)

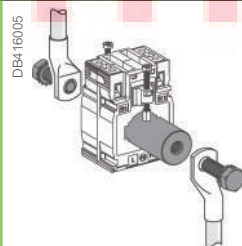

METSECT5CYL1 (aluminium)

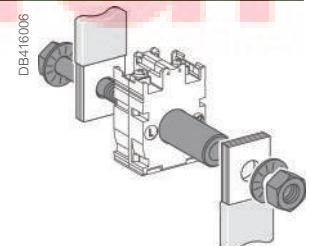

16550 (brass)

NOTE: This document is not intended to be used as an installation guide.

CT selection - Electrical aspect Ip/5 A

- We recommend that you choose the ratio immediately higher than the maximum measured current (In).
Example: In = 1103 A; ratio chosen = 1250/5.
- For small ratings: From 40/5 to 75/5 and for an application with digital devices, we recommend that you choose a higher rating, for example 100/5. This is because small ratings are less accurate and the 40 A measurement, for example, will be more accurate with a 100/5 CT than with a 40/5 CT.
- Specific case of the motor starter: to measure motor starter current, you must choose a CT with primary current $I_p = I_d/2$ (I_d = motor starting current).

Validation of measurement solution according to accuracy class

It consists in controlling the right adaptation of the CT on the accuracy class aspect. The accuracy class is specified in the project. The total dissipated power of the measurement circuit (meter + cables) should not be superior to the specified limit of the CT. This limit is for different standard classes. If necessary, the choice of the cable section, the CT or meter should be modified to fit the requirement.

Copper cable cross-section (mm ²)	Power per doubled meter at 20 °C (VA)	Schneider Electric device	Consumption of the current input (VA)
1	1	Ammeter 72 x 72 / 96 x 96	1.1
1.5	0.685	Analog ammeter	1.1
2.5	0.41	Digital ammeter	0.3
4	0.254	PM8000	0.15
6	0.169	PM3000	0.3
10	0.0975	PM5000	
16	0.062	iEM3000	

For each temperature variation per 10 °C bracket, the power drawn up by the cables increases by 4 %.

Application example

Project specification: **200 A**, in **Ø27** mm cable, accuracy class 1.
Our choice is **METSECT5MA020**.

For this CT selected on the chart (next page), the max acceptable power is **7 VA** (for "Accuracy class 1" which is specified in the project).

Internal profile type	Cables (mm)	Bars (mm)	Rating Ip/5 A (A)	Commercial reference number	Accuracy class		
					0.5	1	3
					Max. power (VA)		
	Ø27	10 x 32	150	METSECT5MA015	3	4	-
			200	METSECT5MA020	4	7	-
			250	METSECT5MA025	6	8	-
			300	METSECT5MA030	8	10	-
			400	METSECT5MA040	10	12	-

- Control of the conformity of the measurement chain:
- PM3000 multi-meter: 0.3 VA.
 - 4 meters of 2.5 mm², doubled wires: 0.41 x 4 = 1.64 VA.
- Total: 0.3 + 1.64 = 1.94 VA (< 7 VA)**

Conclusion: this CT is well adapted as the accuracy class will be even better than 1.

⚠ DANGER

HAZARD OF ELECTRIC SHOCK, EXPLOSION, OR ARC FLASH

- Apply appropriate personal protective equipment (PPE) and follow safe electrical work practices. See NFPA 70E in the USA, CSA Z462 or applicable local standards.
- Turn off all power supplying this device and the equipment in which it is installed before working on the device or equipment.
- Always use a properly rated voltage sensing device to confirm that all power is off.
- Treat I/O wiring connected to multiple devices as hazardous live until determined otherwise.
- Do not exceed the device's ratings for maximum limits.
- Do not use this device for critical control or protection applications where human or equipment safety relies on the operation of the control circuit.
- Disconnect all the device's input and output wires before performing dielectric (hi-pot) or Megger testing.

CT DAMAGE

- Never open circuit a current transformer (CT)
- Do not open the CT case.
- Do not attempt to repair any components of the CT.

Failure to follow these instructions will result in death or serious injury.

PB118085

Presentation of commercial reference numbers

MET SE CT **X** **XX** **XXX**

1 = 1 Amp
5 = 5 Amp
R = Rogowski

Last 3 digits = primary rating/10
2 letters = Form Factor

Examples:

METSECT5CC008 = 5 A secondary, Cables only, 75 A primary
METSECT5MC080 = 5 A secondary, mixed for cables and bars, 800 A primary
METSECTR30500 = Rogowski CT, 300 mm length, 96 mm diameter 50 A to 5000 A



METSECT5CC●●●

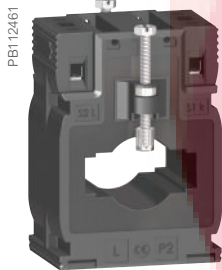

METSECT5MB●●●

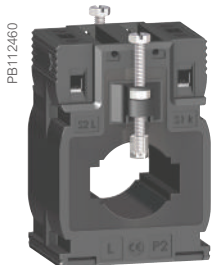

METSECT5MA●●●

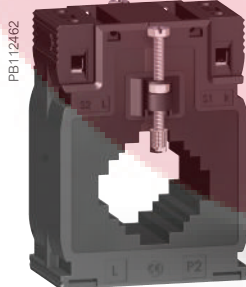

METSECT5MC●●●

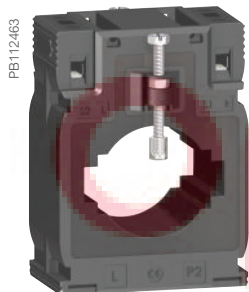

METSECT5MD●●●

Type C - solid core current transformer (cable profile)				
Internal profile type	Cables (mm)	Bars (mm)	Rating Ip/5 A (A)	Commercial ref number
CC				
FFCC	Ø21	-	40	METSECT5CC004
			50	METSECT5CC005
			60	METSECT5CC006
			75	METSECT5CC008
			100	METSECT5CC010
			125	METSECT5CC013
			150	METSECT5CC015
200	METSECT5CC020			
250	METSECT5CC025			

Type M - current transformers (mixed: cable/bar profile)				
MB				
FFMB	Ø26	12 x 40 15 x 32	250	METSECT5MB025
			300	METSECT5MB030
			400	METSECT5MB040
MA				
FFMA	Ø27	10 x 32 15 x 25	150	METSECT5MA015
			200	METSECT5MA020
			250	METSECT5MA025
			300	METSECT5MA030
400	METSECT5MA040			
MC				
FFMC	Ø32	10 x 40 20 x 32 25 x 25	250	METSECT5MC025
			300	METSECT5MC030
			400	METSECT5MC040
			500	METSECT5MC050
			600	METSECT5MC060
			800	METSECT5MC080
MD				
FFMD	Ø40	12 x 50 20 x 40	500	METSECT5MD050
			600	METSECT5MD060
			800	METSECT5MD080

See your Schneider Electric representative for complete ordering information.

optimizer

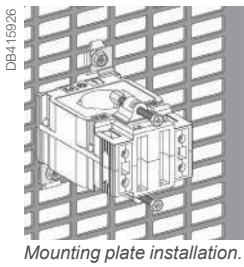

Mounting plate installation.

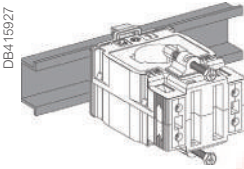

DIN rail mounting.

Common characteristics

Secondary current I _s (A)	5 A
Maximum voltage rating U _e (V)	720 V
Frequency (Hz)	50/60 Hz
Safety factor (sf)	40 to 4000 A: sf ≤ 5 5000 to 6000 A: sf ≤ 10
Degree of protection	IP20
Operating temperature	tropicalised range -25°C to +60°C ⁽¹⁾ relative humidity > 95 %
Storage temperature	-40°C to +85°C
Compliance with standards	IEC 61869-2 VDE 0414
Secondary connection (as per model)	by terminals for lug by tunnel terminals by screws

(1) Warning: some products are limited to +50°C.

Type C - solid core current transformer (cable profile)

Internal profile type	Accuracy class			Overall dimensions (refer to drawing pages for details) W x H x D (mm)	Fastening mode	Accessories Cylinder		
	0.5	1	3					
Max. power (VA)								
CC								
FF CC 	Dimension (mm)			44 x 66 x 37	<ul style="list-style-type: none"> ■ Adapter for DIN rails. ■ Mounting plate. 		16550 METSECT5CYL1	Included
	-	-	1					
	-	1.25	1.5					
	-	1.25	2					
	-	1.5	2.5					
	2	2.5	3.5					
	2.5	3.5	4					
	3	4	5					
4	5.5	6						
5	6	7						
MB								
FF MB 	3	5	-	60 x 85 x 63	<ul style="list-style-type: none"> ■ Adapter for DIN rails. ■ Mounting plate. 	-	-	METSECT5COVER
	4	6	-					
	6	8	-					
MA								
FF MA 	3	4	-	56 x 80 x 63	<ul style="list-style-type: none"> ■ Adapter for DIN rails. ■ Mounting plate. 	METSECT5CYL2	METSECT5COVER	
	4	7	-					
	6	8	-					
	8	10	-					
	10	12	-					
MC								
FF MC 	3	5	-	70 x 95 x 65	<ul style="list-style-type: none"> ■ Adapter for DIN rails. ■ Mounting plate. 	-	METSECT5COVER	
	5	8	-					
	8	10	-					
	10	12	-					
	12	15	-					
	10	12	-					
MD								
FF MD 	4	6	-	70 x 95 x 65	<ul style="list-style-type: none"> ■ Adapter for DIN rails. ■ Mounting plate. 	-	METSECT5COVER	
	6	8	-					
	8	12	-					

See your Schneider Electric representative for complete ordering information.

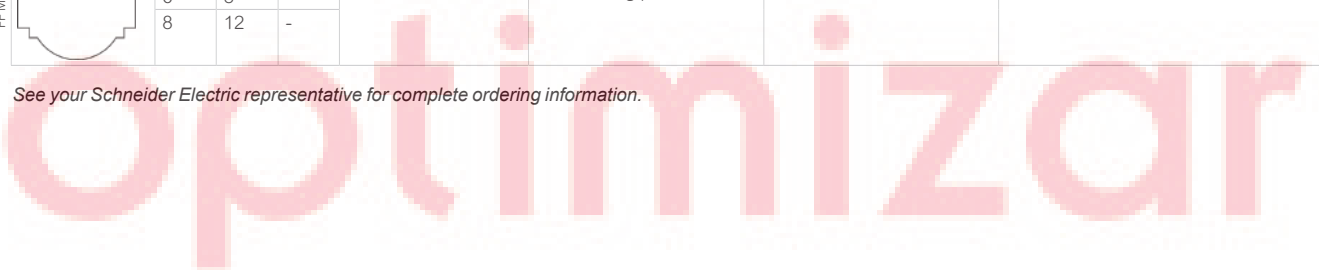

NOTE: This document is not intended to be used as an installation guide.

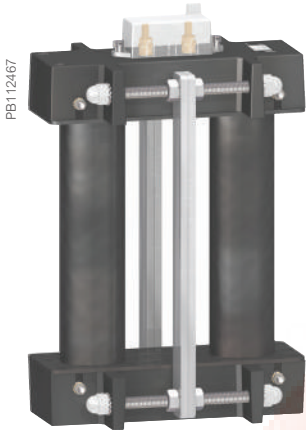

METSECT5VV●●●

Type V - current transformers (vertical bar profile)

Internal profile type	Cables (mm)	Bars (mm)	Rating Ip/5 A (A)	Commercial reference number
VV				
FF V2	-	55 x 165	5000	METSECT5VV500 ★
			6000	METSECT5VV600 ★

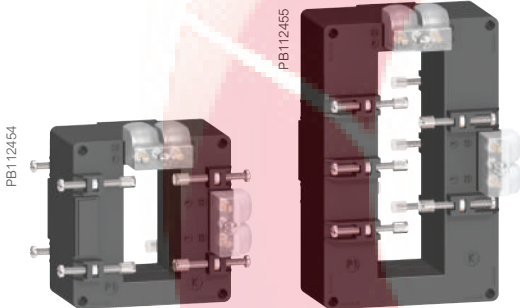

METSECT5DA●●●

METSECT5DB●●●

Type D - current transformers (vertical or horizontal bar - dual secondary terminals)

DA				
	-	32 x 65	400	METSECT5DA040
			500	METSECT5DA050
			600	METSECT5DA060
			800	METSECT5DA080
			1000	METSECT5DA100
			1250	METSECT5DA125 ★
1500	METSECT5DA150 ★			
DB				
	-	38 x 127	1000	METSECT5DB100
			1250	METSECT5DB125 ★
			1500	METSECT5DB150 ★
			2000	METSECT5DB200 ★
			2500	METSECT5DB250 ★
3000	METSECT5DB300 ★			
DC				
	-	52 x 127	2000	METSECT5DC200 ★
			2500	METSECT5DC250 ★
			3000	METSECT5DC300 ★
			4000	METSECT5DC400 ★
DD				
	-	34 x 84	1000	METSECT5DD100
			1250	METSECT5DD125 ★
			1500	METSECT5DD150 ★
DE				
	-	54 x 102	1000	METSECT5DE100
			1250	METSECT5DE125 ★
			1500	METSECT5DE150 ★
			2000	METSECT5DE200 ★
DH				
	-	38 x 102	1250	METSECT5DH125 ★
			1500	METSECT5DH150 ★
			2000	METSECT5DH200 ★

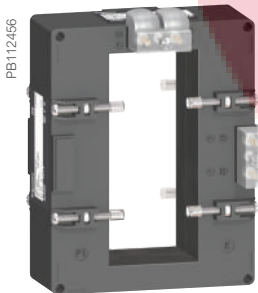

METSECT5DC●●●

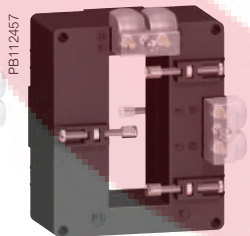

METSECT5DD●●●

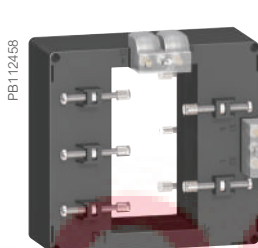

METSECT5DE●●●

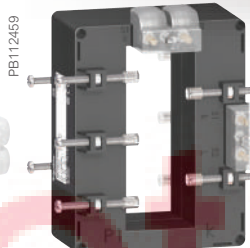

METSECT5DH●●●

★ Operating temperature: -25 °C to 50 °C

See your Schneider Electric representative for complete ordering information.

Type V - solid core current transformers (vertical bar profile)

Internal profile type	Accuracy class			Overall dimensions (refer to drawing pages for details) W x H x D (mm)	Fastening mode	Accessories	
	0.5	1	3			Cylinder	Sealable cover
	Max. power (VA)						
VV	Dimension (mm)						
FF VZ 	60	-	-	175 x 273.5 x 110	■ Insulated locking screw.	-	Included
	70	-	-				

Type D - solid core current transformers (vertical or horizontal bar - dual secondary terminals)

DA	Dimension (mm)			Fastening mode	Accessories	Sealable cover
	4	8	-			
	8	10	-			
	8	12	-			
	12	15	-			
	15	20	-			
	15	20	-			
	20	25	-			
DB	6	10	-	■ Insulated locking screw.	-	Included
	8	12	-			
	10	15	-			
	15	20	-			
	20	25	-			
	25	30	-			
DC	25	30	-	■ Insulated locking screw.	-	Included
	30	50	-			
	30	50	-			
	30	50	-			
DD	10	15	-	■ Insulated locking screw.	-	Included
	12	15	-			
	15	20	-			
DE	12	15	-	■ Insulated locking screw.	-	Included
	15	20	-			
	20	25	-			
	20	25	-			
DH	12	15	-	■ Insulated locking screw.	-	Included
	12	15	-			
	20	25	-			

★ Operating temperature: -25 °C to 50 °C

See your Schneider Electric representative for complete ordering information.

optimizer

Solid core CT dimensions

CC internal profile type

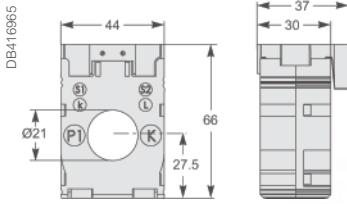

MB internal profile type

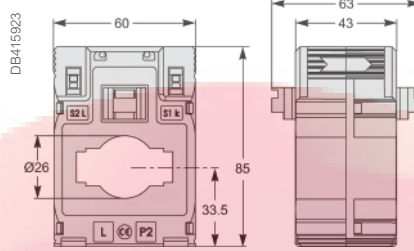

MA internal profile type

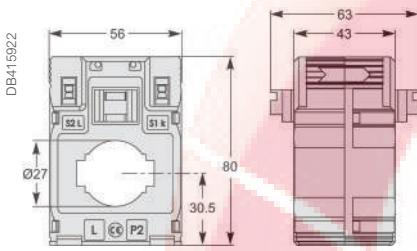

MC internal profile type

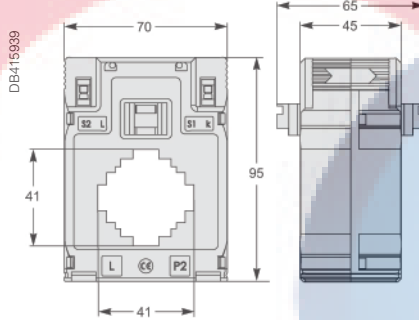

MD internal profile type

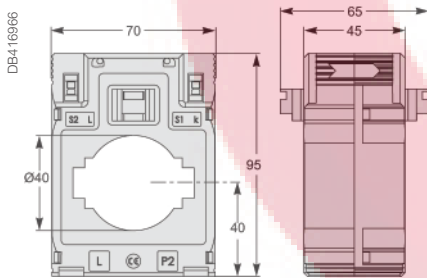

DA internal profile type

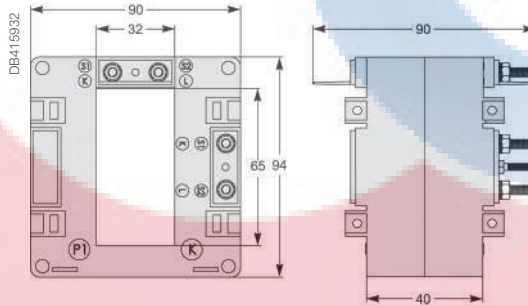

DB internal profile type

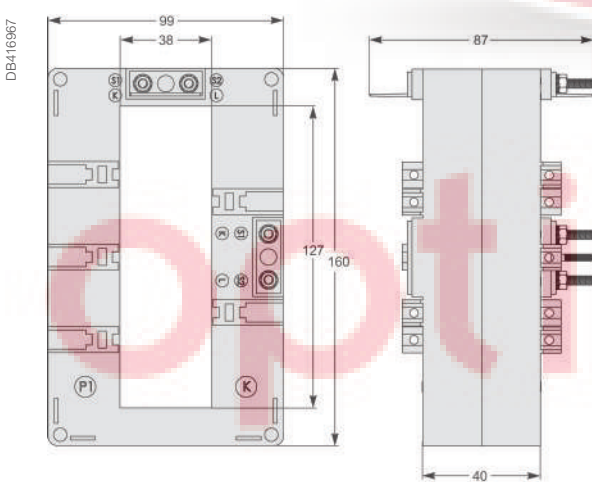

DC internal profile type

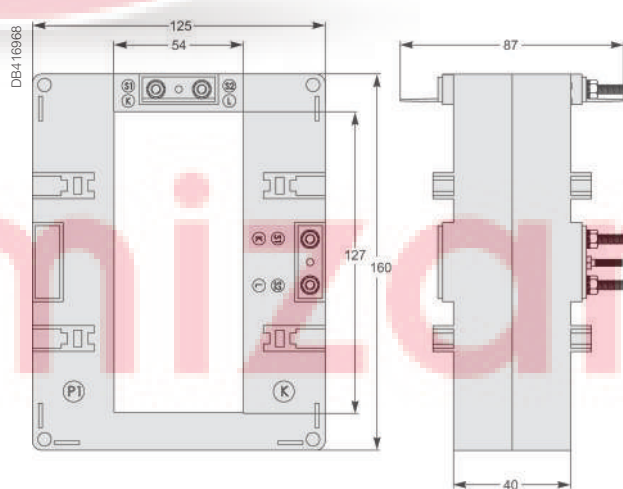

Solid core CT dimensions contd.

DD internal profile type

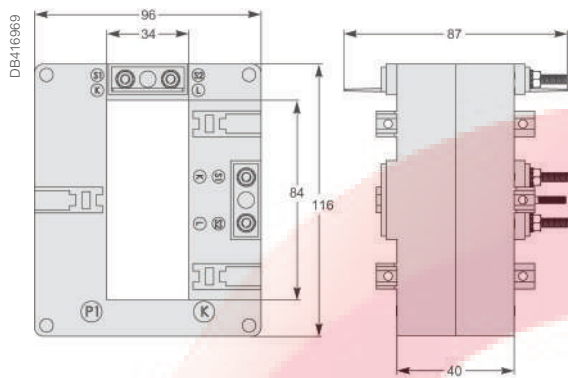

DE internal profile type

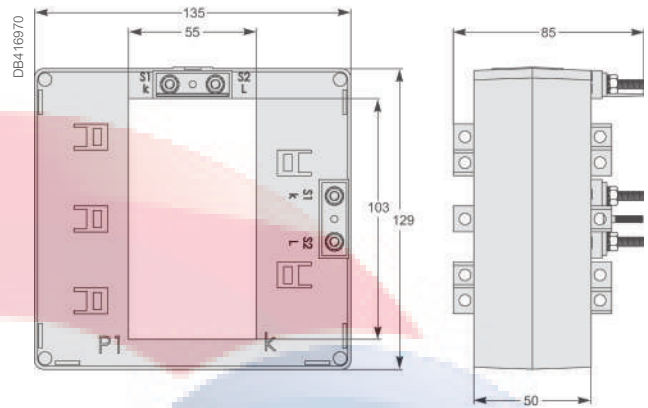

DH internal profile type

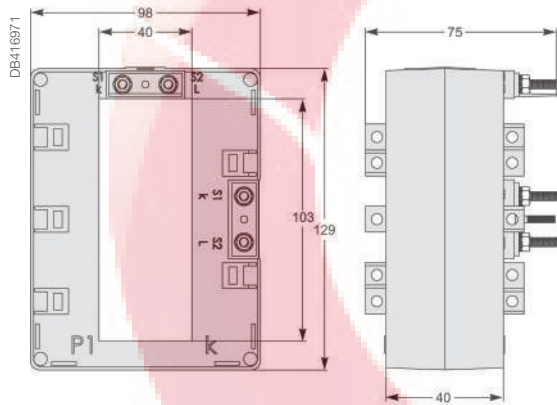

VV internal profile type

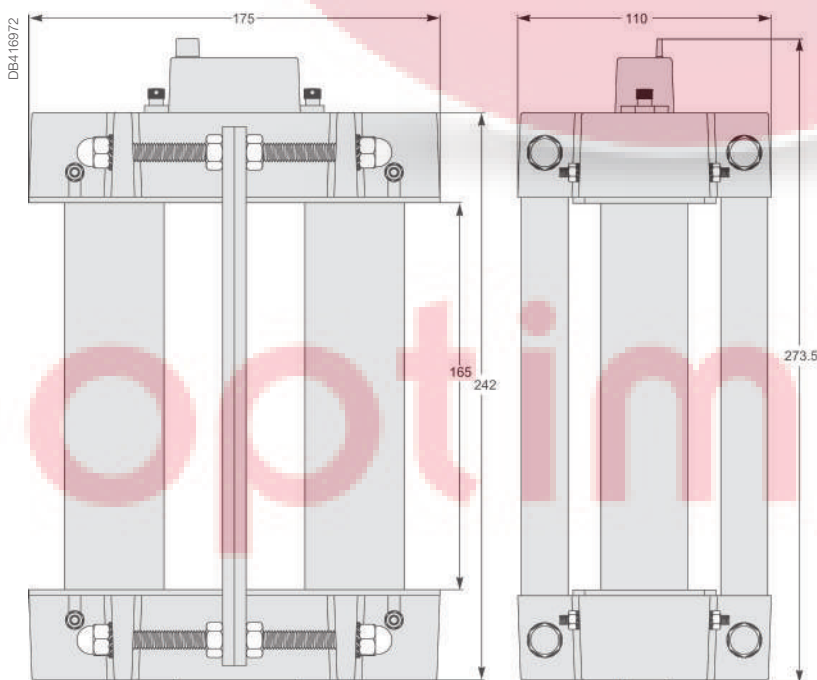

NOTE: This document is not intended to be used as an installation guide.

Solid core cylinders dimensions

Cylinders

METSECT5CYL1

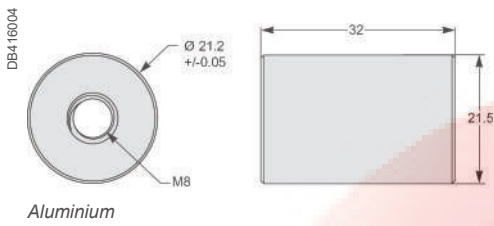

METSECT5CYL2

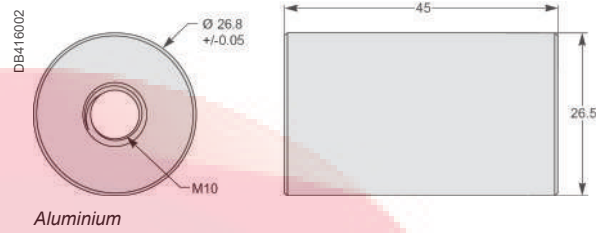

16550

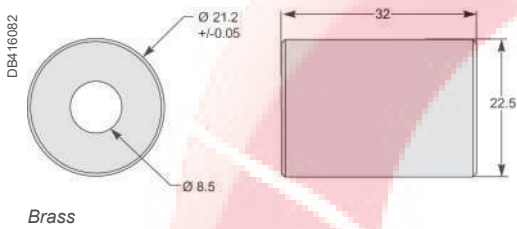

16551

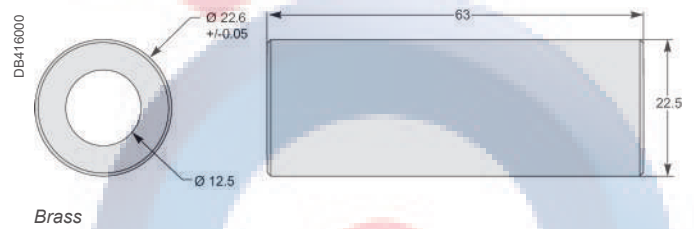

Covers

METSECT5COVER

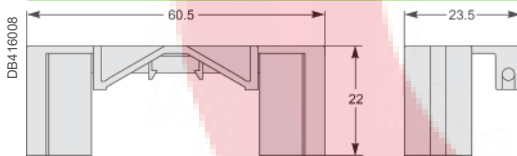

optimizer

Split core CTs

Hazard Label

⚠ DANGER

HAZARD OF ELECTRIC SHOCK, EXPLOSION, OR ARC FLASH



- Apply appropriate personal protective equipment (PPE) and follow safe electrical work practices. See NFPA 70E in the USA, CSA Z462 or applicable local standards.
- Turn off all power supplying this device and the equipment in which it is installed before working on the device or equipment.
- Always use a properly rated voltage sensing device to confirm that all power is off.
- Treat I/O wiring connected to multiple devices as hazardous live until determined otherwise.
- Do not exceed the device's ratings for maximum limits.
- Do not use this device for critical control or protection applications where human or equipment safety relies on the operation of the control circuit.
- Disconnect all the device's input and output wires before performing dielectric (hi-pot) or Megger testing.

CT DAMAGE

- Never open circuit a current transformer (CT)
- Do not open the CT case.
- Do not attempt to repair any components of the CT.

Failure to follow these instructions will result in death or serious injury.

Common characteristics	Cable CT	Bus Bar CT
Secondary current Is (A)	5 A	5 A
Maximum voltage rating Ue (V)	720 V	720 V
Frequency (Hz)	50/60 Hz	50/60 Hz
Safety factor (sf)	up to 1000 A: sf ≤ 5 greater than 1000 A: sf ≤ 10	up to 1500 A: sf ≤ 5 greater than 1500 A: sf ≤ 10
Degree of protection	IP20	IP20
Operating temperature	-5°C to +50°C relative humidity 5-85 %	-5°C to +40°C relative humidity 5-85 %
Storage temperature	-25°C to +70°C	-25°C to +70°C
Compliance with standards	IEC 61869-1 IEC 61869-2	IEC 61869-1 IEC 61869-2
Secondary connection (as per model)	by terminals for lug by tunnel terminals by screws	by terminals for lug by tunnel terminals by screws

Split core CT		
CT internal	Type H	Type G
	FFC  HA HD HG HJ HP	FFV2  GA GD GG GJ
	FFHM  HM	

optimizer

Split core CTs



PB119862

METSECT5GA●●●

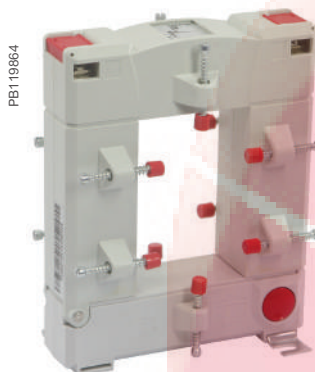

PB119864

METSECT5GD●●●

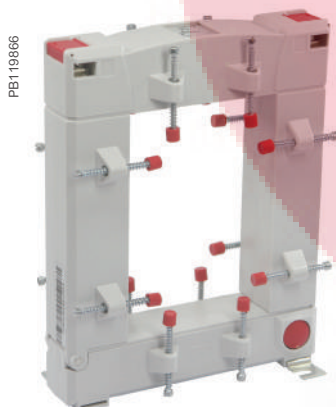

PB119866

METSECT5GG●●●



PB119868

METSECT5GJ●●●

Type G - split core current transformers (bus bar)

	Accuracy class			CT window dimension (mm)	Rating Ip/5A (A)	Commercial Reference no.	
	0.5	1	3				
GA							
	-	-	1.25	23 x 33	100	METSECT5GA010	
	-	-	1.5		150	METSECT5GA015	
	-	-	2.5		200	METSECT5GA020	
	-	1.5	-		250	METSECT5GA025	
	-	3.75	-		300	METSECT5GA030	
	1	-	-		400	METSECT5GA040	
GD							
	-	1.5	-	55 x 85	250	METSECT5GD025	
	-	2.5	-		300	METSECT5GD030	
	1	-	-		400	METSECT5GD040	
	2.5	-	-		500	METSECT5GD050	
	2.5	-	-		600	METSECT5GD060	
	2.5	-	-		750	METSECT5GD075	
	2.5	-	-		800	METSECT5GD080	
	5	-	-		1000	METSECT5GD100	
GG							
	-	1.5	-		85 x 125	250	METSECT5GG025
	-	2.5	-	300		METSECT5GG030	
	-	2.5	-	400		METSECT5GG040	
	2.5	-	-	500		METSECT5GG050	
	2.5	-	-	600		METSECT5GG060	
	2.5	-	-	750		METSECT5GG075	
	2.5	-	-	800		METSECT5GG080	
	5	-	-	1000		METSECT5GG100	
	5	-	-	1200		METSECT5GG120	
	7.5	-	-	1250		METSECT5GG125	
	7.5	-	-	1500		METSECT5GG150	
GJ							
	10	-	-	85 x 165	1000	METSECT5GJ100	
	10	-	-		1200	METSECT5GJ120	
	10	-	-		1500	METSECT5GJ150	
	10	-	-		1600	METSECT5GJ160	
	10	-	-		2000	METSECT5GJ200	
	10	-	-		2500	METSECT5GJ250	
	15	-	-		3000	METSECT5GJ300	
	15	-	-		4000	METSECT5GJ400	

See your Schneider Electric representative for complete ordering information.

optimizer

Split core CTs contd.

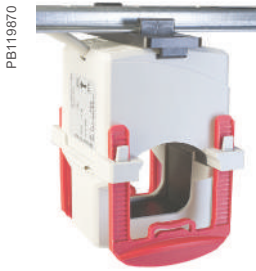

PB119870

METSECT5HA●●●

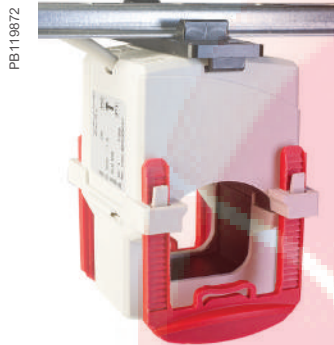

PB119872

METSECT5HD●●●

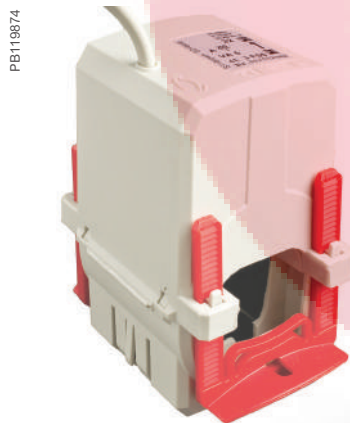

PB119874

METSECT5HG●●●

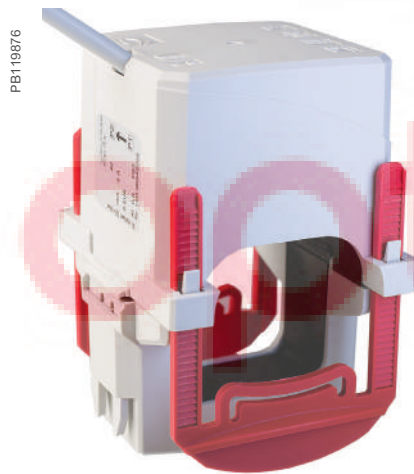

PB119876

METSECT5HJ●●●

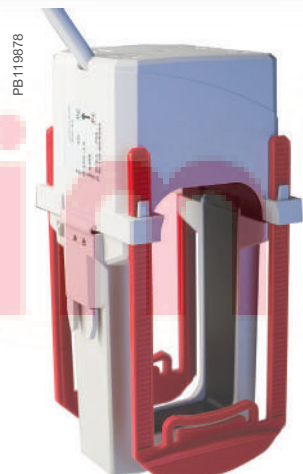

PB119878

METSECT5HM●●●

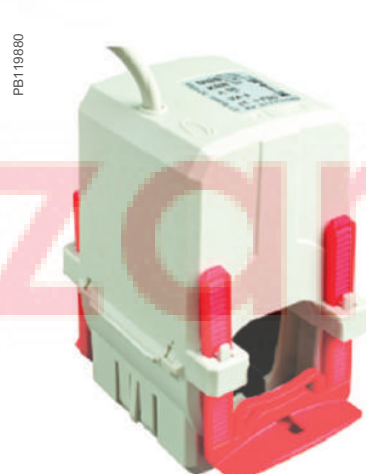

PB119880

METSECT5HP●●●

Type H - split core current transformers (cable)							
	Accuracy class			CT window dimension (mm)	Rating I _p /5A (A)	Commercial Reference no.	
	Max power (VA)						
	0.5	1	3				
HA							
	-	1	-	18.4 x 19	150	METSECT5HA015	
	-	1.5	-		150	METSECT5HA020	
	1	-	-		250	METSECT5HA025	
HD							
	-	1	-	27.9 x 27	250	METSECT5HD025	
	-	1.5	-		300	METSECT5HD030	
	-	2.5	-		400	METSECT5HD040	
	1	-	-		500	METSECT5HD050	
HG							
	-	-	1.5	Ø32.5	100	METSECT5HG010	
	-	-	2.5		125	METSECT5HG013	
	-	-	3		150	METSECT5HG015	
	-	-	3		200	METSECT5HG020	
	-	-	3		250	METSECT5HG025	
	-	2.5	-		300	METSECT5HG030	
	-	5	-		400	METSECT5HG040	
	-	5	-		500	METSECT5HG050	
	-	5	-		600	METSECT5HG060	
HJ							
	-	2.5	-	42.4 x 43	300	METSECT5HJ030	
	-	5	-		400	METSECT5HJ040	
	-	5	-		500	METSECT5HJ050	
	2.5	-	-		600	METSECT5HJ060	
	2.5	-	-		750	METSECT5HJ075	
	2.5	-	-		800	METSECT5HJ080	
HM							
	-	2.5	-	42.4 x 85	300	METSECT5HM030	
	-	5	-		400	METSECT5HM040	
	-	5	-		500	METSECT5HM050	
	2.5	-	-		600	METSECT5HM060	
	2.5	-	-		750	METSECT5HM075	
	2.5	-	-		800	METSECT5HM080	
HP							
	-	1.5	-	Ø44	250	METSECT5HP025	
	-	2.5	-		300	METSECT5HP030	
	-	5	-		400	METSECT5HP040	
	-	5	-		500	METSECT5HP050	
	-	5	-		600	METSECT5HP060	
	-	5	-		750	METSECT5HP075	
	-	5	-		800	METSECT5HP080	
	-	5	-		1000	METSECT5HP100	

See your Schneider Electric representative for complete ordering information.

Split core CT dimensions

Gx products

GA Dimensions

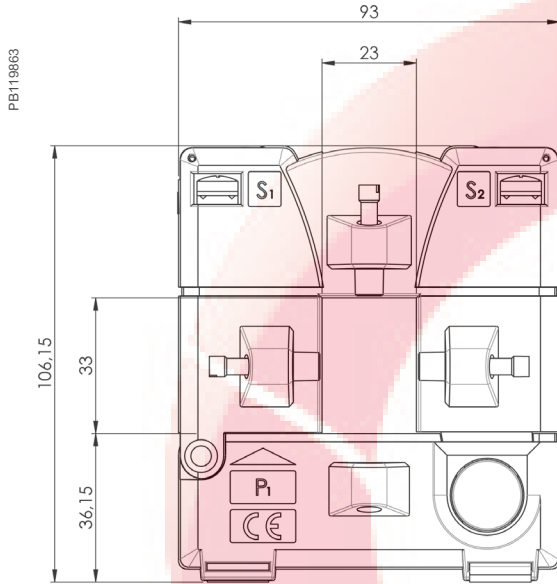

GD Dimensions

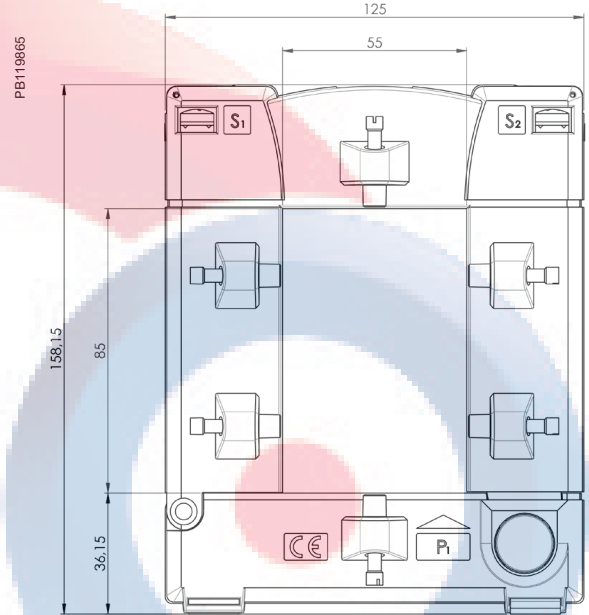

GG Dimensions

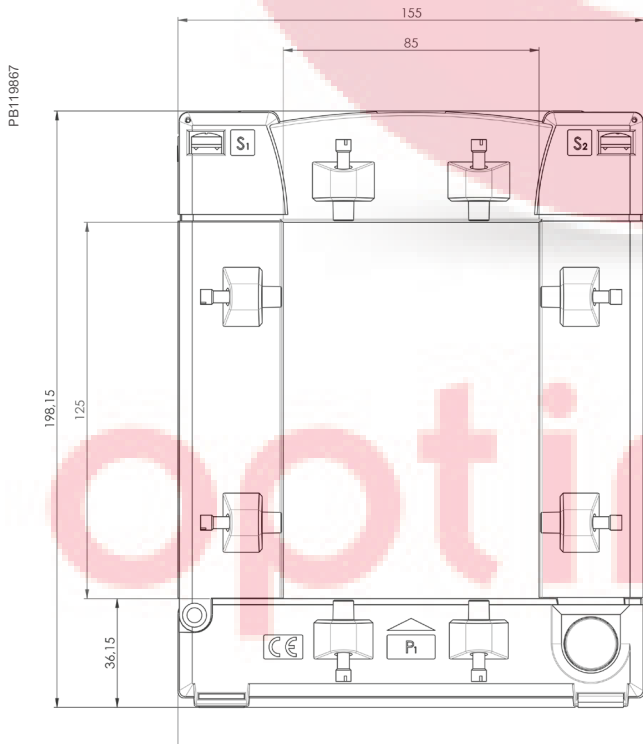

GJ Dimensions

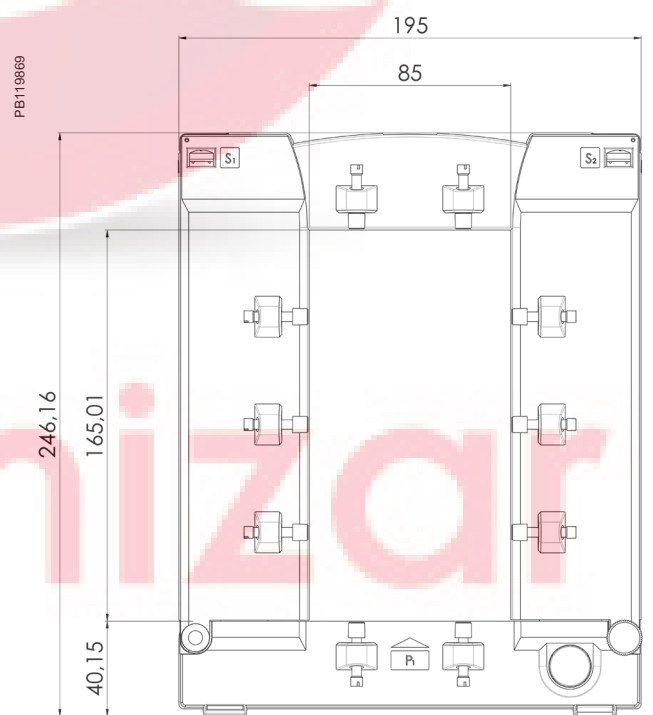

Split core CT dimensions contd.

Hx products

HA Dimensions

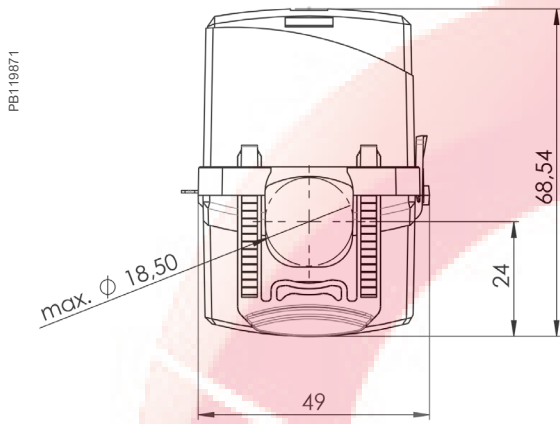

HD Dimensions

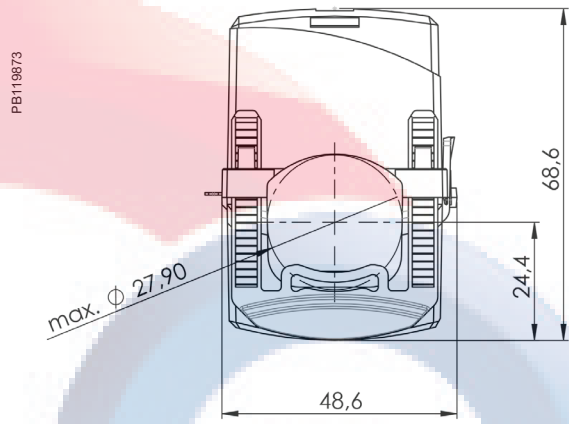

HG Dimensions

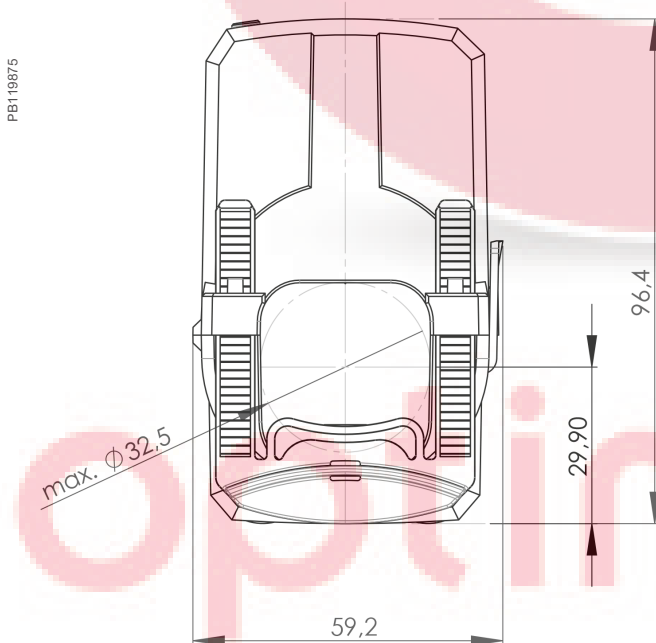

HJ Dimensions

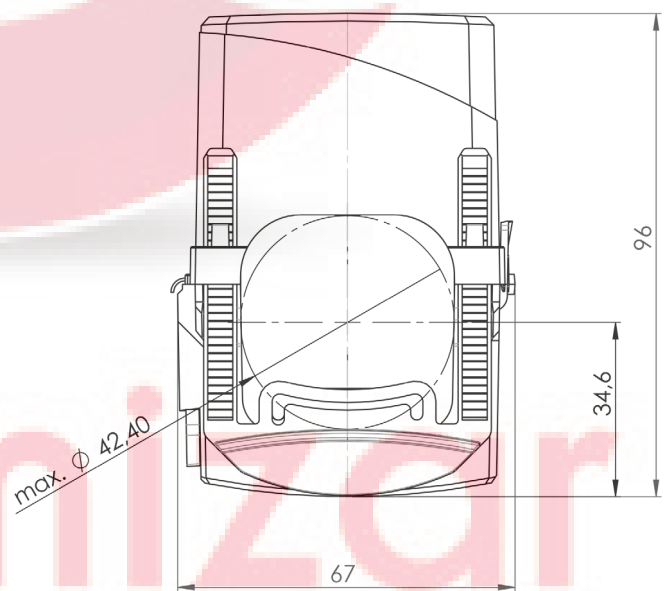

Split core CT dimensions contd.

HM Dimensions

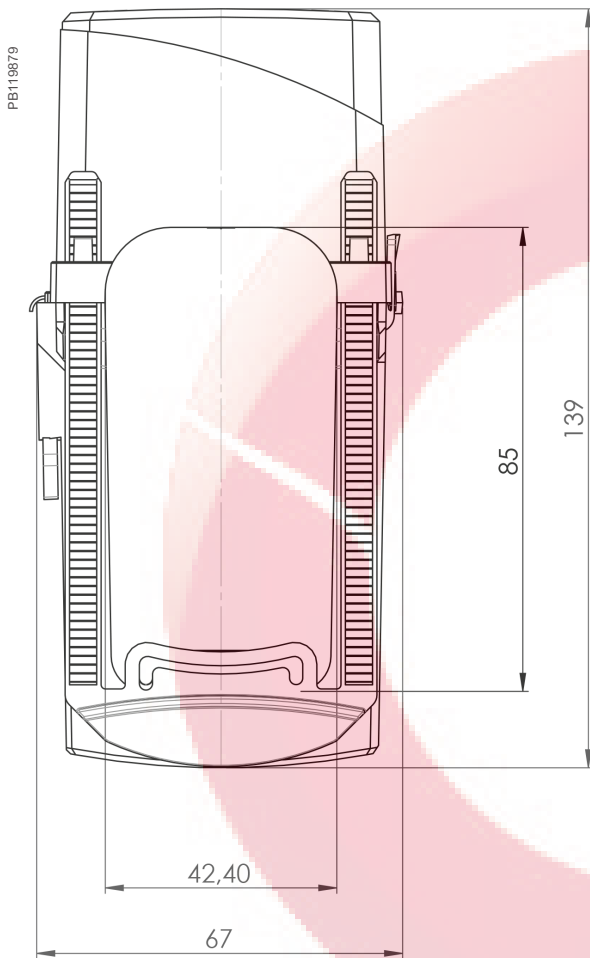

HP Dimensions

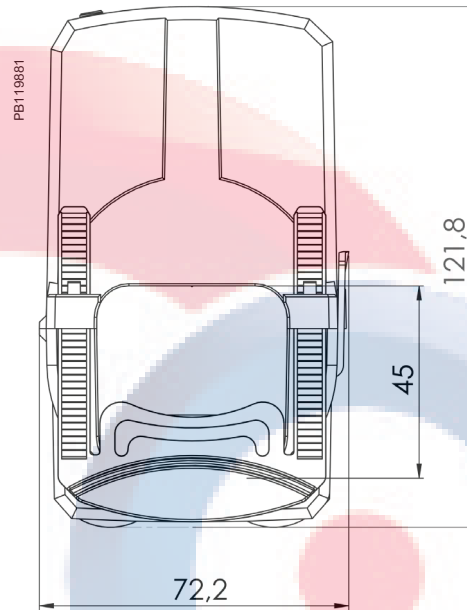

optimizer

Rogowski CTs

PB118060



METSECTR30500

PowerLogic Rogowski Current Transformer				
Main	METSECTR30500	METSECTR46500	METSECTR60500	METSECTR90500
Range	PowerLogic			
Product or component type	Current transducer			
Accessory / part category	Measurement accessory			
Range compatibility	PowerLogic EM3500 - EM3555A EM3502A EM3560 EM3550A EM3560 EM3561A PowerLogic EM4200 - EM4236 EM4235 Acti9 iEM3000 - iEM3555 iEM3565			
Current transformer type	Flexible core			
Complementary				
Electrical connection	Flying lead 2.4 m 600 V AC max. voltage L-N sensed conductor			
Cable	1000 V AC UL style 21223 cable with 22 AWG leads			
Current range	50 A to 5000 A			
Network frequency	50/60 Hz			
Measurement accuracy	±1 % from 50 A to 5000 A			
Installation category	600 V AC Cat IV			
Pollution degree	2			
Dimensions	METSECTR30500	METSECTR46500	METSECTR60500	METSECTR90500
CT core thickness	8 mm diameter	8 mm diameter	8 mm diameter	8 mm diameter
CT core length (open)	300 mm	460 mm	600 mm	900 mm
Diameter (closed)	96 mm	146 mm	191 mm	287 mm
Environment				
Standards	EN 61010-1, UL 61010-1, EN 61010-2-032, UL 61010-2-032			
Product certifications	CURus UL recognized			
Ambient air temperature for operation	-15 °C to 60 °C			
Ambient air temperature for storage	-40 °C to 70 °C			
Humidity range	0 to 95 % non-condensing			
Altitude	2000 m max			
Protection degree	IP67			
Commercial Reference Numbers				
METSECTR25500	Powerlogic - Rogowski current transformer, 250 mm CT core length, 80 mm dia. CT, rope, 600 V AC, 5 kA			
METSECTR30500	Powerlogic - Rogowski current transformer, 300 mm CT core length, 96 mm dia. CT, rope, 600 V AC, 5 kA			
METSECTR46500	Powerlogic - Rogowski current transformer, 460 mm CT core length, 146 mm dia. CT, rope, 600 V AC, 5 kA			
METSECTR60500	Powerlogic - Rogowski current transformer, 600 mm CT core length, 191 mm dia. CT, rope, 600 V AC, 5 kA			
METSECTR90500	Powerlogic - Rogowski current transformer, 900 mm CT core length, 287 mm dia. CT, rope, 600 V AC, 5 kA			

Panel instruments

Schneider Electric panel instruments reliably comply with the most stringent standards, including IEC, MID, UL, etc., and we thoroughly test all products with recognized, third-party laboratories.

Our products are simple to install, configure, and use. This saves our partners time and money and lets them deliver the best solutions in a timely and cost-effective manner.

Whatever the size or type of application, the PowerLogic™ product line is an integral part of smart panels.

PB119006
PB112024
PB101118



optimizer



16029



15202



16003



iAMP.



16029



iVLT.



16061

Function

iAMP

Ammeters measure the current flowing through an electric circuit in amps.

iVLT

Voltmeters measure the potential (voltage) difference of an electric circuit in volts.

Common technical data

- Accuracy: Class 1.5.
- Complies with standards IEC 60051-1, IEC 61010-1 and IEC 61000-4.
- Ferromagnetic device.
- Pseudo-linear scale over 90°.
- Ammeters (except catalog number 16029):
 - connection on CT, ratio $I_n/5$, to be ordered separately interchangeable dials.
- Temperature:
 - operating temperature: -25 °C to 55 °C
 - reference temperature: 23 °C
- Influence of temperature on accuracy: $\pm 0.03 \text{ \%}/^\circ\text{C}$.
- Utilisation frequency: 50 Hz to 60 Hz.
- Consumption:
 - AMP: 1.1 VA
 - VLT catalog number 15060: 2.5 VA
 - VLT catalog number 16061: 3.5 VA.
- Permanent overload:
 - AMP: 1.2 I_n
 - VLT: 1.2 U_n .
- Maximum overload for 5 s:
 - AMP: 10 I_n
 - VLT: 2 U_n .
- Connection: tunnel terminals for 1.5 to 6 mm² rigid cables.

Commercial reference numbers

Type	Scale	Connection with CT	Width in mod. of 9 mm	Comm. ref. no.
iAMP with direct connection				
	0-30 A	no	8	16029
iAMP with connection on CT				
Basic device (delivered without dial)		X/5	8	16030
Dial	0-5 A			
	0-50 A	50/5		16032
	0-75 A	75/5		16033
	0-100 A	100/5		16034
	0-150 A	150/5		16035
	0-200 A	200/5		16036
	0-250 A	250/5		16037
	0-300 A	300/5		16038
	0-400 A	400/5		16039
	0-500 A	500/5		16040
	0-600 A	600/5		16041
	0-800 A	800/5		16042
	0-1000 A	1000/5		16043
	0-1500 A	1500/5		16044
	0-2000 A	2000/5		16045
iVLT				
	0-300 V		8	16060
	0-500 V		8	16061

See your Schneider Electric representative for complete ordering information.

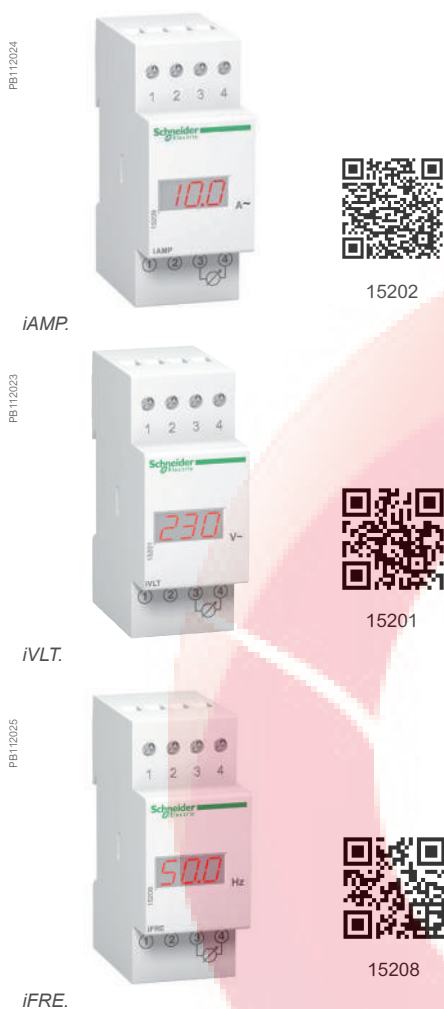

Function

iAMP

Ammeters measure in amps the current flowing through an electric circuit.

iVLT

Voltmeters measure in volts the potential (voltage) difference of an electric circuit.

iFRE

Frequency meters measure in hertz the frequency of an electric circuit from 20 to 600 V AC.

Common technical data

- Supply voltage: 230 V AC
- Operating frequency: 50 Hz to 60 Hz.
- Display by red LED: 3 digits, h = 8 mm (0.31 in).
- Accuracy at full-scale : 0.5 % ±1 digit.
- Consumption: max. 5 VA or rated 2.5 VA.
- Degree of protection:
 - IP40 on front face.
 - IP20 at terminal level.
- Connection: tunnel terminals for 2.5 mm² cables.

Specific data

10 A direct reading ammeter

- Minimum value measured: 4 % of rating.
- Measurement input consumption: 1 VA.

Multi-rating ammeter

- Ratings:
 - in direct reading: 5 A.
 - by CT (not supplied) configurable on the front face of the ammeter: 10, 15, 20, 25, 40, 50, 60, 100, 150, 200, 250, 400, 500, 600, 800, 1000, 1500, 2000, 2500, 4000, 5000 A.
- Minimum value measured: 4 % of rating.
- Measurement input consumption: 0.55 VA.

Voltmeter

- Direct measurement: 0...600 V AC
- Input impedance: 2 MW.
- Minimum value measured: 4 % of rating.

Frequency meter

- Minimum value measured: 20 Hz.
- Maximum value measured: 100 Hz.
- Full-scale display: 99.9 Hz.

Compliance with standards

- Safety: IEC/EN 61010-1.
- EMC electromagnetic compatibility: IEC/EN 65081-1 and IEC/EN 65082-2.

Commercial reference numbers

Type	Scale	Connection with CT	Width in mod. of 9 mm	Comm. ref. no.
Direct reading iAMP	0-10 A	No	4	15202
	0-5000 A	As per rating	4	15209
iVLT	0-600 V		4	15201
	20-100 Hz		4	15208

See your Schneider Electric representative for complete ordering information.

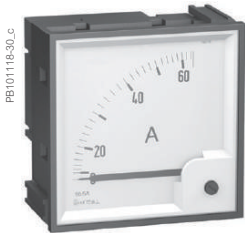

AMP for standard feeder.



16009

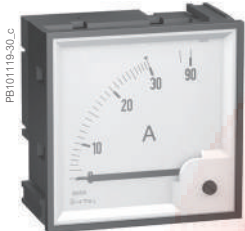

AMP for motor feeder.



16006

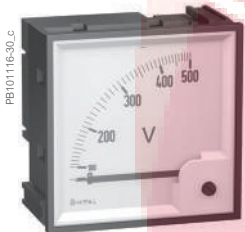

VLT.



16005

Function

The 72 x 72 measurement devices are designed for flush-mounted installation on doors, wicket doors and front plates of enclosures and cubicles.

AMP

The ammeters measure in amps the current flowing through an electrical circuit.

VLT

The voltmeter measure in volts the potential difference (voltage) of an electrical circuit.

Common technical data

- Accuracy: Class 1.5.
- Compliance with standard IEC 60051-1, IEC 61010-1 and IEC 61000-4.
- Ferromagnetic device.
- Scale length: 62 mm over 90°.
- Mounting in enclosure or in cubicle.
- Degree of protection: IP52.
- Maximum operating position: 30° / vertical.
- Temperature:
 - operation: -25 °C to 50 °C.
 - reference: 23 °C.
- Influence of temperature on accuracy: ±0.003 %/ °C.
- Utilisation frequency: 50 Hz to 60 Hz.

AMP specific technical data

- Needs a In/5 CT to be ordered separately.
- Interchangeable dials to be ordered separately.
- Consumption: 1.1 VA.
- Permanent overload: 1.2 In.
- Maximum overload for 5 s: 10 In.

VLT specific technical data

- Consumption: 3 VA.
- Permanent overload: 1.2 Un.
- Maximum overload for 5 s: 2 Un.

Commercial reference numbers

Type	Scale	Connection on CT	Comm. ref. no.
AMP for standard feeder			
Basic device (delivered without dial)		X/5	16004
1.3 In dial	0-50 A	50/5	16009
	0-100 A	100/5	16010
	0-200 A	200/5	16011
	0-400 A	400/5	16012
	0-600 A	600/5	16013
	0-1000 A	1000/5	16014
	0-1250 A	1250/5	16015
	0-1500 A	1500/5	16016
	0-2000 A	2000/5	16019
AMP for motor feeder			
Basic device (delivered without dial)		X/5	16003
3 In dial	0-30-90 A	30/5	16006
	0-75-225 A	75/5	16007
	0-200-600 A	200/5	16008
VLT			
	0-500 V		16005

See your Schneider Electric representative for complete ordering information.

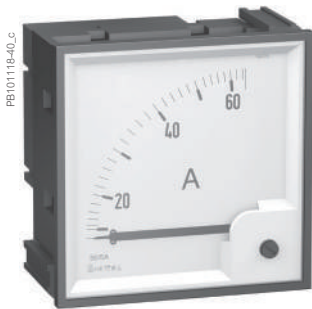

AMP for standard feeder.



16079

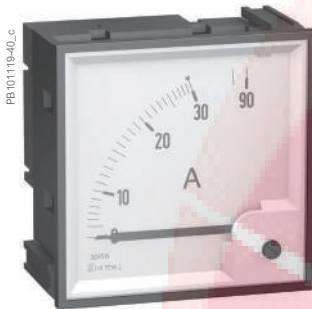

AMP for motor feeder.



16076

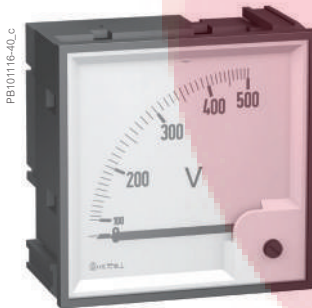

VLT.



16075

Function

The 96 x 96 measurement devices are designed for flush-mounted installation on doors, wicket doors and front plates of enclosures and cubicles.

AMP

The ammeters measure in amps the current flowing through an electrical circuit.

VLT

The voltmeter measure in volts the potential difference (voltage) of an electrical circuit.

Common technical data

- Accuracy: class 1.5.
- Compliance with standard IEC 60051-1, IEC 61010-1 and IEC 61000-4.
- Ferromagnetic device.
- Scale length: 80 mm over 90°.
- Mounting in enclosure or in cubicle.
- Degree of protection: IP52.
- Maximum operating position: 30° / vertical.
- Temperature:
 - operation: -25 °C to 50 °C.
 - reference: 23 °C.
- Influence of temperature on accuracy: ±0.003 % / °C.
- Utilisation frequency: 50 Hz to 60 Hz.

AMP specific technical data

- Needs a In/5 CT to be ordered separately.
- Interchangeable dials to be ordered separately.
- Consumption: 1.1 VA.
- Permanent overload: 1.2 In.
- Maximum overload for 5S: 10 In.

VLT specific technical data

- Consumption: 3 VA.
- Permanent overload: 1.2 Un.
- Maximum overload for 5S: 2 Un.

Commercial reference numbers

Type	Scale	Connection on CT	Comm. ref. no.
AMP for standard feeder			
Basic device (delivered without dial)		X/5	16074
1.3 In dial	0-50 A	50/5	16079
	0-100 A	100/5	16080
	0-200 A	200/5	16081
	0-400 A	400/5	16082
	0-600 A	600/5	16083
	0-1000 A	1000/5	16084
	0-1250 A	1250/5	16085
	0-1500 A	1500/5	16086
	0-2000 A	2000/5	16087
	0-2500 A	2500/5	16088
	0-3000 A	3000/5	16089
	0-4000 A	4000/5	16090
	0-5000 A	5000/5	16091
	0-6000 A	6000/5	16092
AMP for motor feeder			
Basic device (delivered without dial)		X/5	16073
3 In dial	0-30-90 A	30/5	16076
	0-75-225 A	75/5	16077
	0-200-600 A	200/5	16078
VLT			
	0-500 V		16075

See your Schneider Electric representative for complete ordering information.

Function

The 48 x 48 selector switches are designed for flush-mounted installation on doors, wicket doors and front plates of enclosures and cubicles.

CMA

The ammeter selector switch uses a single ammeter (by means of current transformers) for successive measurement of the currents of a three-phase circuit.

CMV

The voltmeter selector switch uses a single voltmeter for successive measurement of the voltages (phase-to-phase and phase-to-neutral) of a three-phase circuit.

Common technical data

- Durability:
 - electrical: 100,000 operations.
 - mechanical: 2,000,000 operations.
- AgNi contact.
- Operating temperature: -25 °C to 50 °C.
- Compliance with standards IEC/EN 60947-3.
- Degree of protection:
 - IP65 on front face.
 - IP20 at terminal level.

Commercial reference numbers

Type	Rating (A)	Voltage (V)	Number of positions	Comm. ref. no.
CMA	20		4	16017
CMV		500	7	16018

See your Schneider Electric representative for complete ordering information.

Connection

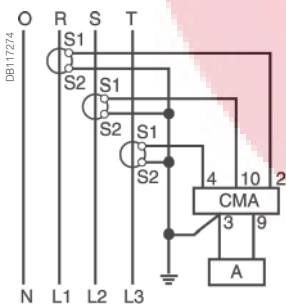

CMA.

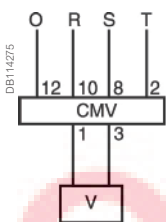

CMV.

Reading 3 phase-to-earth voltages + 3 phase-to-phase voltages.

Note: when connecting do not remove the pre-cabling.

See appropriate Installation Guide for this product.



15126

iCMA.



15125

iCMV.

Function

iCMA

This 4-position ammeter selector switch uses a single ammeter (using current transformers) for successive measurement of the currents of a three-phase circuit.

iCMV

This 7-position voltmeter selector switch uses a single voltmeter for successive measurement of voltages (phase-to-phase and phase-to-neutral) of a three-phase circuit.

Common technical data

- Rotary handle.
- Maximum operating voltage: 440 V, 50/60 Hz.
- Nominal thermal current: 10 A.
- Operating temperature: -20 °C to 55 °C.
- Storage temperature: -25°C to 80°C.
- Mechanical durability (AC21A-3 x 440 V): 2,000,000 operations.
- Degree of protection:
 - IP66 on front face.
 - IP20 at terminal level.
- Electrical durability: 1,000,000 operations.
- Connection: jumper terminals with captive screws, for cables up to 1.5 mm².
- Complies with standards: IEC/EN 60947-3.

Commercial reference numbers

Type	Rating (A)	Voltage (V AC)	Width in mod. of 9 mm	Comm. ref. no.
iCMA	10	415	4	15126
iCMV	10	415	4	15125

See your Schneider Electric representative for complete ordering information.

Connection

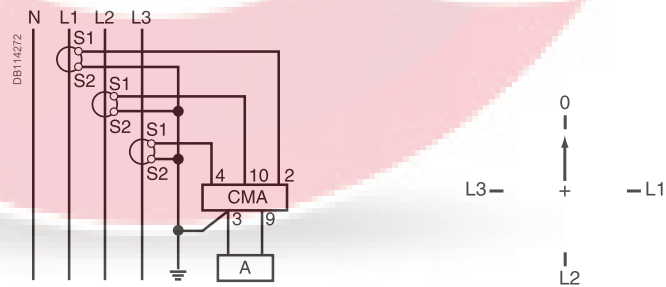

iCMA.



iCMV.

See appropriate Installation Guide for this



iCH "DIN".



15440

Function

Electromechanical counter that counts the operating hours of a machine or piece of electrical equipment. Giving a precise indication of operating time, the counter is used to decide when to carry out preventive maintenance.

Common technical data

- Electromechanical display.
- Maximum display: 99999.99 hours.
- Display accuracy: 0.01 %.
- Without reset.
- Storage temperature: -25 °C to 85 °C.
- Connection: tunnel terminals for 2.5 mm² cable.

Specific technical data

iCH "DIN"

- Consumption: 0.15 VA.
- Operating temperature: -10 °C to 70 °C.
- Mounting on DIN rail.

CH "48 x 48"

- Consumption:
 - 15607: 0.25 VA
 - 15608: 0.15 VA
 - 15609: 0.02 VA to 12 V and 0.3 VA to 36 V.
- Operating temperature: -20 °C to 70 °C.
- Degree of protection: IP65 on front face.
- Mounting on front face of monitoring switchboards.

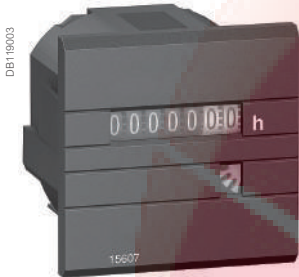

CH "48 x 48".



15607

Commercial reference numbers

Type	Voltage (V)	Width in mod. of 9 mm	Comm. ref. no.
iCH "DIN"	230 V AC ± 10 %/50 Hz	4	15440
CH "48 x 48"	24 V AC ± 10 %/50 Hz		15607
	230 V AC ± 10 %/50 Hz		15608
	12 to 36 V DC		15609

See your Schneider Electric representative for complete ordering information.

Connection

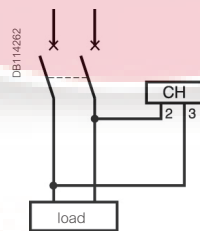

iCH "DIN".

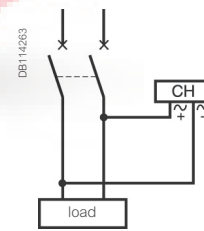

CH "48 x 48".

See appropriate Installation Guide for this

optimizer

iCI legs



15443

iCI impulse counter

Function

Electromechanical counter designed to count impulses emitted by: kilowatt-hour meters, temperature overrun detectors, people meters, speed meters, etc.

Common technical data

- Supply and metering voltage: 230 V AC \pm 10 %, 50/60 Hz.
- Consumption: 0.15 VA.
- Maximum display: 9 999 999 impulses.
- Without reset.
- Metering data:
 - minimum impulse time: 50 ms
 - minimum time between 2 impulses: 50 ms.
- Storage temperature: -25 °C to 85 °C.
- Operating temperature: -10 °C to 70 °C.
- Connection: tunnel terminals for 2.5 mm² cable.

Commercial reference numbers

Type	Width in mod. of 9 mm	Comm. ref. no.
iCI	4	15443

Connection

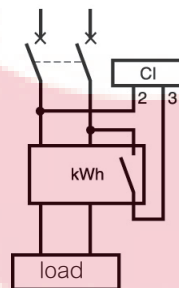
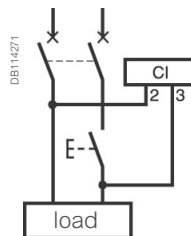

See appropriate Installation Guide for this

optimizer

Analog ammeters and voltmeters iAMP, iVLT

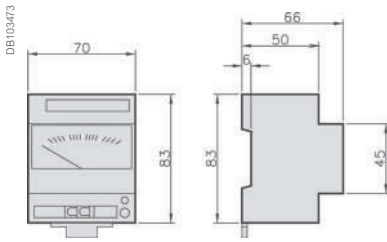

Digital ammeters, voltmeter and frequency meter iAMP, iVLT

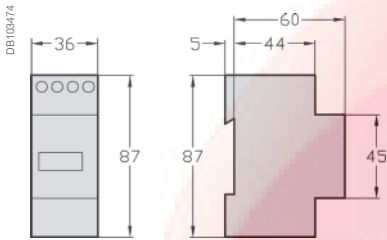

iCMA and iCMV selector switches

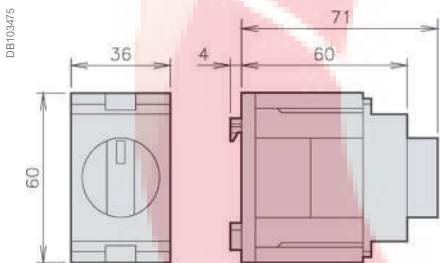

72 x 72 analog ammeters and voltmeter

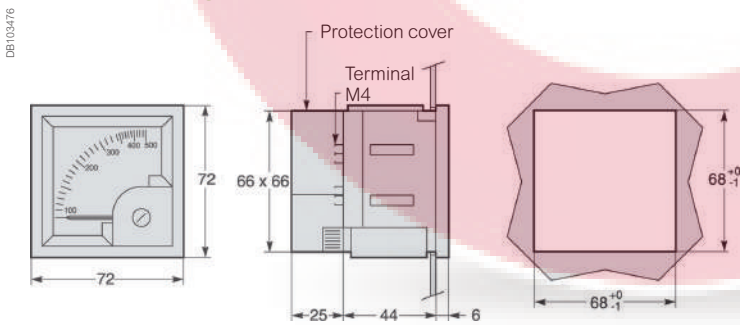

96 x 96 analog ammeters and voltmeter

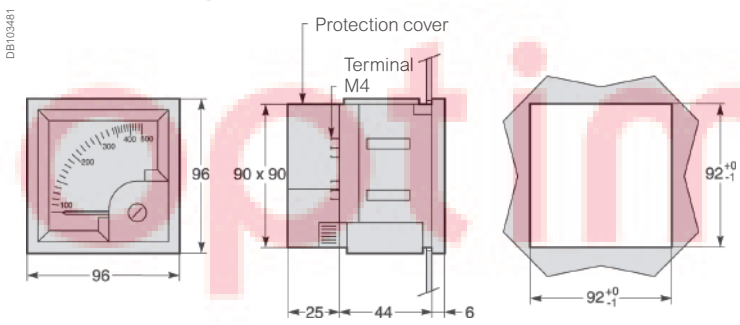

See the appropriate Installation Guide for this product.

48 x 48 CMA and CMV selector switches

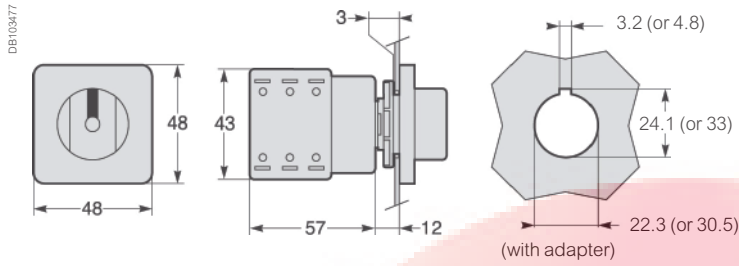

iCI impulse counter and iCH hour counter

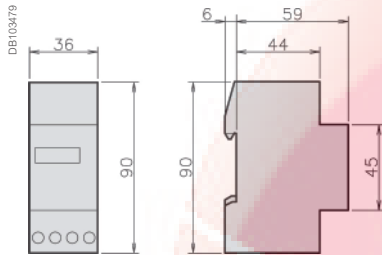

48 x 48 CH hour counters

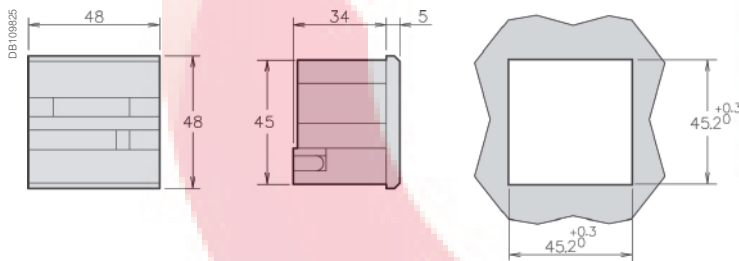

See the appropriate Installation Guide for this product.

optimizer

Basic energy metering

Whether you require a single-phase kWh meters or full-featured, dual tariff energy meter, Schneider Electric provides iEM2xxx & iEM3xxx series meters to best fit your customer's application.

- PowerLogic iEM2000 series
- PowerLogic iEM2100 series
- PowerLogic iEM3000 series

PB108410
PB115001
PB108410



optimizer



A9MEM2000



A9MEM2100



A9MEM3100

Acti9 iEM2000 Series

Technical Datasheet

The Acti9 iEM2000 series energy meters offer a cost-attractive, competitive range of single-phase DIN rail-mounted energy meters ideal for sub-billing and cost allocation applications.

Applications

- Monitor power consumption for each floor, office sector, or unit
- Allocate energy costs to lower cost of operations, optimise your building's power efficiency
- Connect to power management software to take full advantage of the IoT digital power installation

PB105289



A9MEM2000

The solution for:

All markets that can benefit from a solution that includes PowerLogic iEM2000 series meters:

- Buildings
- Industry
- Data Centre & networks
- Infrastructures (airport, road tunnels, telecom).

Benefits

The Acti9 iEM2000 series meters are economical and easy to install in panelboards and switchboards:

- DIN rail mounted, compact size
- Accurate data measurement with Class 1 accuracy

Advantages

- Active energy Class 1 accuracy, with LCD display
- Modbus RS-485 and pulse output
- Direct connect, self-powered
- MID approved
- Two tariffs

Energy management system:

To get the most effective use from your Schneider Electric measurement and metering devices, we offer a range of dedicated data loggers and gateways for your building energy management.

Conformity of standards

- IEC 62053-21
- EN 50470-3

iEM2000 feature selection

	iEM2000T	iEM2000	iEM2010	iEM2050	iEM2055
Self-powered	■	■	■	■	■
Display		■	■	■ (6 digit LCD)	■ (6 digit LCD)
Width (mm)	18	18	18	17.5	17.5
Current input	40 A	40 A	40 A	45 A	45 A
Multi-tariff				2 tariffs	2 tariffs
Communication				Modbus	Modbus
Active Energy accuracy	Class 1 IEC 62053-21	Class 1 IEC 62053-21 Class B EN 50470-3	Class 1 IEC 62053-21 Class B EN 50470-3	Class 1 IEC 62053-21	Class 1 IEC 62053-21 Class B EN 50470-3
Digital outputs	1 P/O		1 P/O	1 P/O	1 P/O
MID for billing application		■	■		■
Commercial reference number	A9MEM2000T	A9MEM2000	A9MEM2010	A9MEM2050	A9MEM2055

See your Schneider Electric representative for complete ordering information.

iEM2000 series technical specifications

Technical specifications

	iEM2000T	iEM2000	iEM2010	iEM2050	iEM2055
COMM reference number	A9MEM2000T	A9MEM2000	A9MEM2010	A9MEM2050	A9MEM2055
Direct connection	Up to 40 A	Up to 40 A	Up to 40 A	Up to 45 A	Up to 45 A
Pulse output operation	100 pulses/kwh (120ms long)			10000, 2000, 1000, 100, 10, 1, 0.1, 0.01 pulses/kWh	
Display capacity	999999.9 kWh			9999.99 kWh (switching to 99999.9 when over this value)	
Voltage range (L-N)	184 to 276 V AC			195 to 253 V AC	
Operating frequency	50/60 Hz			50 Hz	
Meter constant LED	3200 flashes per KWh			10000 flashes per KWh	
Wiring capacity (Power)	4 mm ²			2.5 mm ²	
Wiring capacity (Communications)	10 mm ²			8-10 mm ²	
Consumption				<10 VA	
IP protection	IP40 front panel and IP20 casing			IP51 front panel	
Temperature	-10°C to 55°C			-25°C to 55°C	
Active energy	■	■	■	■	■
Reactive energy				■	■
Active power				■	■
Reactive power				■	■
Power Factor				■	■
Current and voltage				■	■
Frequency				■	■

iEM2050/iEM2055 dimensions

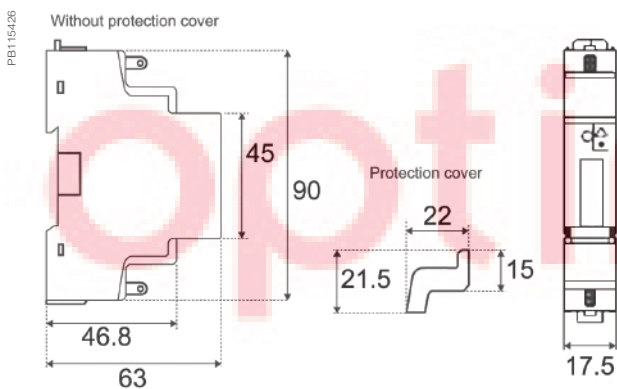

Maximum diameter power connection clamps 8 mm² (solid copper). See the appropriate product Installation Guide for complete instructions.

iEM2000 dimensions

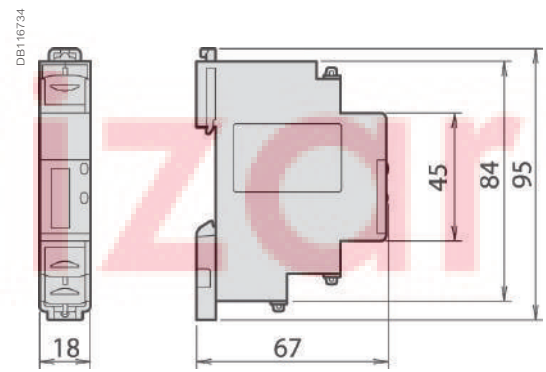

Maximum diameter power connection clamps 8 mm² (solid copper). See the appropriate product Installation Guide for complete instructions.

Acti9 iEM2100 Series

The Acti9 iEM2100 series energy meters are ideal for basic kWh metering and billing applications and support two protocols (Modbus and M-bus) that allow them to integrate seamlessly into your customers' existing networks.

Applications

- Monitor the power consumption of each sector, unit, workshop...
- Manage an electrical installation and optimise your building's power efficiency
- Various business, industrial and residential applications

PE119059

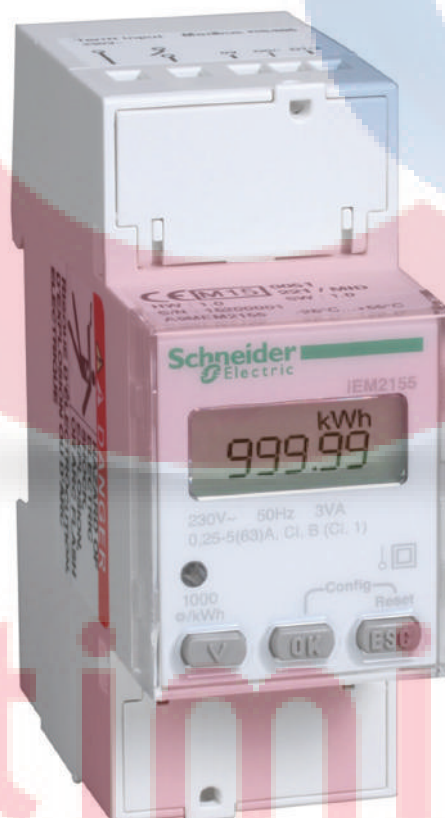

A9MEM2100

The solution for

All markets that can benefit from a solution that includes PowerLogic iEM2100 series meters:

- Buildings
- Industry
- Data Centre & networks
- Infrastructures (airport, road tunnels, telecom).

Benefits

The Acti9 iME kilowatt-hour meters are specially economic and easy to install in all switchboards.

Competitive advantages

- Compact size
- MID compliant (selected models) providing certified accuracy and data security
- Four quadrant measurement
- Electrical parameter measurement eg. V, I, P, PF
- Onboard Modbus or M-bus communication
- A complete range of energy meters
- Compatible with Acti9 range

Energy management system:

To get the most effective use from your Schneider Electric measurement and metering devices, we offer a range of dedicated data loggers and gateways for your building energy management.

Conformity of standards

- IEC 62052-11
- IEC 62053-21
- IEC 62053-23
- EN 50470-1
- EN 50470-3

iEM2100 feature selection

	iEM2100	iEM2105	iEM2110	iEM2135	iEM2150	iEM2155
Self-powered	■	■	■	■	■	■
Display	■	■	■	■	■	■
Width (mm)	36	36	36	36	36	36
Current input	63 A	63 A	63 A	63 A	63 A	63 A
Active Energy accuracy	Class 1	Class 1	Class 1	Class 1	Class 1	Class 1
Reactive Energy accuracy	Class 2	Class 2	Class 2	Class 2	Class 2	Class 2
Four quadrant Energy measurement			■	■	■	■
Multi-tariff			2	2		2
Digital inputs			1 (tariff switching)	1 (tariff switching)		1 (tariff switching)
Digital outputs		1 P/O	2 P/O's			
Communication protocol				M-bus	Modbus RS-485	Modbus RS-485
MID for billing application			■	■		■
Commercial reference number	A9MEM2100	A9MEM2105	A9MEM2110	A9MEM2135	A9MEM2150	A9MEM2155

Acti9 iEM2100 series technical specifications

Technical specifications						
	iEM2100	iEM2105	iEM2110	iEM2135	iEM2150	iEM2155
Direct connection	63 A	63 A	63 A	63 A	63 A	63 A
Pulse output operation		1 pulse/kwh (200ms long)	1 to 1000 pulses / kwh or kvarh (30 to 100ms long)			
Display capacity	99999 KWh or 999.99 MWh			999999.99KWh		
Voltage range (L-N)	184 to 276 V AC			92 to 276 V AC		
Operating frequency	50/60 Hz					
Meter constant LED	1000 flashes per KWh					
Wiring capacity (Top)	6 mm ²			4 mm ²		
Wiring capacity (Bottom)	32 mm ² (16 mm ² iEM2100/iEM2105)					
Consumption	2.5 VA			3 VA		
IP protection	IP40 front panel and IP20 casing					
Temperature	-25°C to 55°C					
Active energy	■	■	■	■	■	■
Reactive energy			■	■	■	■
Active power			■	■	■	■
Reactive power			■	■	■	■
Power Factor			■	■	■	■
Current and voltage			■	■	■	■
Frequency			■	■	■	■

iEM2100/iEM2105 dimensions

iEM2110/iEM2135/iEM2150/iEM2155 dimensions

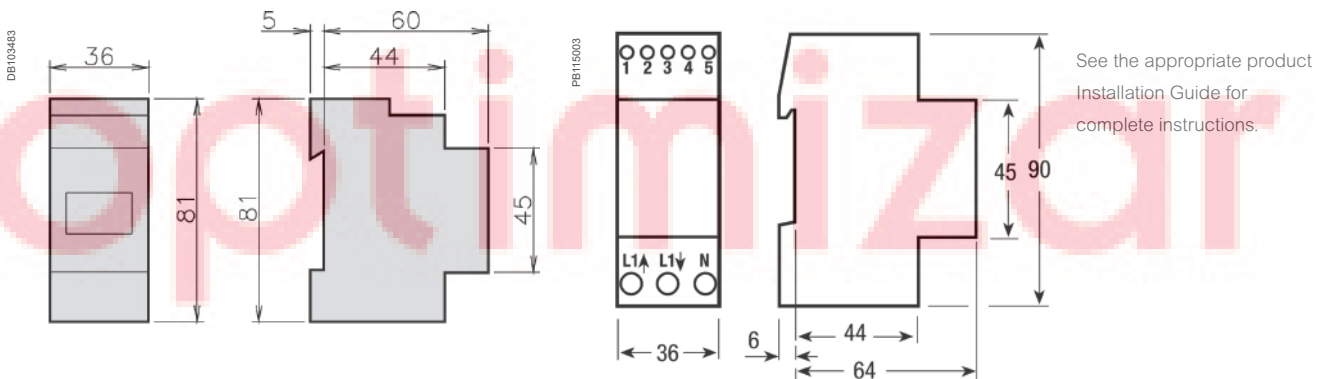

iEM2000 and iEM2100 series commercial reference numbers

Comm. reference number	Product
A9MEM2000T	iEM2000T basic energy meter, no display
A9MEM2000	iEM2000 basic energy meter
A9MEM2010	iEM2010 energy meter, kWh pulse output
A9MEM2100	iEM2100 basic energy meter
A9MEM2050	iEM2050 modular single phase power meter 230 V - 45 A with Modbus
A9MEM2055	iEM2055 modular single phase power meter 230 V - 45 A with Modbus, MID
A9MEM2105	iEM2105 energy meter, kWh pulse output with partial meter
A9MEM2110	iEM2110 energy meter, kWh and kvarh pulse outputs with two tariffs, four quadrant energy measurement, MID certified
A9MEM2135	iEM2135 energy meter, M-Bus communication, four quadrant energy measurement, two tariffs, MID certified
A9MEM2150	iEM2150 energy meter, Modbus communication, four quadrant energy measurement
A9MEM2155	iEM2155 energy meter, Modbus communication, four quadrant energy measurement, two tariffs, MID certified

See your Schneider Electric representative for complete ordering information.



optimizer

Acti9 iEM3000 Series

The Acti9 iEM3000 series energy meters is a cost-attractive, feature-rich energy metering offer for DIN rail, modular enclosures. With Modbus, BACnet, M-bus and LON protocol support, you can easily integrate these meters into commercial and non-critical buildings to add simple energy management applications to any BMS, AMR or EMS system.

Applications

Cost management applications

- Bill checking to verify that you are only charged for the energy you use
- Sub-billing individual tenants for their energy consumption, including WAGES
- Aggregation of energy consumption, including WAGES, and allocating costs per area, per usage, per shift, or per time within the same facility

Network management applications

- Basic metering of electrical parameters to better understand the behaviour of your electrical distribution system



A9MEM3100

PB108418

More than just kWh meters, the Acti9 iEM3000 series meters provide a full view of both energy consumption and on-site generation with full four-quadrant measurement of active and reactive energy delivered and received. Additionally, extensive real-time measurements (V, I, P, PF) give customers greater detail on their energy usage, and multiple tariffs give customers the flexibility to match the billing structure of their utility.

The solution for

All markets that can benefit from a solution that includes PowerLogic iEM3000 series meters:

- Buildings & industry
- Data centres and networks
- Infrastructure (airports, road tunnels, telecom)

Benefits

Optimise your energy consumption & enable energy efficiency practices

- Collect and analyse energy consumption data from each area for each type of load or circuit
- Gain an accurate understanding of business expenses by allocating the energy-related costs
- Use information to implement actions designed to reduce energy consumption

Monitor the energy consumption of your tenants or customers and establish accurate invoices

- Drive energy-efficient behaviour
- Allow building owners to bill tenants for individual measured utility usage
- Give accurate and achievable objectives for energy savings

Competitive advantages

- Compact size
- MID compliant (selected models) providing certified accuracy and data security
- Programmable digital inputs/outputs
- Multi-tariff capability
- Onboard Modbus, LON, M-bus or BACnet communication
- A complete range of energy meters
- Compatible with Acti9 range

Energy management system:

To get the most effective use from your Schneider Electric measurement and metering devices, we offer a range of dedicated data loggers and gateways for your building energy management.

Conformity of standards

- | | |
|-------------------|--------------|
| • IEC 61557-12 | • EN 50470-3 |
| • IEC 62053-21/22 | • EN 50470-1 |
| • IEC 62053-23 | • IEC 61036 |
| | • IEC 61010 |

optimizer

Acti9 iEM3000 Series

iEM3000 feature selection

	iEM3100 iEM3200 iEM3300	iEM3110 iEM3210 iEM3310	iEM3115 iEM3215	iEM3150 iEM3250 iEM3350	iEM3135 iEM3235 iEM3335	iEM3155 iEM3255 iEM3355	iEM3165 iEM3265 iEM3365	iEM3175 iEM3275 iEM3375
Self-powered	■	■	■	■	■	■	■	■
Width (18mm module)	5/5/7	5/5/7	5/5	5/5/7	5/5/7	5/5/7	5/5/7	5/5/7
Direct measurement (up to)	63 A/-/125 A	63 A/-/125 A	63 A/-	63 A/-/125 A	63 A/-/125 A	63 A/-/125 A	63 A/-/125 A	63 A/-/125 A
Measurement input through CTs (1A, 5A)	- / ■ / -	- / ■ / -	- / ■	- / ■ / -	- / ■ / -	- / ■ / -	- / ■ / -	- / ■ / -
Measurement input through VTs				- / ■ / -	- / ■ / -	- / ■ / -	- / ■ / -	- / ■ / -
Active Energy measurements class	1/0.5S/1	1/0.5S/1	1/0.5S	1/0.5S/1	1/0.5S/1	1/0.5S/1	1/0.5S/1	1/0.5S/1
Four Quadrant Energy measurement					■	■	■	■
Electrical parameter measurements (I, V, P,...)				■	■	■	■	■
Multi-tariff (internal clock)			4		4	4	4	4
Multi-tariff (external control)			4		2	2	2	2
Measurement display (no. of line)	3	3	3	3	3	3	3	3
Digital inputs	Programmable (Tariff control or WAGES input)				1	1	1	1
	Tariff control only		2					
Digital outputs	Programmable (Kwh pulse or KW overload alarm)				1	1	1	
	Kwh pulse only		1					
Communication protocols	M-bus				■			
	Modbus			■		■		
	BACnet						■	
	Lon							■
MID (legal metrology certification)		■	■		■	■	■	■
Commercial reference numbers	A9MEM3100	A9MEM3110	A9MEM3115	A9MEM3150	A9MEM3135	A9MEM3155	A9MEM3165	A9MEM3175
	A9MEM3200	A9MEM3210	A9MEM3215	A9MEM3250	A9MEM3235	A9MEM3255	A9MEM3265	A9MEM3275
	A9MEM3300	A9MEM3310		A9MEM3350	A9MEM3335	A9MEM3355	A9MEM3365	A9MEM3375

See your Schneider Electric representative for complete ordering information.

How to read table: If a cell contains a single value, that value applies to all meter models identified in the header cell(s). For cells with multiple values, the values correspond from left to right with the meter models listed from top to bottom for each associated header cell. For example, a cell with "A / B / C" means A for iEM31xx models, B for iEM32xx models, and C for iEM33xx models

Acti9 iEM3000 Series

EM3400/iEM3500 technical specifications

	iEM3455	iEM3465	iEM33555	iEM3565
Max current	0.333V-1.0V LVCTs	0.333V-1.0V LVCTs	Rogowski coils	Rogowski coils
Meter constant LED	5000/kWh			
Pulse output frequency	Up to 500p/kWh			
Multi-tariff	4 tariffs			
Communication	Modbus	BACnet	Modbus	BACnet
DI/DO	1/1			
Network	1P+N, 3P, 3P+N support LVCTs, Rogowski coils, and VTs			
Wiring capacity	6 mm ² for currents and 4 mm ² for voltages			
Display max	LCD 99999999.9kWh or 99999999.9MWh			
Voltage (L-L)	3 x 100/173 V AC to 3 x 277/480 V AC (50/60 Hz)			
IP protection	IP40 front panel and IP20 casing			
Temperature	-25°C to 70°C (K55)			
Product size	5 steps of 18 mm			
Overvoltage & measurement	Category III, Degree of pollution 2			
kWh	■			
kVARh	■			
Active power	■			
Reactive power	■			
Currents & voltages	■			
Overload alarm	■			
Hour counter	■			

See your Schneider Electric representative for complete ordering information.

optimizer

Acti9 iEM3100/iEM3300 series technical specifications

Technical specifications								
	iEM3100 iEM3300	iEM3110 iEM3310	iEM3115	iEM3150 iEM3350	iEM3135 iEM3335	iEM3155 iEM3355	iEM3165 iEM3365	iEM3175 iEM3375
Max current (direct connection)	63 A for iEM3100 models, 125 A for iEM3300 models							
Meter constant LED	500/kWh							
Pulse output	Up to 1000 p/kWh			Up to 1000 p/kWh		Up to 1000 p/kWh		
Multi-tariff			4 tariffs	4 tariffs		4 tariffs		
Communication				Modbus	Modbus	Modbus	BACnet	LON
DI/DO	0/1		2/0		1/1	1/1	1/1	1/0
MID (EN50470-3)	■				■	■	■	■
Network	1P+N, 3P, 3P+N							
Accuracy class	Class 1 (IEC 62053-21 and IEC 61557-12) Class B (EN 50470-3)							
Wiring capacity	16 mm ² for iEM3100 models, 50 mm ² for iEM3300 models							
Display max.	LCD 99999999.9kWh							
Voltage (L-L)	3 x 100/173 V AC to 3 x 277/480 V AC (50/60 Hz)							
IP protection	IP40 front panel and IP20 casing							
Temperature	-25°C to 55°C (K55)							
Product size	5 x 18 mm for iEM3100 models, 7 x 18 mm for iEM3300 models							
Overvoltage and measurement	Category III, Degree of pollution 2							
kWh	■	■	■	■	■	■	■	■
kVARh					■	■	■	■
Active power				■	■	■	■	■
Reactive power					■	■	■	■
Currents and voltages				■	■	■	■	■
Overload alarm					■	■	■	■
Hour counter					■	■	■	■



Acti9 IEM3200 series technical specifications

Technical specifications								
	iEM3200	iEM3210	iEM3215	iEM3250	iEM3235	iEM3255	iEM3265	iEM3275
Max current (1A/5A CT connected)	6 A							
Meter constant LED	5000/kWh							
Pulse output frequency		Up to 500p/kWh			Up to 500p/kWh		Up to 500p/kWh	
Multi-tariff		4 tariff			4 tariffs		4 tariffs	
Communication				Modbus	Modbus	Modbus	BACnet	LON
DI/DO		0/1	2/0		1/1	1/1	1/1	1/0
MID (EN50470-3) ⁽¹⁾		■	■		■	■	■	■
Network	1P+N, 3P, 3P+N support CTs				1P+N, 3P, 3P+N support CTs & VTs			
Accuracy class	Class 0.5S (IEC 62053-22 and IEC61557-12) Class C (EN50470-3) ⁽¹⁾							
Wiring capacity	6 mm ² for currents and 4 mm ² for voltages							
Display max.	LCD 99999999.9kWh or 99999999.9MWh							
Voltage (L-L)	3 x 100/173 V AC to 3 x 277/480 V AC (50/60 Hz)							
IP protection	IP40 front panel and IP20 casing							
Temperature	-25°C to 55°C (K55)							
Product size	5 steps of 18 mm							
Overvoltage & measurement	Category III, Degree of pollution 2							
kWh	■	■	■	■	■	■	■	■
kVARh					■	■	■	■
Active power				■	■	■	■	■
Reactive power					■	■	■	■
Currents and voltages				■	■	■	■	■
Overload alarm					■	■	■	■
Hour counter					■	■	■	■

⁽¹⁾ Only for iEM32xx used with 5 A CTs.



iEM3000/iEM3200 series dimensions

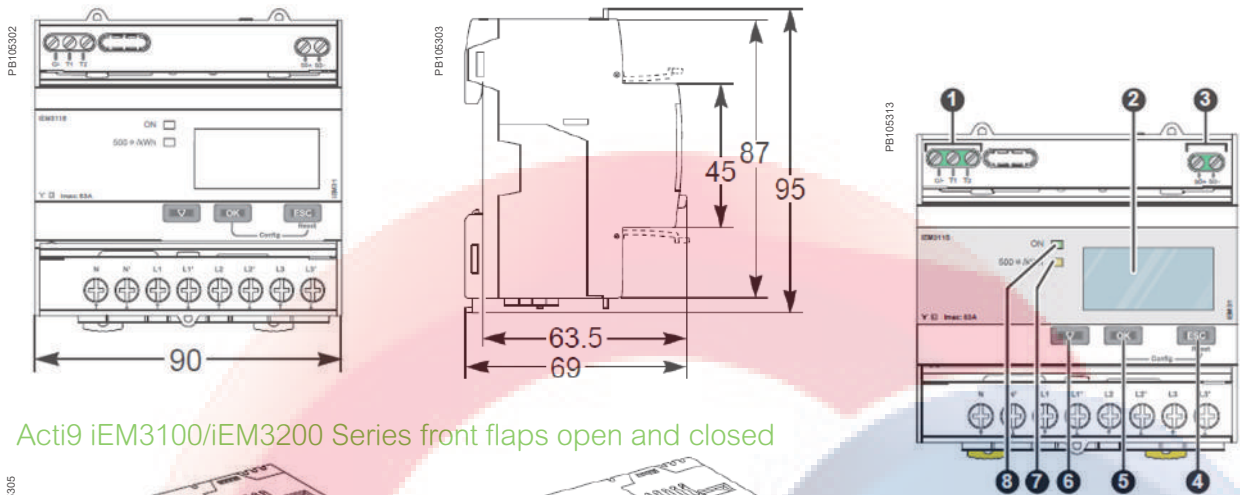

Acti9 iEM3100/iEM3200 Series front flaps open and closed

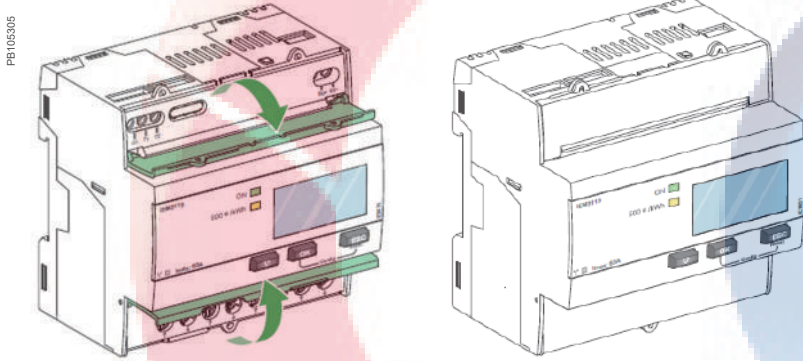

- Acti9 iEM3000 Series parts
1. Digital inputs for tariff control (iEM3115 / iEM3215)
 2. Display for measurement and configuration
 3. Pulse out for remote transfer (iEM3110 / iEM3210)
 4. ESC Cancellation
 5. OK Confirmation
 6. Selection
 7. Flashing yellow meter indicator to check accuracy
 8. Green indicator: on/off, error

iEM3300 series dimensions

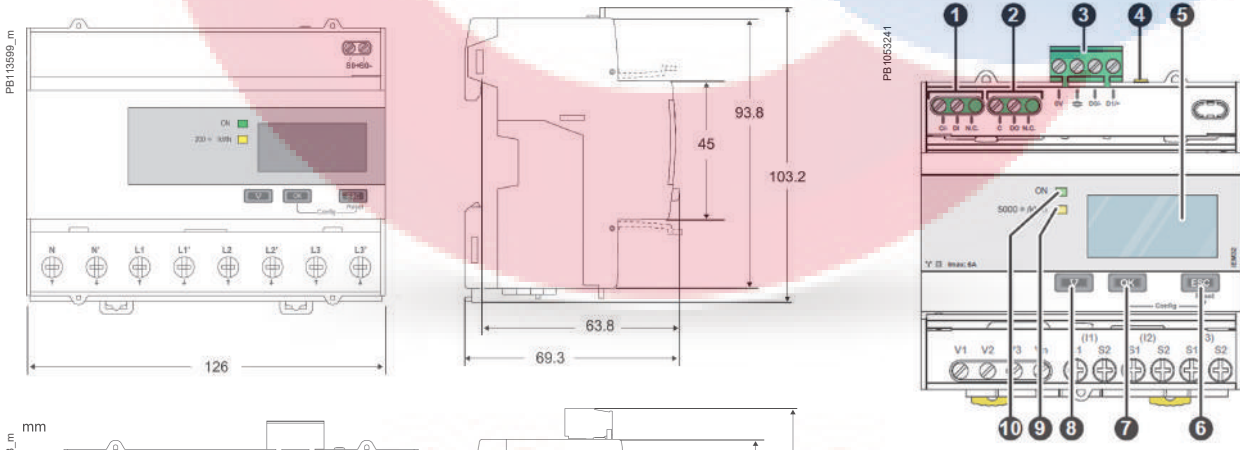

- Acti9 iEM3000 Series parts
1. Digital inputs for tariff control (iEM3115 / iEM3215)
 2. Display for measurement and configuration
 3. Pulse out for remote transfer (iEM3110 / iEM3210)
 4. ESC Cancellation
 5. OK Confirmation
 6. Selection
 7. Flashing yellow meter indicator to check accuracy
 8. Green indicator: on/off, error

Please see the appropriate **Installation Guide** for accurate and complete information on the installation of this product.

Basic multi-function metering

A range of meters designed for cost management and simple network management. Affordable to buy and easy to choose, the highly-capable PowerLogic PM5000 series meters are designed to provide the best combination of features to match all your energy cost management needs.

As well as pin-point energy savings, optimal equipment efficiency and utilisation, basic multi-function meters perform a high level assessment of the power quality in an electrical network.

- PowerLogic ION6200
- PowerLogic PM3000
- PowerLogic PM5350
- PowerLogic PM5000



PB117510
PB117510
PB108447
PB111770



M6200



A9MEM2000



A9MEM2000



A9MEM2000

ION6200 series

The PowerLogic ION6200 is a multi-function, cost-attractive, feature-rich flush or DIN rail-mounted multi-function meter that offers all the measurement capabilities required to monitor an electrical installation.

Complete with four-quadrant power, demand, energy, power factor, and frequency measurements, this versatile unit is easy to wire and mount. It offers an excellent upgrade path that lets you start with a low-cost base model and add enhanced functionality over the long term.

Applications

Cost management applications

- Basic metering
- Class 0.5S metering and sub-metering
- Replace multiple analog meters
- Cost allocation
- Substation monitoring



M6200

PE86127

The solution for

All markets that can benefit from a solution that includes PowerLogic ION6200 series meters:

- Buildings
- Industry
- Data centres and networks
- Infrastructure (e.g. airports, road tunnels, telecom)

Benefits

Optimise your energy consumption & enable energy efficiency practices

- Collect and analyse energy consumption data from each area for each type of load or circuit
- Gain an accurate understanding of business expenses by allocating the energy-related costs
- Identify savings opportunities
- Use information to implement actions designed to reduce energy consumption

Competitive advantages

Connectivity advantages

- High visibility front display panel
- Megawatt option for all power and energy values
- Complete communications - optional RS-485 port, standard Modbus RTU, data rates 1200-19200 baud
- Modular construction allows for easy retrofit and planned upgrades
- Fast, easy setup via display or software
- IEC 60687 Class 0.5s accuracy for tariff metering
- Certified for revenue metering
- Multiple installation options - direct 4-wire Wye, 3-wire Wye, 3-wire Delta, Direct Delta, and single phase

Power management solutions

Schneider Electric provides innovative power management solutions to increase your energy efficiency and cost savings, maximise electrical network reliability and availability, and optimise electrical asset performance.

Conformity of standards

- | | |
|----------------|-----------------|
| • EN 61000-4-2 | • IEC 61000-4-2 |
| • EN 61000-4-3 | • IEC 61000-4-3 |
| • EN 61000-4-4 | • IEC 61000-4-4 |
| • EN 61000-4-5 | • IEC 61000-4-5 |
| • EN 61000-4-6 | • IEC 61000-4-6 |
| • EN 61010-1 | • IEC 61000-6-2 |
| • IEC 61010-1 | |

optimizer

ION6200

ION6200 feature selection		ION6200 Standard	ION6200 EP1	ION6200 EP2
Performance standard				
IEC61557-12 PMD/Sx/K55/0.5		■	■	■
General				
Use on LV and HV systems		■	■	■
Current and voltage accuracy		0.3%	0.3%	0.3%
Energy and power accuracy		0.5%	0.5%	0.5%
Number of samples per cycle		64	64	64
Instantaneous rms values				
Current and voltage		■	■	■
Frequency			■	■
Active, power	Total		■	■
	Per phase			■
Reactive and apparent power	Total			■
	Per phase			■
Power factor	Total		■	■
	Per phase			■
Energy value				
Active energy			■	■
Reactive, apparent energy				■
Demand value				
Current	Present and max		■	■
	Present			■
Active power	Max		■	■
	Present and max			■
Reactive and apparent power				■
Power quality measurements				
Harmonic distortion	Current, voltage			■
Display and I/O				
LED display		■	■	■
Pulse output		■	■	■
Direct voltage connection (V AC)		400/690	400/690	400/690
Communication				
RS-485 port		■	■	■
ION compatibility		■	■	■
Modbus RTU protocol		■	■	■

See your Schneider Electric representative for complete ordering information.

ION6200

ION6200 feature selection		
Electrical characteristics		
Type of measurement		True rms electrical parameters Up to 64 samples per cycle
Measurement accuracy	Current	≥5 % of full scale
		<5 % of full scale
		I4 derivation
	Voltage	L-N 0.3 % reading, L-L 0.5 % reading
	Power	IEC 60687 Class 0.5, ANSI 12.20 Class 0.5
	Frequency	0.1 % reading
	Power factor	1.0 % reading
	Energy	IEC 60687 Class 0.5, ANSI 12.20 Class 0.5
Harmonic distortion		Total harmonic distortion + 1.0 %
Input-voltage characteristics	Measurement range	60-400 L-N (103.5-690 L-L) V AC RMS (3 phase) 60-400 L-N V AC (single phase)
	Impedance	2 MW /phase
	Inputs	V1, V2, V3, Vref
	Overload	1500 V AC RMS continuous
	Dielectric withstand	>3250 V AC RMS; 60 Hz for 1 minute
Input-current characteristics	Rated inputs	5 A nominal /10 A full scale RMS (+20% overrange with full accuracy, 300 V RMS to ground)
	Permissible overload	120 A RMS for 1 second, non-recurring
	Starting current	0,005 A RMS
	Burden	0.05 VA (typical) @ 5 A RMS
	Inputs	I1, I2, I3
	Dielectric withstand	3000 V RMS for 1 minute
Power supply	AC	Standard: 100-240 V AC, 50-60 Hz
	DC	Standard: 110-300 V DC, Low Voltage DC: 20-60 V DC
Inputs/outputs	Digital outputs	2 optically isolated digital outputs for KY pulsing or control Max forward current: 150 mA Max voltage: 200 V Max current: 150 mA
	RS-485 port	Optically isolated
Mechanical characteristics		
Weight		0.68 kg
IP degree of protection (IEC 60529)		Meter with display: front IP 65, back IP 30; Transducer unit (no integrated display): IP 30 Remote display unit: front IP 65; back IP 30
Dimensions		Basic unit installed depth: 106.7x106.7x40.6 mm Remote display: 106.7x106.7x22.9 mm
Environmental conditions		
Operating temperature		-20° C to 70° C ambient air
Storage temperature		-40° C to 85° C
Humidity rating		5 % to 95 % non-condensing
Pollution degree		2
Installation category		III (Distribution)
Electromagnetic compatibility industrial environments		

ION6200

ION6200 feature selection		
Electromagnetic compatibility		
Electrostatic discharge		IEC 61000-4-2 (EN61000-4-2/IEC801-2)
Immunity to radiated fields		IEC 61000-4-3 (EN61000-4-3/IEC801-3)
Immunity to fast transients		IEC 61000-4-4 (EN61000-4-4/IEC801-4)
Surge immunity		IEC 61000-4-5 (EN61000-4-5/IEC801-5)
Conducted immunity		IEC 61000-4-6 (EN61000-4-6/IEC801-6)
Electromagnetic compatibility for industrial environments		IEC 61000-6-2
Safety		
Standards		cUL compliant to CSA C22.2 No. 1010-1
		IEC1010-1 (EN61010-1)
		UL 3111-1
Communications		
RS-485 port		Up to 19 200 bps, Modbus RTU, ION compatible protocol
Display		
Bright LED display		19 mm high digits
		Displays all basic power parameters
		Easy setup for common configuration parameters
		Password protection on setup parameters
		Password protection for demand reset
Megawatt options		
MegaWatt option on meter base with integrated display. Not available for RMICAN or RMICAN-sealed meters		MO
MegaWatt option on Transducer model with DIN rail mount, Remote Display and 4.2 m cable (RJ11, 6 conductor, 26 gauge). Not available with Security options RMICAN or RMICAN-SEAL.		N1
MegaWatt option on Transducer model with DIN rail mount, Remote Display and 2 m cable (RJ11, 6 conductor, 26 gauge). Not available with Security options RMICAN or RMICAN-SEAL.		N2
MegaWatt option on Transducer model with DIN rail mount, Remote Display and 9 m cable (RJ11, 6 conductor, 26 gauge). Not available with Security options RMICAN or RMICAN-SEAL.		N3
Options card		
1 Standard Measurements		Z0A0N
2 Enhanced Package #1		Z0A0P
3 Enhanced Package #2		Z0A0R
4 Standard Measurements, two pulse outputs		Z0B0N
5 Enhanced Package #1, two pulse outputs		Z0B0P
6 Enhanced Package #2, two pulse outputs		Z0B0R
7 Standard Measurements, RS-485		A0A0N
8 Enhanced Package #1, RS-485		A0A0P
9 Enhanced Package #2, RS-485		A0A0R
10 Standard Measurements, two pulse outputs, RS-485		A0B0N
11 Enhanced Package #1, two pulse outputs, RS-485		A0B0P
12 Enhanced Package #2, two pulse outputs, RS-485		A0B0R
Remote modular display (RMD)		
Model		M620D
Display type	Standard display	R
	For use with Transducer meter base with MegaWatt option	N
Cable length	No Cable	0
	4.2 m cable connecting RMD to Transducer meter base	1
	2 m cable connecting RMD to Transducer meter base	2
	9 m cable connecting RMD to Transducer meter base	3

ION6200 feature selection		
Part numbers		
Part	Code	Description
1 Model	M6200	A
2 Form factor	A0	Integrated display model
	R1	Transducer model with DIN rail mount, Remote Display and 4.2 gauge)
	R2	Transducer model with DIN rail mount, Remote Display and 2 n
	R3	Transducer model DIN rail mount, Remote Display and 9 m cat
	T1	Transducer model with DIN rail mount (requires Comms or pulse
3 Current inputs	A	10 Amp current inputs (12 A max)
4 Voltage inputs	0	Autoranging (57-400 V AC L-N / 99-690 V AC L-L)
5 Power supply	A	AC Standard: 100-240 V AC, 50-60 Hz
	B	DC Standard: 110-300 V DC, Low Voltage DC: 20-60 V DC
6 System frequency	0	Calibrated for use with 50 Hz or 60 Hz systems
7 Communications	Z0	No communications
	A0	Single RS-485 port (supports Modbus RTU protocol and ION-c
8 I/O	A	No I/O
	B	This option activates the two Form A digital outputs for kWh, kv
9 Security	0	No hardware lock (setup is password protected)
	2	RMANSI: Revenue Meter approved for use in the United States C12.20 class 0.5 accuracy at 23° C; 10 A current inputs only)
	3	RMICAN: Measurement Canada approved revenue meter for u
	4	RMICAN-SEAL: Factory-sealed and Measurement Canada app
10 Measurement package	N	Standard Measurements (Volts/Amps per phase and avg)
	P	Enhanced Package #1 (Standard Measurements plus Energy/f total, Neutral Current
	R	Enhanced Package #2 (all measurements)
Power supply	P620PB	Standard plug-in power supply (100-240 V AC / 50-60 Hz or 110-300 V DC)
	P620PC	Low voltage DC plug-in power supply (20-60 V DC)

ION6200 integrated model dimensions

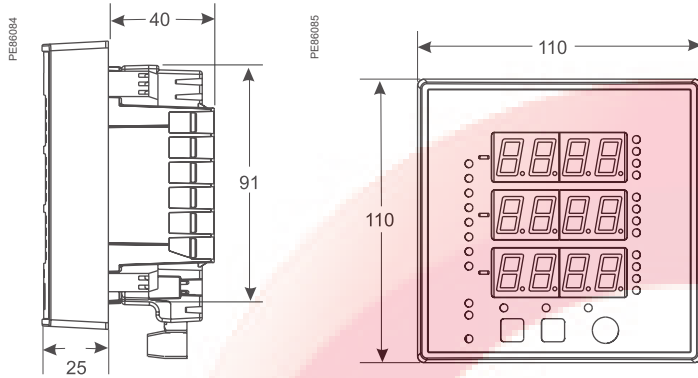

Mounting integrated model - ANSI 4" (4 1/2" Switchboard)

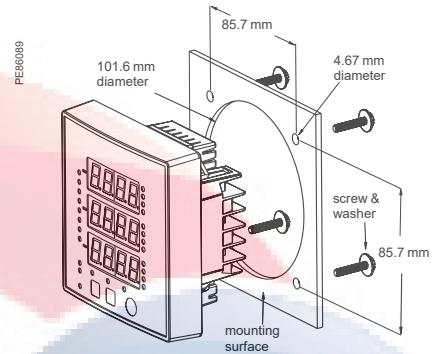

ION6200 TRAN model dimensions

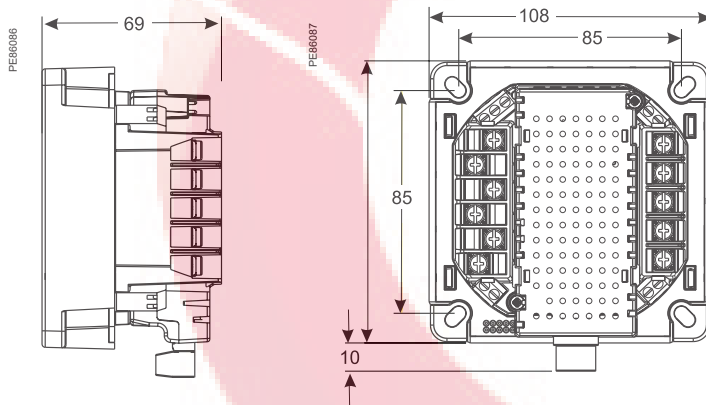

Mounting integrated model - DIN 96

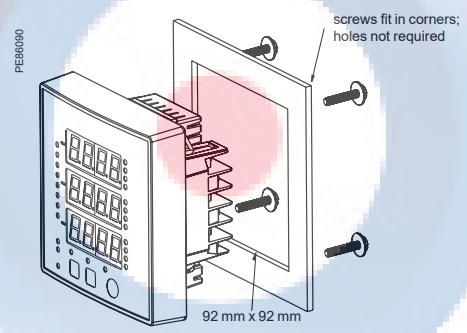

ION6200 RMD dimensions

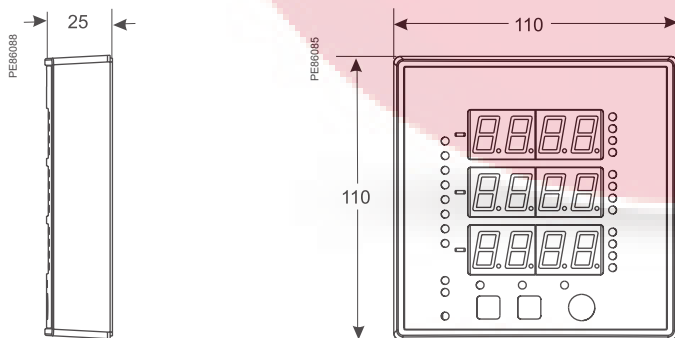

Mounting the TRAN model

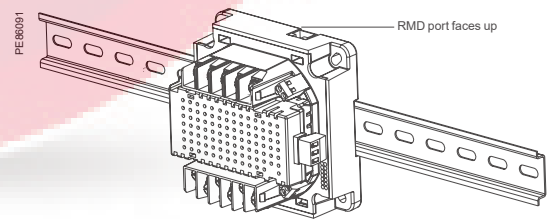

optimizer

PM3000 series

The PowerLogic PM3000 series power meters are a cost-attractive, feature-rich range of DIN rail-mounted power meters that offers all the measurement capabilities required to monitor an electrical installation.

Ideal for power metering and network monitoring applications that seek to improve the availability and reliability of your electrical distribution system, the meters are also fully capable of supporting sub-metering and cost allocation applications.

Applications

Cost management applications

- Bill checking to verify that you are only charged for the energy you use
- Aggregation of energy consumption, including WAGES, and cost allocation per area, per usage, per shift or per time within the same facility
- Energy cost and usage analysis per zone, per usage or per time period to optimise energy usage

Network management applications

- Metering of electrical parameters to better understand the behaviour of your electrical distribution system

PE108447



METSEPM3250

The solution for

All markets that can benefit from a solution that includes PowerLogic PM3000 series meters:

- Buildings
- Industry
- Data centres and networks
- Infrastructure (e.g. airports, road tunnels, telecom)

Benefits

Optimise your energy consumption & enable energy efficiency practices

- Collect and analyse energy consumption data from each area for each type of load or circuit
- Gain an accurate understanding of business expenses by allocating the energy-related costs
- Identify savings opportunities
- Use information to implement actions designed to reduce energy consumption

Competitive advantages

Connectivity advantages

- Programmable digital input
 - External tariff control signal (4 tariff)
 - Remote reset partial counter
 - External status like breaker status
 - Collect WAGES pulses
 - Programmable digital output
 - Alarm (PM3255)
 - KWh pulses
 - Graphic LCD display
 - Modbus RS-485 with screw terminals
 - Multi-tariff capability
- The PM3000 series allows users to arrange KWh consumption in four different registers. This can be controlled by:
- Digital inputs. Signal can be provided by PLC or utilities
 - Internal clock programmable by HMI
 - Through communication

This function allows users to:

- Make tenant metering for dual source applications to differentiate backup source or utility source
- Understand well the consumption during peak time and off-peak time, weekdays and weekends, holiday and working days etc.
- Follow up feeders consumption in line with utility tariff rates

Power management solutions

Schneider Electric provides innovative power management solutions to increase your energy efficiency and cost savings, maximise electrical network reliability and availability, and optimise electrical asset performance.

Conformity of standards

- | | |
|----------------|----------------|
| • IEC 61557-12 | • IEC 62053-23 |
| • IEC 61326-1 | • EN 50470-1 |
| • IEC 62052-11 | • EN 50470-3 |
| • IEC 62053-21 | • IEC 61010-1 |
| • IEC 62053-22 | • EN 55022 |

Optimizar

PM3000 series

PM3000 series feature selection		PM3200	PM3210	PM3250	PM3255
Performance standard					
IEC61557-12 PMD/Sx/K55/0.5		■	■	■	■
General					
Use on LV and HV systems		■	■	■	■
Number of samples per cycle		32	32	32	32
CT input 1A/5A		■	■	■	■
VT input		■	■	■	■
Multi-tariff		4	4	4	4
Multi-lingual backlit display		■	■	■	■
Instantaneous rms values					
Current, voltage	Per phase and average	■	■	■	■
Active, reactive, apparent power	Total and per phase	■	■	■	■
Power factor	Total and per phase	■	■	■	■
Energy values					
Active, reactive and apparent energy; import and export		■	■	■	■
Demand value					
Current, power (active, reactive, apparent) demand; present		■	■	■	■
Current, power (active, reactive, apparent) demand; peak		■	■	■	■
Power quality measurements					
THD Current and voltage		■	■	■	■
Data recording					
Min/max of the instantaneous values		■	■	■	■
Power demand logs					■
Energy consumption log (day, week, month)					■
Alarms with timestamping			5	5	15
Digital inputs/digital outputs			0/1		2/2
Communication					
RS-485 port				■	■
Modbus protocol				■	■
Commercial reference number		METSEPM3200	METSEPM3210	METSEPM3250	METSEPM3255

See your Schneider Electric representative for complete ordering information.

PM3000 series

PM3000 technical specifications

Type of measurement	True rms up to the 15th harmonic on three-phase (3P,3P+N) and single-phase AC systems. 32 samples per cycle
Measurement accuracy	
Current with x/5A CTs	0.3 % from 0.5 A to 6 A
Current with x/1A CTs	0.5 % from 0.1 A to 1.2 A
Voltage	0.3 % from 50 V to 330 V (Ph-N), from 80 V to 570 V (Ph-Ph)
Power factor	±0.005 from 0.5 A to 6 A with x/5 A CTs; from 0.1A to 1.2 A with x/1 A CTs and from 0.5 L to 0.8 C
Active/Apparent Power with x/5A CTs	Class 0.5
Active/Apparent Power with x/1A CTs	Class 1
Reactive power	Class 2
Frequency	0.05 % from 45 to 65 Hz
Active energy with x/5A CTs	IEC 62053-22 Class 0.5s
Active energy with x/1A CTs	IEC 62053-21 Class 1
Reactive energy	IEC 62053-23 Class 2
Data update rate	
Update rate	1s
Input-voltage characteristics	
Measured voltage	50 V to 330 V AC (direct / VT secondary Ph-N) 80 V to 570 V AC (direct / VT secondary Ph-Ph) up to 1 MV AC (with external VT)
Frequency range	45 Hz to 65 Hz
Input-current characteristics	
CT primary	Adjustable from 1 A to 32767 A
CT secondary	1 A or 5 A
Measurement input range with x/5A CTs	0.05 A to 6 A
Measurement input range with x/1A CTs	0.02 A to 1.2 A
Permissible overload	10 A continuous, 20 A for 10s/hour
Control Power	
AC	100/173 to 277/480 V AC (+/-20%), 3 W/5 VA; 45 Hz to 65 Hz
DC	100 to 300 V DC, 3 W
Input	
Digital inputs (PM3255)	11 to 40 V DC, 24 V DC nominal, ≤4mA maximum burden, 3.5kVrms insulation
Output	
Digital output (PM3210)	Optocoupler, polarity sensitive, 5 to 30 V, 15 mA max, 3.5kVrms insulation
Digital outputs (PM3255)	Solid state relay, polarity insensitive, 5 to 40 V, 50 mA max, 50 Ω max, 3.5kVrms insulation

PM3000 series

PM3000 technical specifications

Mechanical characteristics	
Weight	0.26 kg
IP degree of protection (IEC 60529)	IP40 front panel, IP20 meter body
Dimension	90 x 95 x 70 mm
Environmental conditions	
Operating temperature	-25 °C to 55 °C
Storage temperature	-40 °C to 85 °C
Humidity rating	5 to 95% RH at 50 °C (non-condensing)
Pollution degree	2
Metering category	III, for distribution systems up to 277/480 V AC
Dielectric withstand	As per IEC61010-1, Doubled insulated front panel display
Altitude	3000 m max
Electromagnetic compatibility	
Electrostatic discharge	Level IV (IEC 61000-4-2)
Immunity to radiated fields	Level III (IEC 61000-4-3)
Immunity to fast transients	Level IV (IEC 61000-4-4)
Immunity to surge	Level IV (IEC 61000-4-5)
Conducted immunity	Level III (IEC 61000-4-6)
Immunity to power frequency magnetic fields	0.5mT (IEC 61000-4-8)
Conducted and radiated emissions	Class B (EN 55022)
Safety	
	CE as per IEC 61010-1★
Communication	
RS-485 port	Half duplex, from 9600 up to 38400 baud, Modbus RTU (double insulation)
Display characteristics	
Dimensions (VA)	43 mm x 34.6 mm
Display resolution	128 x 96 dots
Standard compliance	
	IEC 61557-12, EN 61557-12 IEC 61010-1, UL 61010-1 IEC 62052-11, IEC 62053-21, IEC 62053-22, IEC 62053-23 EN 50470-1, EN 50470-3

★ Protected throughout by double insulation

PM3200 series front of meter

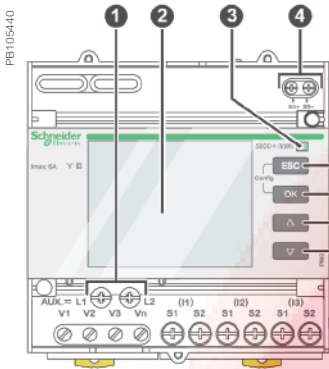

- Front of meter parts**
- 1 Control power
 - 2 Display with white backlight
 - 3 Flashing yellow meter indicator (to check accuracy)
 - 4 Pulse output for remote transfer (PM3210)
 - 5 ESC Cancellation
 - 6 OK Confirmation
 - 7 ▲ Up
 - 8 ▼ Down

PM3200 series dimensions

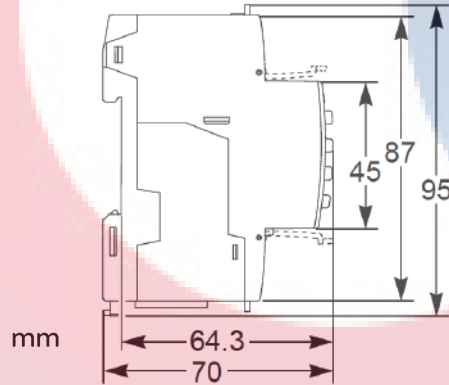
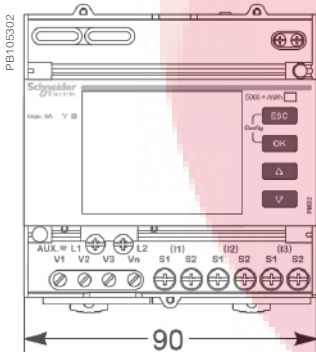

PB105447

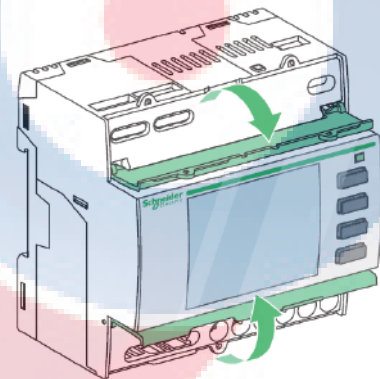

PM3200 top and lower flaps

PM3200 series easy installation

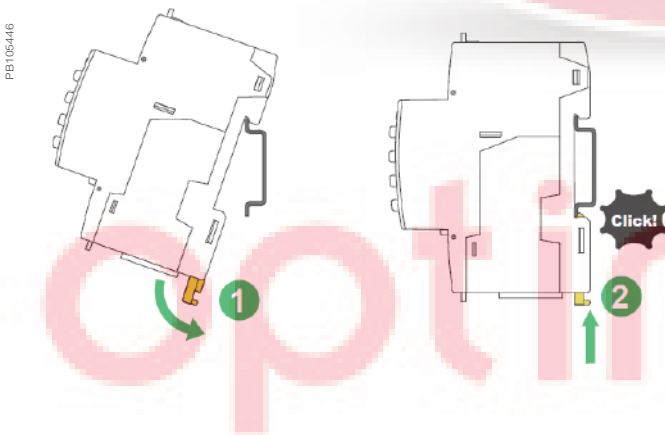

Please see the appropriate **Installation Guide** for accurate and complete information on the installation of this product.

PM5350 series

The PowerLogic PM5350 series power meters are the new benchmark in affordable, precision metering.

The PowerLogic PM5350 power meter offers all the measurement capabilities required to monitor an electrical installation in a space-efficient, single 96 x 96 mm unit with small depth. DNC certifies for marine applications.

Applications

- Panel instrumentation.
- Cost allocation or energy management
- Electrical installation remote monitoring
- Sophisticated alarming
- Circuit breaker monitoring and control

PE66278

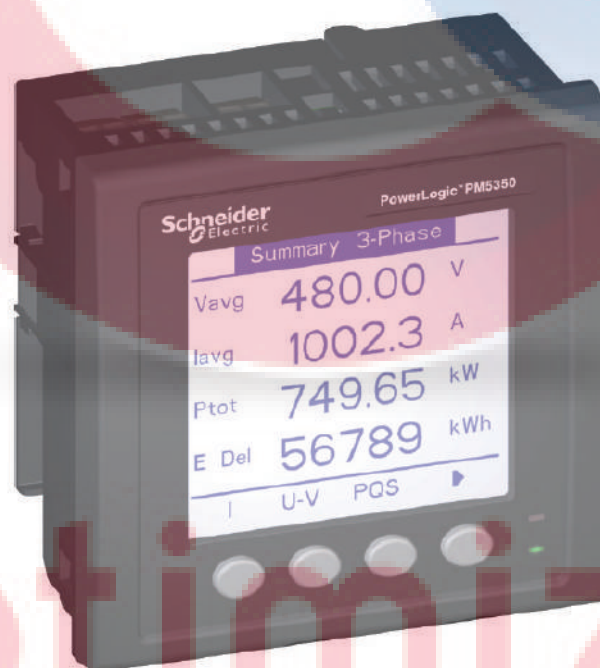

METSEPM5350

The solution for

Markets that can benefit from a solution that includes PowerLogic PM5350 series meters:

- Buildings
- Industry
- Healthcare
- Data Centre and networks
- Infrastructure

Benefits

System integrators' benefit

- Ease of integration
- Ease of setup
- Cost effectiveness

Panel builders' benefit

- Ease of installation
- Cost effectiveness
- Aesthetically pleasing
- Simplified ordering

End users' benefit

- Ease of use
- Precision metering & sub-billing
- Billing flexibility
- Comprehensive, consistent and superior performance

Competitive advantages

- Easy to install and operate
- Easy for circuit breaker monitoring and control
- Power quality analysis
- Load management combined with alarm and timestamping
- High performance and accuracy

Power management solutions

Schneider Electric provides innovative power management solutions to increase your energy efficiency and cost savings, maximise electrical network reliability and availability, and optimise electrical asset performance.

Conformity of standards

- IEC 62053-22
- IEC 61557-12
- IEC 62053-23
- IEC 61010-1
- UL 61010-1
- IEC 61326-1
- FCC part 15 Class A
- DNV certified

optimizer



PowerLogic PM5350.

The PowerLogic PM5350 power meter offers all the measurement capabilities required to monitor an electrical installation in a single 96 x 96 mm unit extending only 44 mm behind the mounting surface.

With its large display, all three-phases and neutral can be monitored simultaneously. The bright, anti-glare display features large characters and powerful backlighting for easy reading even in extreme lighting conditions and viewing angles. The meter menus are understood by all, with the availability of three languages (English, Chinese, Spanish) included standard in the PM5350.

Its compact size and high performance make the PowerLogic PM5350 suitable for many applications.

• Applications

- Panel instrumentation.
- Cost allocation or energy management.
- Electrical installation remote monitoring.
- Alarming with under/over, digital status, control power interruption, meter reset, self diagnostic issue.
- Circuit Breaker monitoring and control with relay outputs and whetted digital inputs.
- DNV certified for marine applications.

• Main characteristics

- Easy to install
 - Mounts using two clips, no tools required. Ultra compact meter with 44 mm depth connectable up to 480 V L-L without voltage transformers for installations compliant with category III, as per IEC 61010-1. See specification table for UL voltage limits.
 - Easy to operate
 - Intuitive navigation with self-guided, language selectable menus, six lines, four concurrent values. Two LEDs on the meter face help the user confirm normal operation (heartbeat/communications indicator LED: green and other LED orange, customizable either for alarms or energy pulse outputs).
 - Easy circuit breaker monitoring and control
 - The PM5350 provides two relay outputs (high performance) with capability to command most of the circuit breaker coils directly. In addition, monitored switches can be wired directly to the meter without external power supply.
 - System status at a glance
 - Bright, anti-glare, backlit display plus two LEDs; orange for energy pulse or alarm and green for heartbeat/communications indication.
 - IEC 62053-22 class 0.5S accuracy for active energy
 - Accurate energy measurement for cost allocation.
 - Power Quality analysis
 - The PM5350 offers THD and TDD measurements as standard. Total Demand Distortion is based on a point of common coupling (PCC), which is a common point that each user receives power from the power source. The TDD compares the contribution of harmonics versus the maximum demand load.
 - Load management
 - Peak demands with timestamping are provided. Predicted demand values can be used in basic load shedding applications.
 - Alarming with timestamping
 - Over 30 alarm conditions, such as under/over conditions, digital input changes, and phase unbalance inform you of events. A time-stamped log maintains a record of the last 40 alarm events.
 - Load timer setpoint adjustable to monitor and advise maintenance requirements.
- Performance Standard Meets IEC 61557-12 PMD/Sx/K70/0.5.

Feature selection

Commercial reference number	Description
METSEPM5350	PM5350 Power & Energy meter with THD alarming
METSEPM5350P	PM5350 Power & Energy Meter with THD, Alarming, Multi-tariff and Individual Harmonics

PM5350 series

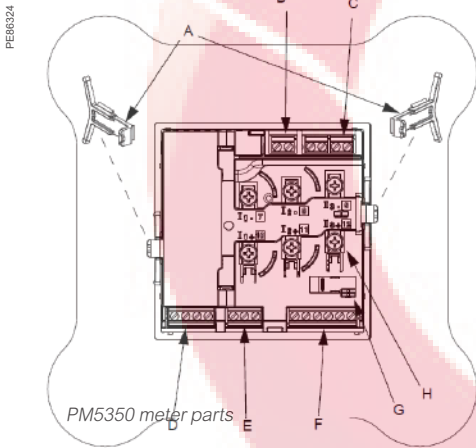
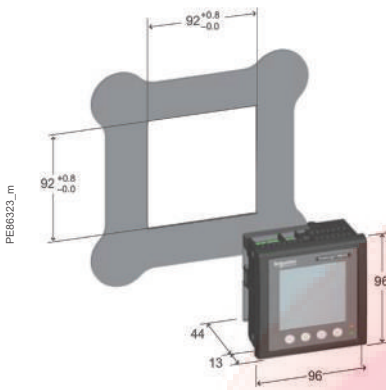

- A Retainer clips.
- B Control power supply connector.
- C Voltage inputs.
- D Digital outputs.
- E RS-485 port (COM1).
- F Digital input.
- G Optical revenue switch.
- H Current inputs.

PM5350 technical specifications

General		
Use on LV and MV systems		■
Basic metering with THD and min/max readings		■
Instantaneous rms values		
Current	Total, Phases and neutral	■
Voltage	Total, Ph-Ph and Ph-N	■
Frequency		■
Real, reactive, and apparent power	Total and per phase	Signed
True Power Factor	Total and per phase	Signed, Four Quadrant
Displacement PF	Total and per phase	Signed, Four Quadrant
Unbalanced I, VL-N, VL-L		■
Energy values		Stored in non-volatile memory
Accumulated Active, Reactive and Apparent Energy	Received/Delivered; Net and absolute;	■
Demand values		
Current average	Present, Last, Predicted, Peak, & Peak Date Time	■
Active power	Present, Last, Predicted, Peak, & Peak Date Time	■
Reactive power	Present, Last, Predicted, Peak, & Peak Date Time	■
Apparent power	Present, Last, Predicted, Peak, & Peak Date Time	■
Peak demand with timestamping D/T for current & powers		■
Demand calculation	Sliding, fixed and rolling block, thermal	■
Synchronization of the measurement window		■
Other measurements		
I/O timer		■
Operating timer		■
Active load timer		■
Alarm counters		■
Power quality measurements		
THD, thd (Total Harmonic Distortion)		I, V L-N, V L-L
TDD, thd (Total Demand Distortion)		■
Data recording		
Min/max of instantaneous values, plus phase identification		■
Alarms with 1s timestamping		Standard 29; Unary 4; Digital 4
Alarms stored in non-volatile memory		40 events
Inputs/Outputs		
Digital inputs		4 (DI1, DI2, DI3, DI4)
Digital outputs		2 relay outputs (DO1, DO2)
Display		
White backlit LCD display, 6 lines, 4 concurrent values		■
IEC or IEEE visualization mode		■
Communication		
Modbus RTU, Modbus ASCII, Jbus Protocol		■
Firmware update via RS-485 serial port (DLF3000 via the Schneider Electric website: www.schneider-electric.com)		■

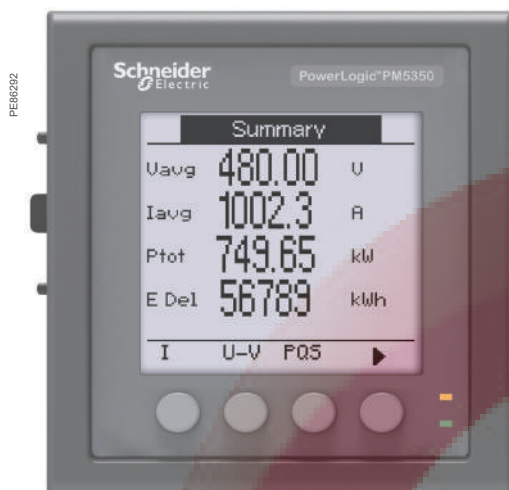

Front screen view of PM5350.

Electrical characteristics		
Type of measurement		True rms up to the 15th harmonic on three-phase (3P, 3P + N) 32 samples per cycle, zero blind
Measurement accuracy	Current, Phase ★	±0.30 %
	Voltage, L-N ★	±0.30 %
	Power Factor ★	±0.005
	Power, Phase	IEC 61557-12 Class 0.5; For 5 A nominal CT (for 1 A nominal CT when I > 0.15 A) ±0.5 % from 0.25 A to 9.0 A at COS φ = 1 ±0.6 % from 0.50 A to 9.0 A at COS φ = 0.5 (ind or cap)
	Frequency★	±0.05 %
	Real Energy	IEC 62053-22 Class 0.5 S; IEC 61557-12 Class 0.5; For 5 A nominal CT (for 1 A nominal CT when I > 0.15 A) ±0.5 % from 0.25 A to 9.0 A at COS φ = 1 ±0.6 % from 0.50 A to 9.0 A at COS φ = 0.5 (ind or cap) IEC 61557-12 Class 0.5
Reactive Energy	IEC 62053-23 Class 3; IEC 61557-12 Class 2 For 5 A nominal CT (for 1 A nominal CT when I > 0.15 A) ±2.0 % from 0.25 A to 9.0 A at SIN φ = 1 ±2.5 % from 0.50 A to 9.0 A at SIN φ = 0.5 (ind or cap)	
Data update rate		1 second nominal (50/60 cycles)
Input-voltage	VT primary	1.0 MV AC max, starting voltage depends on VT ratio.
	U nom	277 V L-N
	Measured voltage with overrange & Crest Factor	IEC: 20 to 480 V AC L-L; 20 to 277 V AC L-N, CAT III IEC: 20 to 690 V AC L-L; 20 to 400 V AC L-N, CAT II UL: 20 to 300 V AC L-L, CAT III
	Permanent overload	700 V AC L-L, 404 V AC L-N
	Impedance	10 MΩ
	Frequency range	45 to 70 Hz
Input-current	CT ratings Secondary	1A, 5 A nominal
	Measured voltage with overrange & crest factor	5 mA to 9 A
	Withstand	Continuous 20 A, 10 sec/hr 50 A, 1 sec/hr 500 A
	Impedance	< 0.3 mΩ
	Frequency range	45 to 70 Hz
	Burden	< 0.024 VA at 9 A
AC control power	Operating range	85 - 265 V AC
	Burden	4.1 VA / 1.5 W typical, 6.7 VA / 2.7 W max at 120 V AC 6.3 VA / 2.0 W typical, 8.6 VA / 2.9 W max at 230 V AC 9.6 VA / 3.5 W maximum at 265 V AC
	Frequency	45 to 65 Hz
	Ride-through time	100 mS typical at 120 V AC and maximum burden 400 mS typical at 230 V AC and maximum burden
DC control power	Operating range	100 to 300 V DC
	Burden	1.4 W typical, 2.6 W maximum at 125 V DC 1.8 W typical, 2.7 W maximum at 250 V DC 3.2 W maximum at 300 V DC
	Ride-through time	50 mS typical at 125 V DC and maximum burden
Real time clock	Ride-through time	30 seconds
Digital output	Number/Type	2 - Mechanical Relays
	Output frequency	0.5 Hz maximum (1 second ON / 1 second OFF - minimum times)
	Switching Current	250 V AC at 2.0 Amps, 200 k cycles, resistive 250 V AC at 8.0 Amps, 25 k cycles, resistive 250 V AC at 2.0 Amps, 100 k cycles, COS φ=0.4 250 V AC at 6.0 Amps, 25 k cycles, COS φ=0.4 30 V DC at 2.0 Amps, 75 k cycles, resistive 30 V DC at 5.0 Amps, 12.5 k cycles, resistive
	Isolation	2.5 kVrms
	Status Digital Inputs	Voltage ratings ON 18.5 to 36 V DC, OFF 0 to 4 V DC Input Resistance 110 kΩ Maximum Frequency 2 Hz (T ON min = T OFF min = 250 ms) Response Time 10 ms Isolation 2.5 kVrms
Whetting output	Nominal voltage	24 V DC
	Allowable load	4 mA
	Isolation	2.5 kVrms

★ Measurements taken from 45 Hz to 65 Hz, 0.5 A to 9 A, 57 V to 347 V & 0.5 ind to 0.5 cap power factor with a sinusoidal wave.

PM5350 series

PM5350 technical specifications

Mechanical characteristics		
Weight		250 g
IP degree of protection (IEC 60529)		IP51 front display, IP30 meter body (excluding connectors)
Dimensions	W x H x D	96 x 96 x 44 mm (depth of meter from housing mounting flange) 96 x 96 x 13 mm (protrusion of meter from housing flange)
Mounting position		Vertical
Panel thickness		6.35 mm max
Environmental characteristics		
Operating temperature	Meter	-25 °C to 70 °C
	Display	-20 °C to 70 °C (Display functions to -25 °C with reduced performance)
Storage temp.	Meter + display	-40 °C to 85 °C
Humidity rating		5 % to 95 % RH at 50 °C (non-condensing)
Pollution degree		2
Altitude		3000 m max
Indoor use only	Not suitable for wet locations	
Electromagnetic compatibility		
Electrostatic discharge		IEC 61000-4-2★
Immunity to radiated fields		IEC 61000-4-3★
Immunity to fast transients		IEC 61000-4-4★
Immunity to impulse waves		IEC 61000-4-5★
Conducted immunity		IEC 61000-4-6★
Immunity to magnetic fields		IEC 61000-4-8★
Immunity to voltage dips		IEC 61000-4-11★
Radiated emissions		FCC part 15 class A, EN 55011 Class A
Conducted emissions		FCC part 15 class A, EN 55011 Class A
Harmonics		IEC 61000-3-2★
Flicker emissions		IEC 61000-3-3★
Safety		
Europe		CE, as per IEC 61010-1
U.S. and Canada		cULus as per UL 61010-1, IEC 61010-1 (3rd Edition)
Measurement category (Voltage and current inputs)		Per IEC 61010-1: CAT III, 277 V L-N / 480 V L-L nominal; CAT II 400 V L-N / 690 V L-L nominal Per UL 61010-1 and CSA C22.2 No. 61010-1: CAT III, 300 V L-L
Overvoltage Category (Control power)		CAT III
Dielectric		As per IEC 61010-1 Double insulated front panel display
Protective Class		Class II
Communication		
RS-485 port		2-Wire, 9600,19200 or 38400 baud, Parity - Even, Odd, None, 1 stop bit if parity Odd or Even, 2 stop bits if None; Modbus RTU, Modbus ASCII (7 or 8 bit), JBUS
Firmware and language file update		Update via communication port using DLF3000 software
Isolation		2.5 kVrms, double insulated
Human machine interface		
Display type		Monochrome Graphics LCD
Resolution		128 x 128
Backlight		White LED
Viewable area (W x H)		67 x 62.5 mm
Keypad		4-button
Indicator Heartbeat / Comm activity		Green LED
Energy pulse output / Active alarm indication (configurable)		
Type		Optical, amber LED
Wavelength		590 to 635 nm
Maximum pulse rate		2.5 kHz

★ As per IEC 61557-12

Rear of meter - open

PE86279

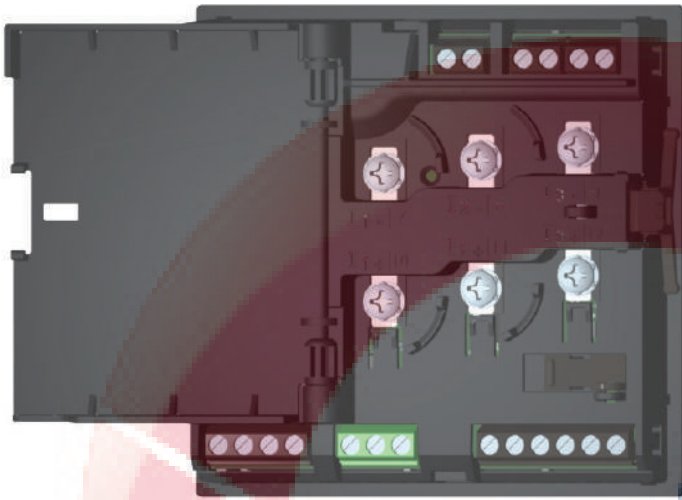

Rear view retainers - installation

PE86274

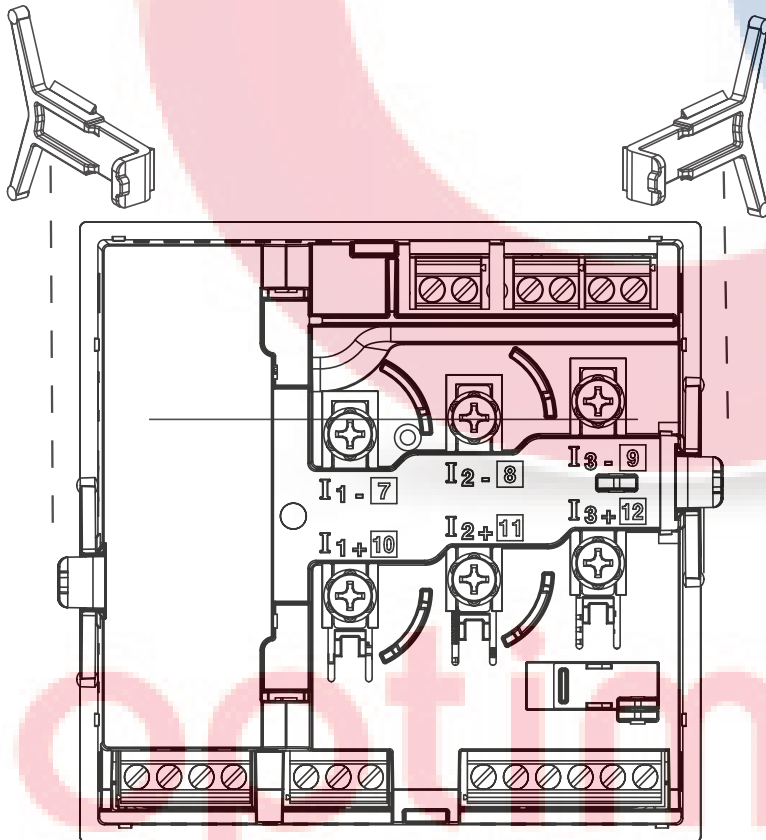

For detailed installation instructions see the product's Installation Guide.

Rear view retainers - users

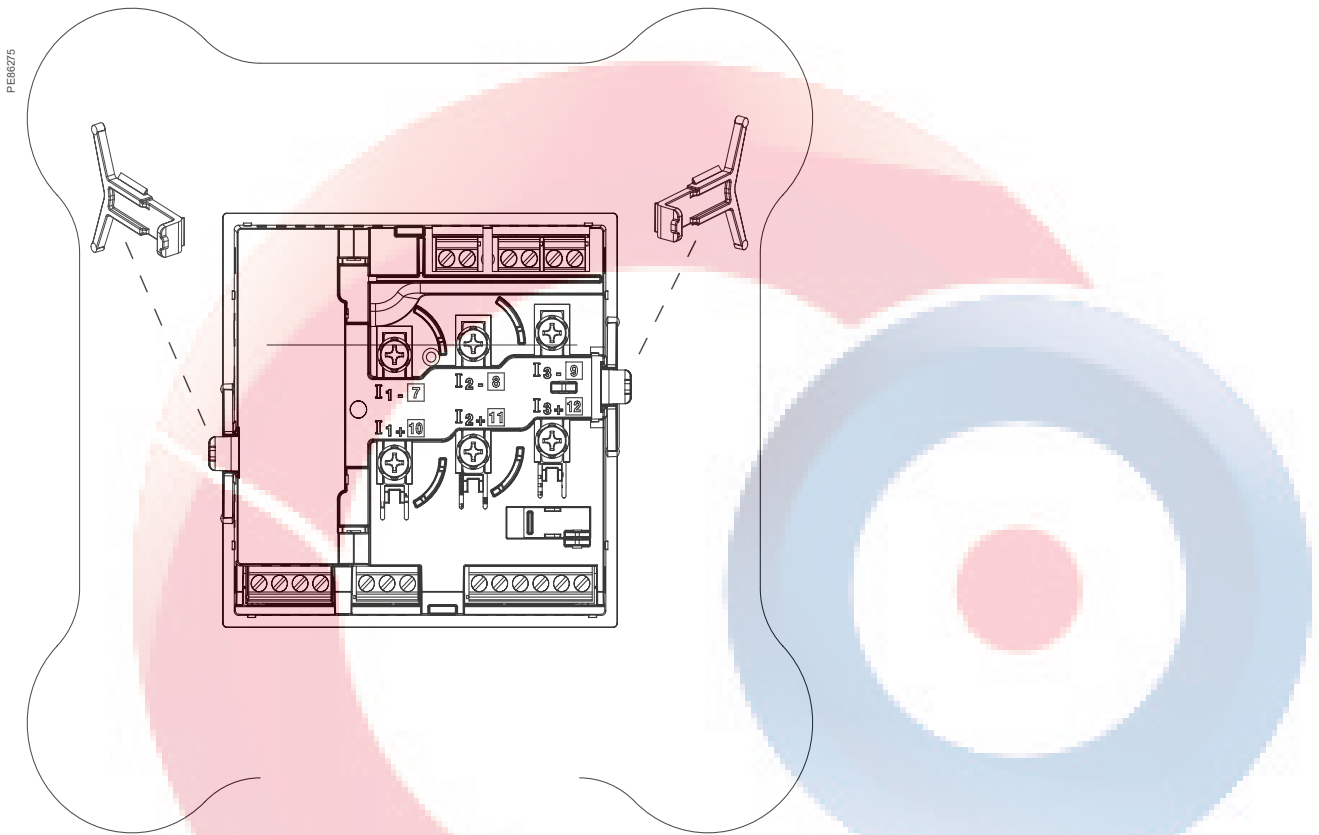

For detailed installation instructions see the product's Installation Guide.

optimizer

PM5350IB and PM5350PB series

The PowerLogic PM5350IB and PM5350PB series power meters are the new benchmark in affordable, precision metering.

The PowerLogic PM5350P power meter offers all the measurement capabilities required to monitor an electrical installation in a space-efficient, single 96 x 96 mm unit.

Applications

- Panel instrumentation.
- Cost allocation or energy management
- Electrical installation remote monitoring.
- Sophisticated alarming
- Circuit Breaker monitoring and control

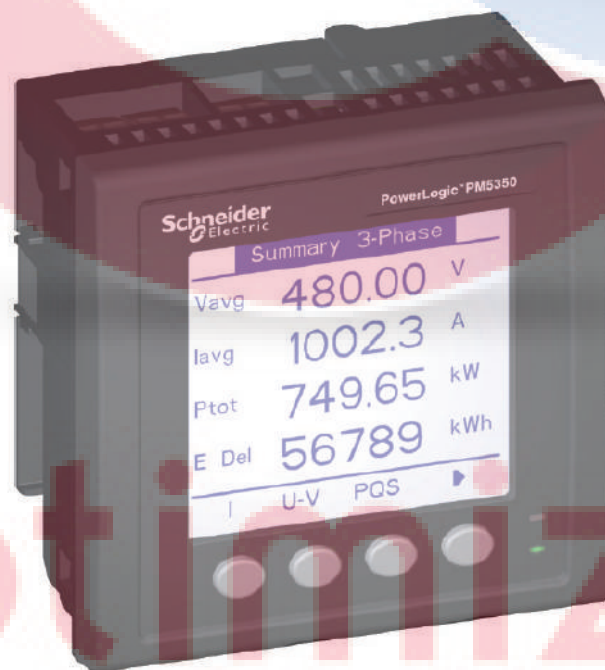

METSEPM5350IB

PIE66278

The solution for

Markets that can benefit from a solution that includes PowerLogic PM5350IB and PM5350PB series meters:

- Buildings
- Industry
- Healthcare
- Data Centre and networks
- Infrastructure

Benefits

System integrators' benefit

- Ease of integration
- Ease of setup
- Cost effectiveness

Panel builders' benefit

- Ease of installation
- Cost effectiveness
- Aesthetically pleasing
- Simplified ordering

End users' benefit

- Ease of use
- Precision metering & sub-billing
- Billing flexibility
- Comprehensive, consistent and superior performance

Competitive advantages

- Easy to install and operate
- Easy for circuit breaker monitoring and control
- Power quality analysis
- Load management combined with alarm and timestamping
- High performance and accuracy

Power management solutions

Schneider Electric provides innovative power management solutions to increase your energy efficiency and cost savings, maximise electrical network reliability and availability, and optimise electrical asset performance.

Conformity of standards

- IEC 62053-22
- IEC 61010-1
- IEC 61557-12
- UL 61010-1
- IEC 62053-23
- IEC 61000-4-2
- IEC 61326-1
- IEC 61000-4-3

optimizer

PE80278



PowerLogic PM5350IB

The PM5350IB and PM5350PB are compact multi-circuit power meters specially designed to monitor Busway power distribution systems. They provide consumption and alarm data by circuit, for up to three single-phase circuits and can also be installed in different electrical configurations, monitoring 1-, 2-, and 3-phase circuits. These meters are an ideal solution for cost management and sub-billing in data centres.

With its large display, all individual circuits can be monitored simultaneously. The bright, anti-glare display features large characters and powerful backlighting for easy reading even in extreme lighting conditions and viewing angles.

- Main characteristics
 - Easy to install
 - Mounts using two clips, no tools required. Ultra compact meter with 44 mm depth connectable up to 480 V L-L without voltage transformers. See specification table for voltage inputs details.
 - Easy to operate
 - Intuitive navigation with self-guided, language selectable menus, six lines, four concurrent values.
 - System status at a glance
 - Bright, anti-glare, backlit display plus two LEDs; orange for energy pulse or alarm and green for heartbeat/communications indication.
 - IEC 62053-22 class 0.5S accuracy for active energy

Accurate energy measurement for cost allocation and sub-billing.★

- Circuit breaker monitoring
 - Four digital inputs provide an easy way to monitor status, alarm and report on circuit breaker trips.
- Multi-level alarming
 - Five different alarm levels (high, high-high, low, low-low, tripped) optimized network management and downtime prevention.
- Performance Standard Meets IEC 61557-12 PMD/Sx/K70/0.5.

★Sub-billing might be subject to local regulation.

optimizer

Feature selection	
Commercial reference number	Description
METSEPM5350IB	PowerLogic PM5350IB
METSEPM5350PB	PowerLogic PM5350PB

PM5350IB/PB series

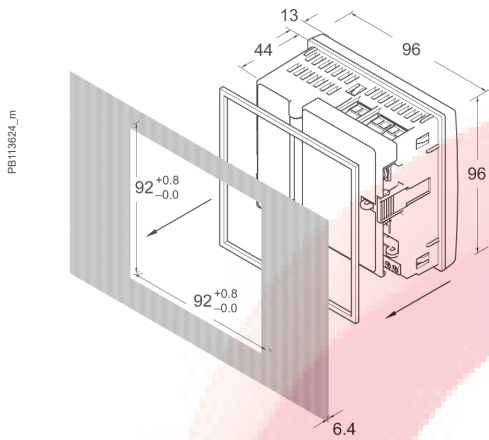

Dimensions PM5350IB

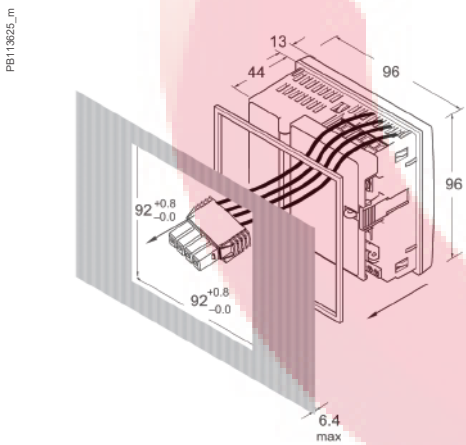

Dimensions PM5350PB

PM5350IB/PB technical specifications

General		5350IB	5350PB
Use on LV and MV systems			■
Basic metering with THD and min/max readings			■
Instantaneous rms values			
Current	Total, Phases and neutral		■
Voltage	Total, Ph-Ph and Ph-N		■
Frequency			■
Real, reactive, and apparent power	Total and per phase		Signed
True Power Factor	Total and per phase		Signed, Four Quadrant
Displacement PF	Total and per phase		Signed, Four Quadrant
Unbalanced I, V L-N, V L-L			■
Energy Total and per circuit			
Accumulated Active, Reactive and Apparent Energy★	Received/Delivered; Net and absolute		■
Demand values			
Current average★	Present, Last, Predicted, Peak, & Peak Date Time		■
Active power★	Present, Last, Predicted, Peak, & Peak Date Time		■
Reactive power★	Present, Last, Predicted, Peak, & Peak Date Time		■
Apparent power★	Present, Last, Predicted, Peak, & Peak Date Time		■
Peak demand with timestamping★			■
Power quality			
THD, thd (Total Harmonic Distortion)			I, V L-N, V L-L
TDD, thd (Total Demand Distortion)			■
Data recording total and per circuit			
Min/max of instantaneous values, plus circuit identification★			■
Alarms with 1s timestamping			Standard 29; Unary 4; Digital 4
Alarms stored in non-volatile memory★		40 events	■
Inputs/Outputs			
Digital inputs		4 (DI1, DI2, DI3, DI4)	
Digital outputs		2 relay outputs (DO1, DO2)	
Display			
White backlit LCD display, 6 lines, 4 concurrent values			■
IEC or IEEE visualization mode			■
Communication			
Modbus RTU, Modbus ASCII, Jbus Protocol			■
Firmware update via RS-485 serial port (DLF3000 via the Schneider Electric website: www.schneider-electric.com)			■

★ Stored in non-volatile memory

optimizer

PE66292

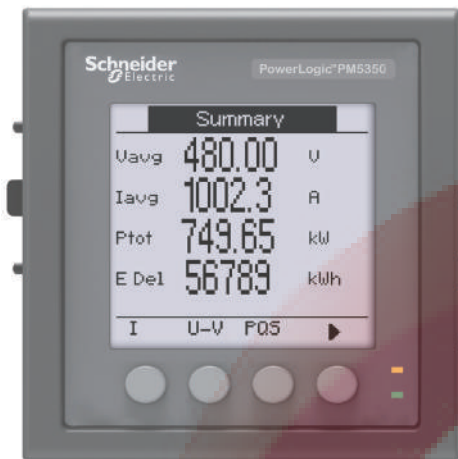

Front screen view of PM5350.

Electrical characteristics		5350IB	5350PB
Type of measurement		True rms up to the 15th harmonic 32 samples per cycle, zero blind	
Measurement accuracy	Current, Circuit ★	±0.30 %	
	Voltage, L-N ★	±0.30 %	
Power, Circuit	Power Factor ★	±0.005	
		IEC 61557-12 Class 0.5; For 5 A nominal CT (for 1 A nominal CT when I > 0.15 A) ±0.5 % from 0.25 A to 9.0 A at COS φ = 1 ±0.6 % from 0.50 A to 9.0 A at COS φ = 0.5 (ind or cap)	
Frequency ★		±0.05 %	
Real Energy		IEC 62053-22 Class 0.5 S; IEC 61557-12 Class 0.5; For 5 A nominal CT (for 1 A nominal CT when I > 0.15A) ±0.5 % from 0.25 A to 9.0 A at COS φ = 1 ±0.6 % from 0.50 A to 9.0 A at COS φ = 0.5 (ind or cap) IEC 61557-12 Class 0.5	
Reactive Energy		IEC 62053-23 Class 3, IEC 61557-12 Class 2 For 5 A nominal CT (for 1 A nominal CT when I > 0.15A) ±2.0 % from 0.25 A to 9.0 A at SIN φ = 1 ±2.5 % from 0.50 A to 9.0 A at SIN φ = 0.5 (ind or cap)	
Data update rate		1 second nominal (50/60 cycles)	
Input-voltage	VT primary	1.0 MV AC max, starting voltage depends on VT ratio.	
	U nom	277 V L-N	
	Measured voltage with overrange & Crest Factor	UL: 20 to 300 V AC L-L	UL: 20 to 480 V AC L-L
		IEC: 20 to 690 V V AC L-L; 20 to 400 V AC L-N	IEC: 20 to 690 V V AC L-L; 20 to 400 V AC L-N
	Permanent overload	700 V AC L-L, 404 V AC L-N	
	Impedance	10 M Ω	
Frequency range		45 to 70 Hz	
Input-current	CT ratings	Primary	Adjustable 1 A to 32767 A
		Secondary	1 A, 5 A nominal
	Measured voltage with overrange & Crest Factor	5 mA to 9 A	
	Withstand	Continuous 20 A, 10 sec/hr 50 A, 1 sec/hr 500 A	
	Impedance	< 0.3 mΩ	
	Frequency range	45 to 70 Hz	
AC control power	Burden	< 0.024 VA at 9 A	
	Operating range	85 to 277 V AC	
	Burden	4.1 VA / 1.5 W typical, 6.7 VA / 2.7 W max at 120 V AC 6.3 VA / 2.0 W typical, 8.6 VA / 2.9 W max at 230 V AC 9.6 VA / 3.5 W maximum at 265 V AC	
	Frequency	45 to 65 Hz	
DC control power	Ride-through time	100 mS typical at 120 V AC and maximum burden 400 mS typical at 230 V AC and maximum burden	
	Operating range	100 to 300 V DC	
Real time clock	Burden	1.4 W typical, 2.6 W maximum at 125 V DC 1.8 W typical, 2.7 W maximum at 250 V DC 3.2 W maximum at 300 V DC	
	Ride-through time	50 mS typical at 125 V DC and maximum burden	
Digital output	Ride-through time	30 seconds	
	Number/Type	2 - Mechanical Relays	
	Output frequency	0.5 Hz maximum (1 second ON / 1 second OFF - minimum times)	
	Switching Current	250 V AC at 2.0 Amps, 200 k cycles, resistive 250 V AC at 8.0 Amps, 25 k cycles, resistive 250 V AC at 2.0 Amps, 100 k cycles, COS φ = 0.4 250 V AC at 6.0 Amps, 25 k cycles, COS φ = 0.4 30 V DC at 2.0 Amps, 75 k cycles, resistive 30 V DC at 5.0 Amps, 12.5 k cycles, resistive	
	Isolation	2.5 kVrms	
Status Digital Inputs	Voltage ratings	ON 18.5 to 36 V DC, OFF 0 to 4 V DC	
	Input Resistance	110 k Ω	
	Maximum Frequency	2 Hz (T ON min = T OFF min = 250 ms)	
	Response Time	10 ms	
Whetting output	Isolation	2.5 kVrms	
	Nominal voltage	24 V DC	
	Allowable load	4 mA	
	Isolation	2.5 kVrms	

★ Measurements taken from 45 Hz to 65 Hz, 0.5 A to 9 A, 57 V to 347 V & 0.5 ind to 0.5 cap power factor with a sinusoidal wave.

PM5350IB/PB series

PM5350IB/PB technical specifications		5350IB	5350PB
Mechanical characteristics			
Weight		250 g	
IP degree of protection (IEC 60529)		IP51 front display, IP30 meter body	
Dimensions	W x H x D	96 x 96 x 44 mm (depth of meter from housing mounting flange) 96 x 96 x 13 mm (protrusion of meter from housing flange)	
Mounting position		Vertical	
Panel thickness		6.35 mm max	
Environmental characteristics (for indoor use only)			
Operating temperature	Meter	-25 °C to 70 °C	
	Display	-20 °C to 70 °C (Display functions to -25°C with reduced performance)	
Storage temp.	Meter + display	-40 °C to 85 °C	
Humidity rating		5 to 95 % RH at 50 °C (non-condensing)	
Pollution degree		2	
Altitude		3000 m max.	
Indoor use only	Not suitable for wet locations		
Electromagnetic compatibility (for indoor use only)			
Electrostatic discharge		IEC 61000-4-2★	
Immunity to radiated fields		IEC 61000-4-3★	
Immunity to fast transients		IEC 61000-4-4★	
Immunity to impulse waves		IEC 61000-4-5★	
Conducted immunity		IEC 61000-4-6★	
Immunity to magnetic fields		IEC 61000-4-8★	
Immunity to voltage dips		IEC 61000-4-11★	
Radiated emissions		FCC part 15 class A, EN 55011 Class A	
Conducted emissions		FCC part 15 class A, EN 55011 Class A	
Harmonics		IEC 61000-3-2★	
Flicker emissions		IEC 61000-3-3★	
Safety			
Europe		CE, as per IEC 61010-1	
U.S. and Canada		cULus as per UL61010-1, IEC 61010-1 (2nd Edition)	
Measurement category (Voltage and current inputs)		UL: 20 to 300 V AC L-L, CATIII IEC: 20 to 480V V AC L-L; 20 to 277 V AC L-N, CATIII 20 to 690V V AC L-L; 20 to 400 V AC L-N, CATII	UL: 20 to 480 V AC L-L, CATIII IEC: 20 to 480V V AC L-L; 20 to 277 V AC L-N, CATIII 20 to 690V V AC L-L; 20 to 400 V AC L-N, CATII
Overvoltage Category (Control power)		CAT III	
Dielectric		As per IEC 61010-1 Double insulated front panel display	
Protective Class		Class II	
Communication			
RS-485 port		2-Wire, 9600,19200 or 38400 baud, Parity - Even, Odd, None, 1 stop bit if parity Odd or Even, 2 stop bits if None; Modbus RTU, Modbus ASCII (7 or 8 bit), JBUS	
Firmware and language file update		Update via communication port using DLF3000 software	
Isolation		2.5 kVrms, double insulated	
Human machine interface			
Display type		Monochrome Graphics LCD	
Resolution		128 x 128	
Backlight		White LED	
Viewable area (W x H)		67 x 62.5 mm	
Keypad		4-button	
Indicator Heartbeat / Comm activity		Green LED	
Energy pulse output / Active alarm indication (configurable)			
Type		Optical, amber LED	
Wavelength		590 to 635 nm	
Maximum pulse rate		2.5 kHz	
★ VL-L is limited to 700 VAC (2) As per IEC 61557-12			

PM5350IB/PB series

Parts of PM5350IB and PM5350PB (rear panel door removed)

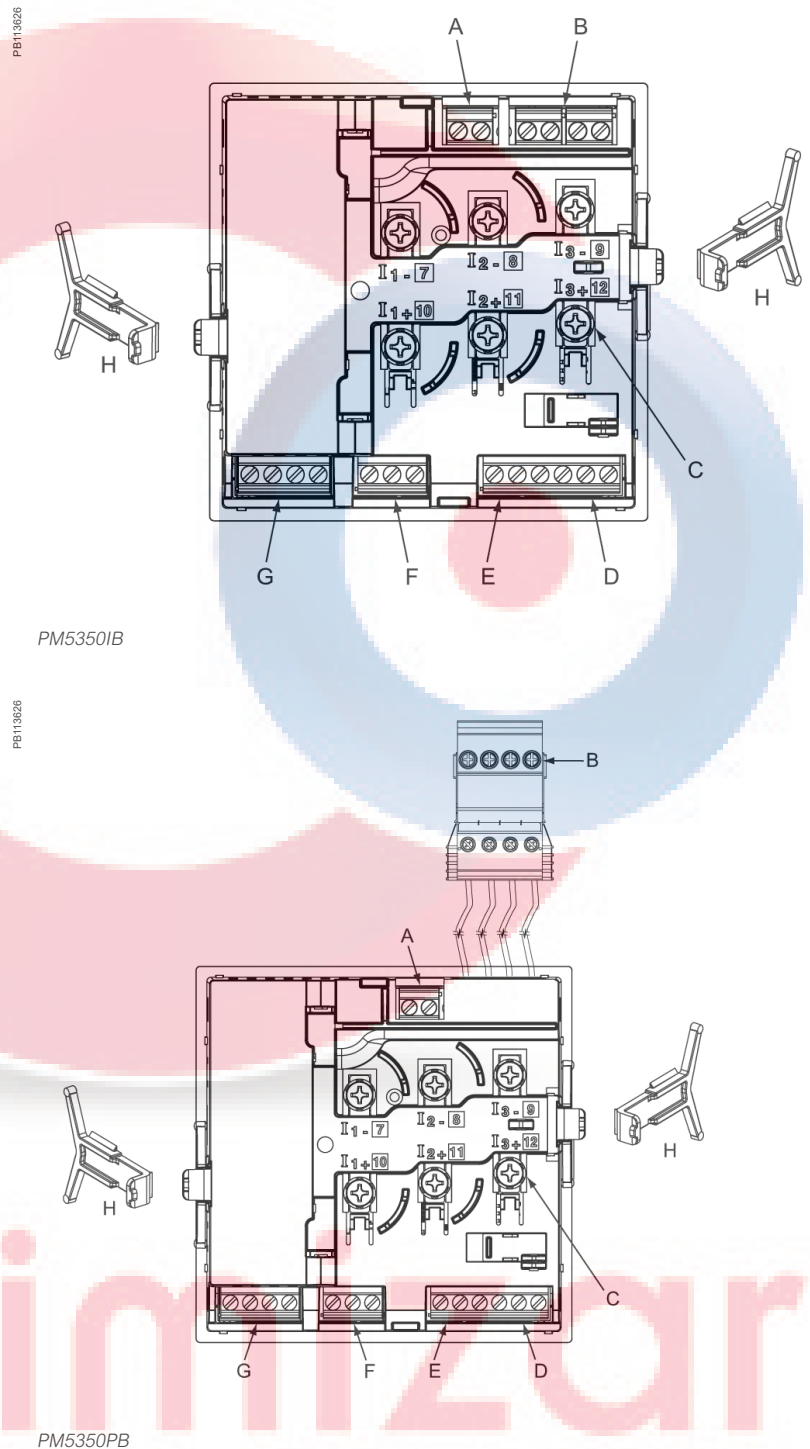

- | | |
|-------------------------|--|
| A Control power | E Wetting voltage source (for digital inputs) |
| B Voltage inputs | F RS-485 communications |
| C Current inputs | G Digital outputs |
| D Digital inputs | H Retainer clips |

PM5350IB/PB series

Installation

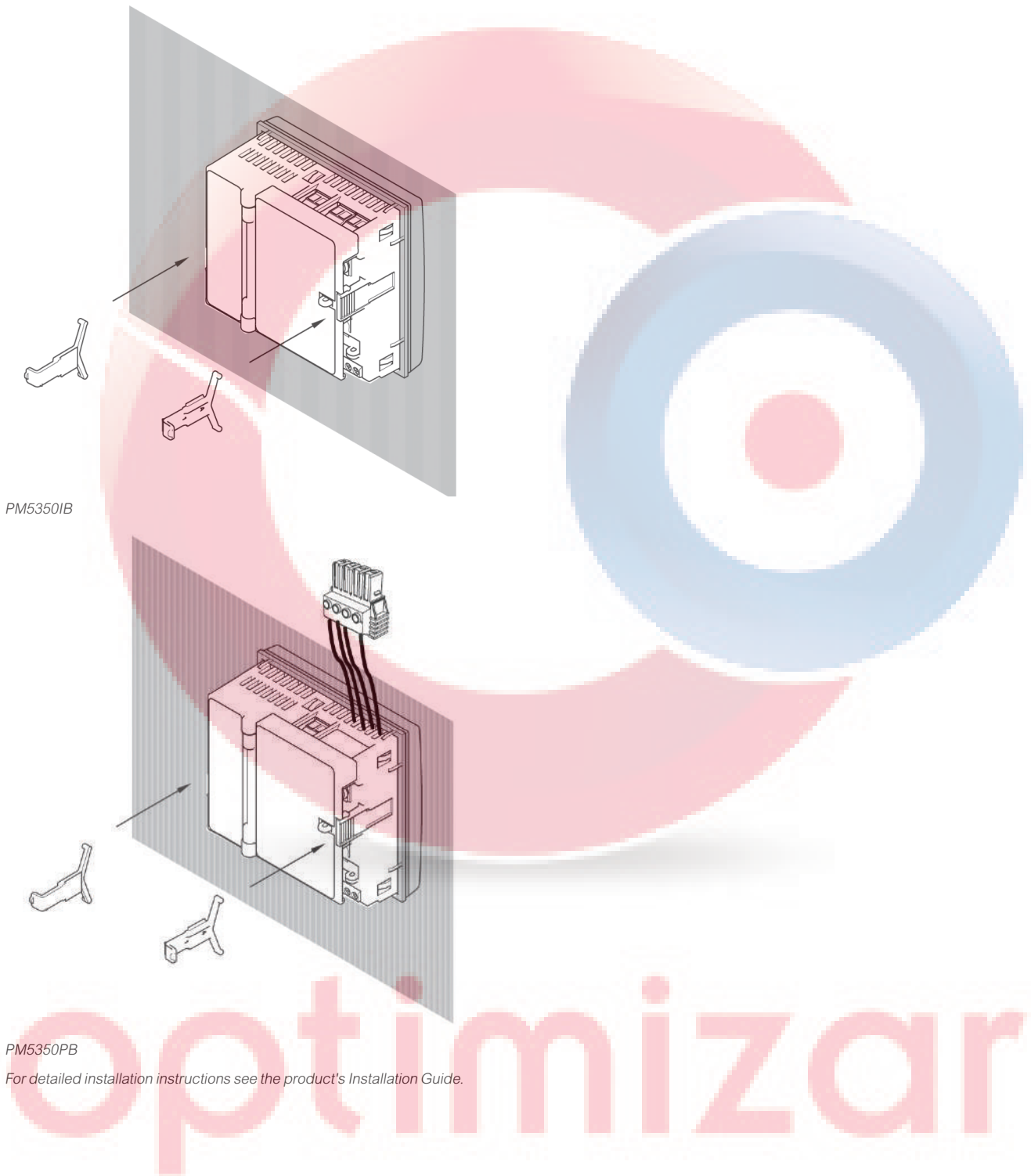

For detailed installation instructions see the product's Installation Guide.

PM5350P series

The PowerLogic PM5350P series power meters are the new benchmark in affordable, precision metering.

The PowerLogic PM5350P power meter offers all the measurement capabilities required to monitor an electrical installation in a space-efficient, single 96 x 96 mm unit.

Applications

- Panel instrumentation
- Cost allocation or energy management
- Electrical installation remote monitoring
- Sophisticated alarming
- Circuit Breaker monitoring and control

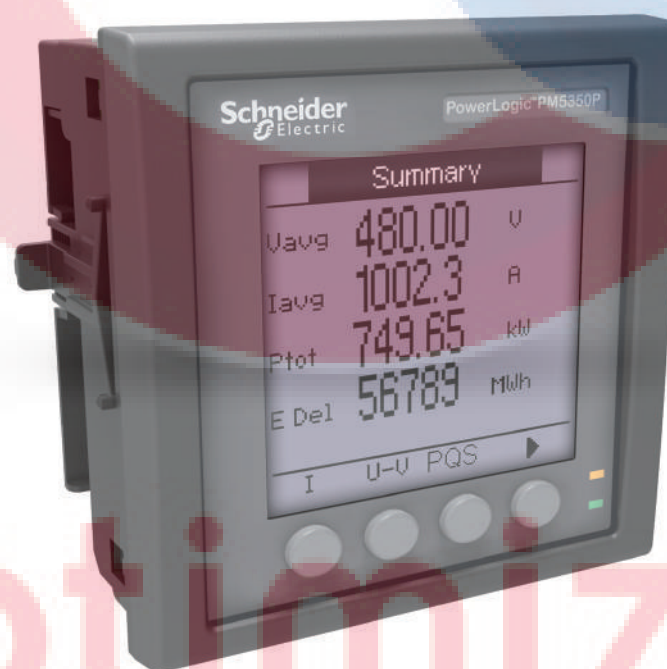

METSEPM5350P

PB117510

The solution for

Markets that can benefit from a solution that includes PowerLogic PM5350P series meters:

- Buildings
- Industry
- Healthcare
- Data Centre and networks
- Infrastructure

Benefits

System integrators' benefit

- Ease of integration
- Ease of setup
- Cost effectiveness

Panel builders' benefit

- Ease of installation
- Cost effectiveness
- Aesthetically pleasing
- Simplified ordering

End users' benefit

- Ease of use
- Precision metering & sub-billing
- Billing flexibility
- Comprehensive, consistent and superior performance

Competitive advantages

- Easy to install and operate
- Easy for circuit breaker monitoring and control
- Power quality analysis
- Load management combined with alarm and timestamping
- High performance and accuracy
- Multi-tariff capabilities
- Individual harmonics up to 31st

Power management solutions

Schneider Electric provides innovative power management solutions to increase your energy efficiency and cost savings, maximise electrical network reliability and availability, and optimise electrical asset performance.

Conformity of standards

- IEC 62053-22
- IEC 61326-1
- IEC 61557-12
- UL 61010-1
- IEC 62053-23
- IEC 61000-3-3
- IEC 61010-1

optimizer

PB17510



PowerLogic PM5350P

The PowerLogic PM5350P power meter offers electrical installation measurement capabilities in a single 96 x 96 mm unit. Three-phases and neutral can be monitored simultaneously using a bright, anti-glare display with large characters and backlighting. Menus are intuitive and the meter supports English, Chinese, Hebrew, and Spanish. Its compact size and high performance make the PowerLogic PM5350P suitable for many applications.

- Applications

- Panel instrumentation.
- Cost allocation or energy management.
- Electrical installation remote monitoring.
- Alarming with under/over, digital status, control power interruption, meter reset, self diagnostic issue.
- Circuit Breaker monitoring and control with relay outputs and whetted digital inputs.

- Main characteristics

- Easy to install
 - Mounts using two clips, no tools required. Ultra compact meter with 44 mm depth connectable up to 480 V L-L without voltage transformers for installations compliant with category III, as per IEC 61010-1. See specification table for UL voltage limits.
- Easy to operate
 - Intuitive navigation with self-guided, language selectable menus, six lines, four concurrent values. Two LEDs help confirm normal operation.
- Easy circuit breaker monitoring and control
 - Two relay outputs (high performance) to command most circuit breaker coils directly. Monitored switches can be wired directly without external power supply.
- System status at a glance
 - Bright, anti-glare, backlit display plus two LEDs; orange for energy pulse or alarm and green for heartbeat/communications indication.
- IEC 62053-22 class 0.5S accuracy for active energy
 - Accurate energy measurement for cost allocation.
- Power Quality analysis
 - The PM5350P offers THD and TDD measurements as standard. Total Demand Distortion is based on a point of common coupling (PCC), which is a common point that each user receives power from the power source. The TDD compares the contribution of harmonics versus the maximum demand load. In addition, it has individual harmonics (odd) measurement up to 31st harmonics. These types of power quality parameters help to identify the source of harmonics that can harm transformers, capacitors, generators, motors and electronic equipment.

- Load management

- Peak demands with Timestamping are provided. Predicted demand values can be used in basic load shedding applications. Alarming with timestamping
- Over 30 alarm conditions, such as under/over conditions, digital input changes, and phase unbalance inform you of events. A time-stamped log maintains a record of the last 40 alarm events.
- Load timer setpoint adjustable to monitor and advise maintenance requirements.
- Performance Standard Meets IEC 61557-12 PMD/Sx/K70/0.5.

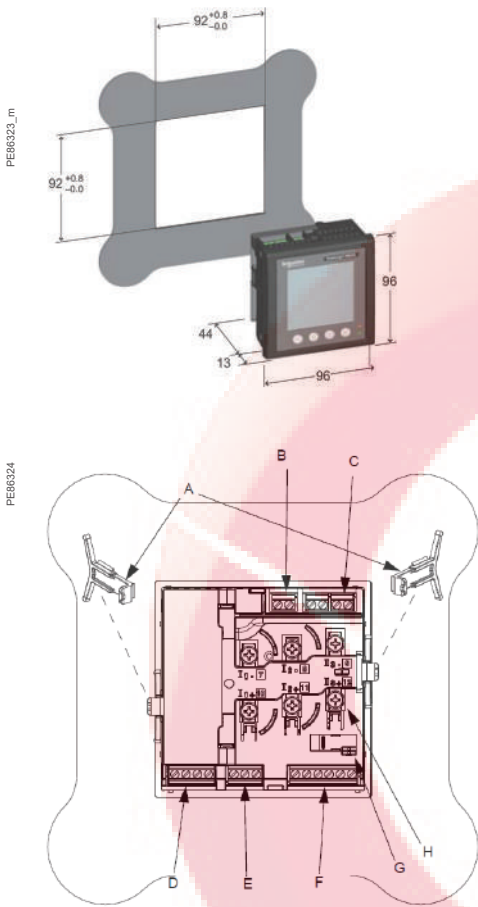

PM5350P meter parts

- A Retainer clips.
- B Control power supply connector.
- C Voltage inputs.
- D Digital outputs.
- E RS-485 port (COM1).
- F Digital inputs.
- G Optical revenue switch.
- H Current inputs.

Feature guide		PM5350P
General		
Use on LV and MV systems		■
Basic metering with THD and min/max readings		■
Instantaneous rms values		
Current	Total, Phases and neutral	■
Voltage	Total, Ph-Ph and Ph-N	■
Frequency		■
Real, reactive, and apparent power	Total and per phase	Signed
True Power Factor	Total and per phase	Signed, Four Quadrant
Displacement PF	Total and per phase	Signed, Four Quadrant
Unbalanced I, VL-N, VL-L		■
Energy values		Stored in non-volatile memory
Accumulated Active, Reactive and Apparent Energy		Received/Delivered; Net and absolute; ■
Demand values		
Current average		Present, Last, Predicted, Peak, & Peak Date Time ■
Active power		Present, Last, Predicted, Peak, & Peak Date Time ■
Reactive power		Present, Last, Predicted, Peak, & Peak Date Time ■
Apparent power		Present, Last, Predicted, Peak, & Peak Date Time ■
Multi-tariff		4 tariffs ■
Peak demand with timestamping D/T for current & powers		■ ■
Demand calculation	Sliding, fixed and rolling block, thermal	■ ■
Synchronization of the measurement window		■ ■
Other measurements		
I/O timer		■ ■
Operating timer		■ ■
Active load timer		■ ■
Alarm counters		■ ■
Power quality measurements		
THD, thd (Total Harmonic Distortion)		I, V L-N, V L-L
TDD, thd (Total Demand Distortion)		■
Harmonics Individual (Odd)		31st
Data recording		
Min/max of instantaneous values, plus phase identification		■ ■
Alarms with 1s timestamping		Standard 29; Unary 4; Digital 4
Alarms stored in non-volatile memory		40 events ■
Inputs/Outputs		
Digital inputs		4 (DI1, DI2, DI3, DI4)
Digital outputs		2 relay outputs (DO1, DO2)
Display		
White backlit LCD display, 6 lines, 4 concurrent values		■
IEC or IEEE visualization mode		■
Communication		
Modbus RTU, Modbus ASCII, Jbus Protocol		■
Firmware update via RS-485 serial port (DLF3000 via the Schneider Electric website: www.schneider-electric.com)		■

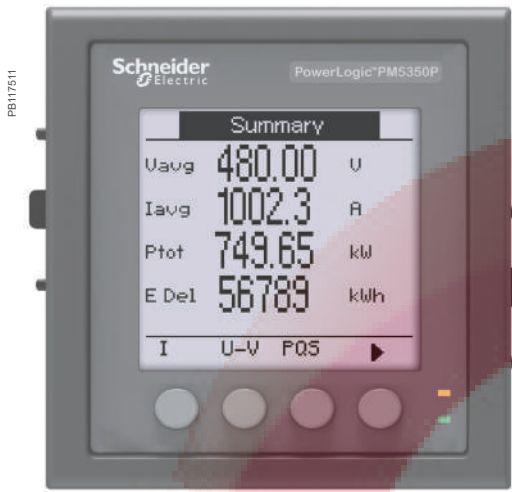

PowerLogic PM5350P front display

Electrical characteristics		
Type of measurement		RMS including harmonics upto 31st on three-phase AC system (3P, 3P + N) 64 samples per cycle, zero blind
Measurement accuracy	Active Energy	Class 0.5S as per IEC 62053-22 up to 9A Class 0.5 as per IEC 61557-12 up to 9A For 5 A nominal CT (for 1 A nominal CT when I > 0.15 A)
	Reactive Energy	Class 2 as per IEC 62053-23 up to 9 A Class 2 as per IEC 61557-12 up to 9 A For 5 A nominal CT (for 1 A nominal CT when I > 0.15 A)
	Active Power	Class 0.5 as per IEC 61557-12 upto 9A For 5 A nominal CT (for 1 A nominal CT when I > 0.15 A)
	Frequency★	±0.05 %
	Current, Phase★	±0.5 %
	Voltage, L-N★	±0.50 %
	Power Factor★	±0.01 Count
	Voltage Harmonics	Class 5 as per 61557-12 ★ ★
	Voltage THD/thd	Class 5 as per 61557-12 ★ ★
	Current Harmonics	Class 5 as per 61557-12 ★ ★
Current THD/ thd	Class 5 as per 61557-12 ★ ★	
★ Measurement applicable from 45 Hz to 65 Hz , 0.5 A to 9 A , 57 V to 347V and 0.5 Inductive , 0.5 capacitive power factor With a sinusoidal wave ★ ★ Accuracy applicable up to 15th Harmonics measured up to 31st Harmonics		
Data update rate		1 second nominal (50/60 cycles)
Input voltage	U nom	277 V L-N
	Measured voltage with overrange & Crest Factor	Per IEC 61010-1 CAT III, 20-277 V L-N / 20-480 V L-L CAT II, 20-400 V L-N / 20-690 V L-L Per UL 61010-1 and CSA C22.2 NO. 61010-1 CAT III, 20-300 V L-L AC
	Permanent overload	700 V AC L-L, 404 V AC L-N
	Impedance	5 MΩ
	Frequency range	45 to 65 Hz
Input-current	CT ratings Secondary	1 A, 5 A nominal
	Measured voltage with overrange & Crest Factor	5 mA to 9 A
	Withstand	Continuous 20 A, 10 sec/hr 50 A, 1 sec/hr 500 A
	Impedance	< 0.3 MΩ
	Frequency range	45 to 65 Hz
AC control power	Operating range	85 - 265 V AC
	Burden	7 VA / 4W maximum at 120 V AC, 9 VA / 5W maximum at 230 V AC, 11.9 VA /5W maximum at 265 V AC
	Frequency	45 to 65 Hz
	Ride-through time	40 mS typical at 120 V AC and maximum burden 250 mS typical at 230 V AC and maximum burden
DC control power	Operating range	100 to 300 V DC
	Burden	4 W maximum at 125 V DC, 5 W maximum at 250 V DC, 5 W maximum at 300 V DC
	Ride-through time	30 mS typical at 125 V DC and maximum burden
Real time clock	Clock drift	~0.5 seconds per day
	Battery Backup time	3 years without control power
Digital output	Number/Type	2 - Mechanical Relays
	Output frequency	0.5 Hz maximum (1 second ON / 1 second OFF - minimum times)
	Switching Current	250 V AC at 2.0 Amps, 200k cycles, resistive 250 V AC at 8.0 Amps, 25k cycles, resistive 250 V AC at 2.0 Amps, 50k cycles, COSΦ=0.4 30 V DC at 2.0 Amps, 75k cycles, resistive 30 V DC at 5.0 Amps, 12.5k cycles, resistive NOTE: The COSΦ ratings are not evaluated for UL
	Isolation	2.5 kVrms
	Status Digital Inputs	
Status Digital Inputs	Voltage ratings	ON 18.5 to 36 V DC, OFF 0 to 4 V DC
	Input Resistance	110 k Ω
	Maximum Frequency	2 Hz (T ON min = T OFF min = 250 ms)
	Response Time	10 ms
	Isolation	2.5 kVrms
Whetting output	Nominal voltage	24 V DC
	Allowable load	4 mA
	Isolation	2.5 kVrms

optimiser

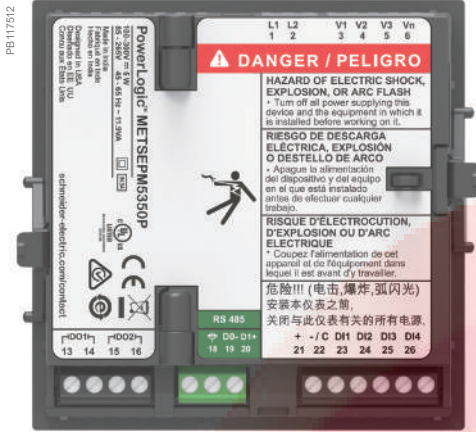

Rear view of PowerLogic PM5350P

Feature selection

Commercial reference number	Description
METSEPM5350	RS-485 Modbus, THD, 4DI, 2Relay
METSEPM5350IB	RS-485, 4DI/2Relay, Multi-level alarm, UL480V, 4DI/2Relay
METSEPM5350PB	RS-485, 4DI/2Relay, Multi-level alarm, UL300V, 4DI/2Relay
METSEPM5350P	RS-485 Modbus, THD, Multi-tariff and individual harmonics 4DI/2relay
METSEPM5100	No communication, 1DO
METSEPM5110	RS-485 Modbus, 1DO
METSEPM5111	RS-485 ModBus, 1DO, MID certified
METSEPM5310	RS-485 Modbus, 2DI/2DO
METSEPM5320	Ethernet 2DI/2DO
METSEPM5330	RS-485 Modbus, 2DI/2DO, 2Relay
METSEPM5331	RS-485 Modbus, 2DI/2DO, 2Relay, MID certified
METSEPM5340	Ethernet 2DI/2DO, 2Relay
METSEPM5341	Ethernet 2DI/2DO, 2Relay, MID certified
METSEPM5560	Modbus and Ethernet, 4DI/2DO
METSEPM5561	Modbus and Ethernet, MID certified
METSEPM5562	RMICAN approved, HW lockable, 4DI/2DO
METSEPM5562MC	RMICAN approved, factory sealed, 4DI/2DO
METSEPM5563	DIN mount , no display Power meter, 4DI/2DO
METSEPM5563RD	Remote Display for PM5563

Mechanical characteristics		
Weight		250 g
IP degree of protection (IEC 60529)		Designed to IP51 front display, IP30 meter body (Excluding connectors)
Dimensions	W x H x D	96 x 96 x 44 mm (depth of meter from housing mounting flange) 96 x 96 x 13 mm (protrusion of meter from housing flange)
Mounting position		Vertical
Panel thickness		6.35 mm max

Environmental characteristics		
Operating temperature	Meter	-25 °C to 70 °C
	Display	-20 °C to 70 °C (Display functions to -25 °C with reduced performance)
Storage temp.	Meter + display	-40 °C to 85 °C
Humidity rating		5 % to 95 % RH at 50 °C (non-condensing)
Pollution degree		2
Altitude		≤ 3000 m max
Indoor use only	Not suitable for wet locations	

Electromagnetic compatibility		
Electrostatic discharge		IEC 61000-4-2★
Immunity to radiated fields		IEC 61000-4-3★
Immunity to fast transients		IEC 61000-4-4★
Immunity to impulse waves		IEC 61000-4-5★
Conducted immunity		IEC 61000-4-6★
Immunity to magnetic fields		IEC 61000-4-8★
Immunity to voltage dips		IEC 61000-4-11★
Radiated emissions		FCC part 15 class A, EN 55011 class A
Conducted emissions		FCC part 15 class A, EN 55011 class A
Harmonics		IEC 61000-3-2★
Flicker emissions		IEC 61000-3-3★

Safety		
Europe		CE, as per IEC 61010-1 3rd Edition
U.S. and Canada		UL 61010-1 and CAN/CSA-C22.2 No. 61010, 3rd Edition

Measurement category (Voltage inputs)		Per IEC 61010-1 CAT III, 20-277 V L-N / 20-480 V L-L CAT II, 20-400 V L-N / 20-690 V L-L Per UL 61010-1 and CSA C22.2 NO. 61010-1 CAT III, 20-300 V L-L
Current Inputs (sensor connected)		Require external Current Transformer for Insulation
Overvoltage Category (Control power)		CAT III
Overvoltage Category (Relay)		CAT II
Dielectric withstand		As per IEC 61010-1 Double insulated front panel display
Protective Class		Class II
Double insulation at user-accessible area		Included

Communication		
RS-485 port		2-Wire, 9600, 19200 or 38400 baud, Parity - Even, Odd, None, 1 stop bit if parity Odd or Even, 2 stop bits if None; Modbus RTU, Modbus ASCII (7 or 8 bit), JBUS
Firmware and language file update		Update via communication port using DLF3000 software
Isolation		2.5 kVrms

Human machine interface		
Display type		Monochrome Graphics LCD
Resolution		128 x 128
Backlight		White LED
Viewable area (W x H)		67 x 62.5 mm
Keypad type		4-button
Indicator Heartbeat / Comm activity		Green LED

Energy pulse output / Active alarm indication (configurable)		
Type		Optical, amber LED
Wavelength		590 to 635 nm
Maximum pulse rate		2.5 kHz

Rear of meter - open

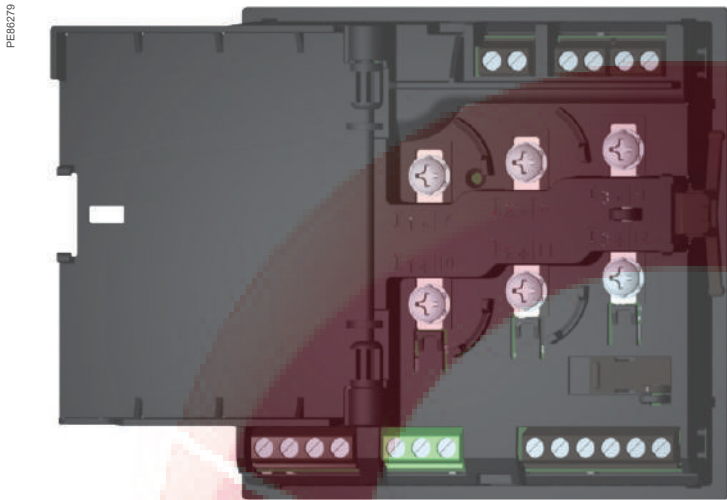

Rear view retainers - installation

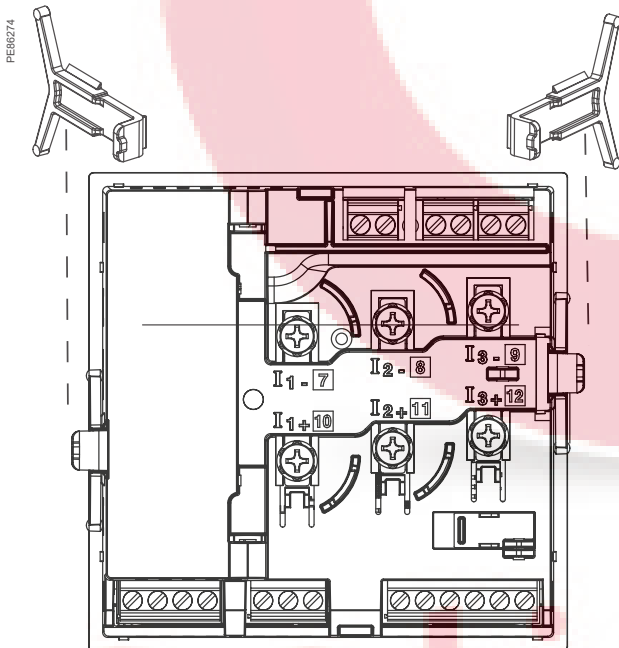

Rear view retainers - users

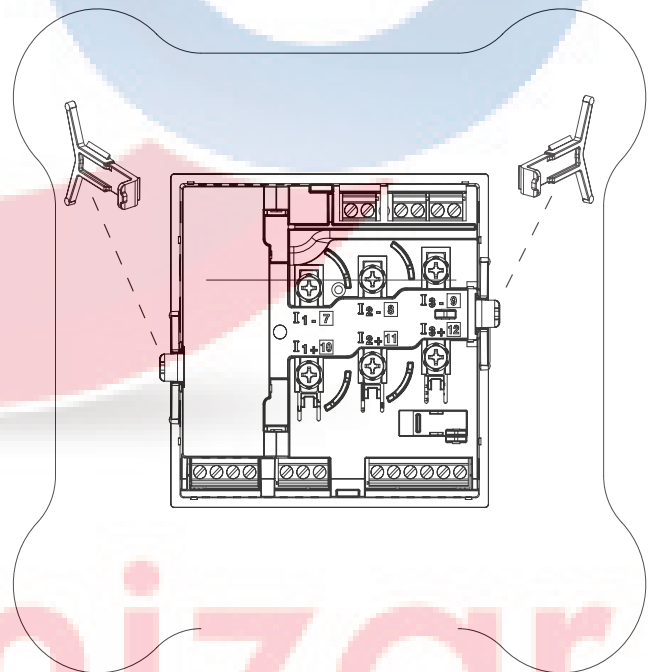

For detailed installation instructions see the product's Installation Guide.

PM5000 series

The PowerLogic PM5000 series power meters are the new benchmark in affordable, precision metering.

The value you want, the precision you need. Compact, affordable power meters with high-end cost capabilities and basic mobile energy management.

Applications

Capable of essential cost management:

- Sub-billing/tenant metering
- Equipment sub-billing
- Energy cost allocation

Also ideal for electrical network management:

- Track real-time power conditions
- Monitor control functions
- Provide basic power quality values
- Monitor equipment and network status
- BACnet/IP, Ethernet/IP, and DNP3.0 protocol support

PB118061

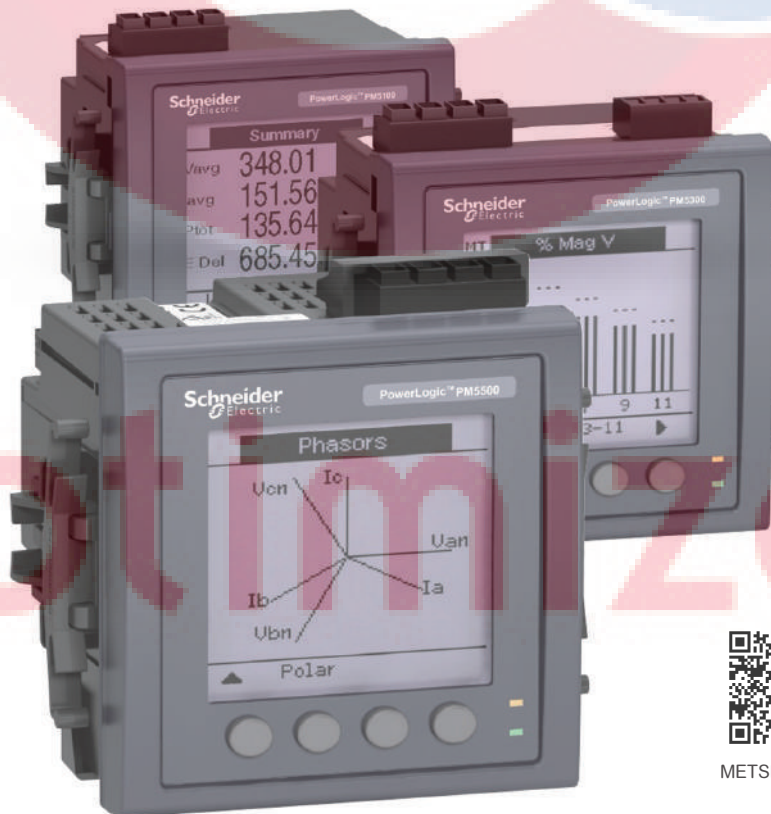

METSEPM5100

The solution for

Markets that can benefit from a solution that includes PowerLogic PM5000 series meters:

- Buildings
- Industry
- Healthcare
- Data Center and networks
- Infrastructure

Benefits

System integrators' benefit

- Ease of integration
- Ease of setup
- Cost effectiveness

Panel builders' benefit

- Ease of installation
- Cost effectiveness
- Aesthetically pleasing
- Simplified ordering

End users' benefit

- Ease of use
- Precision metering & sub-billing
- Billing flexibility
- Comprehensive, consistent and superior performance

Competitive advantages

- Easy to install and operate
- Easy for circuit breaker monitoring and control
- Power quality analysis
- Load management combined with alarm and timestamping
- High performance and accuracy
- MID ready compliance for legal billing application
- BACnet/IP, Ethernet/IP, and DNP3.0 protocol support

Power management solutions

Schneider Electric provides innovative power management solutions to increase your energy efficiency and cost savings, maximize electrical network reliability and availability, and optimize electrical asset performance.

Conformity of standards

- IEC 61557-12
- IEC 62053-22
- IEC 62053-24
- IEEE 802.3
- EN 50470-1
- EN 50470-3
- IEC 61010-1
- IEC 61326-1
- CISPR22 Class B
- ODVA certification
- ANSI C12.1-2008 (PM55xx)
- ANSI C12.20-210 0.2 & 0.5 (PM55xx)



PM5000 series

PM5000 series feature selection												
	PM5100		PM5300						PM5500			PM5600
	PM5100	PM5110	PM5310	PM5310R	PM5320	PM5320R	PM5330	PM5340	PM5560	PM5563	PM5563RD	PM5650
Installation												
Fast installation, panel mount with integrated display	■	■	■	■	■	■	■	■	■	-	-	■
Fast installation, DIN rail mountable	-	-	-	-	-	-	-	-	-	■	■	-
Accuracy	CL 0.5S	CL 0.5S	CL 0.5S	CL 0.5S	CL 0.5S	CL 0.5S	CL 0.5S	CL 0.5S	CL 0.2S	CL 0.2S	CL 0.2S	CL 0.2S
Display												
Backlit LCD, multilingual, bar graphs, 6 lines, 4 concurrent values	■	■	■	■	■	■	■	■	■	■	■	■
Power and energy metering												
3-ph voltage, current, power, demand, energy, frequency, power factor	■	■	■	■	■	■	■	■	■	■	■	■
Multi-tariff	-	-	4	4	4	4	4	4	8	8	8	8
Power quality analysis												
THD, thd, TDD	■	■	■	■	■	■	■	■	■	■	■	■
Harmonics, individual (odd) up to	15th	15th	31st	31st	31st	31st	31st	31st	63rd	63rd	63rd	63rd
Waveform capture & sag/swell detection	-	-	-	-	-	-	-	-	-	-	-	8 cycles @ 128 cycles/sec
I/Os and relays												
I/Os	1DO	1DO	2DI/2DO	2DI/2DO	2DI/2DO	2DI/2DO	2DI/2DO	2DI/2DO	4DI/2DO	4DI/2DO	4DI/2DO	4DI/2DO
Relays	0	0	0	0	0	0	2	2	0	0	0	0
Alarms and control												
Alarms	33	33	35	35	35	35	35	35	52	52	52	52
Set point response time, seconds	1	1	1	1	1	1	1	1	1	1	1	1
Single and multi-condition alarms	-	-	■	■	■	■	■	■	■	■	■	■
Boolean alarm logic	-	-	-	-	-	-	-	-	■	■	■	■
Memory for data logging	-	-	256KB	256KB	256KB	256KB	256KB	256KB	1.1 MB	1.1 MB	1.1 MB	1.1 MB
Communications												
Serial ports with modbus protocol	-	1	1	1	-	-	1	-	1	1	1	1
Ethernet port with Modbus TCP protocol	-	-	-	-	1	1	-	1	2★	2★	2★	2★
BACnet/IP protocol	-	-	-	-	■	■	-	■	■	■	■	■
Ethernet/IP protocol	-	-	-	-	-	-	-	-	■	■	■	■
DNP3.0 over Ethernet	-	-	-	-	-	-	-	-	■	■	■	■
Onboard web server with web pages	-	-	-	-	-	-	-	-	■	■	■	■
Serial to Ethernet gateway	-	-	-	-	-	-	-	-	■	■	■	■
MID ready compliance, EN50470-1/3, Annex B & Annex D Class C	-	PM5111	-	-	-	-	PM5331	PM5341	PM5561	-	-	-
Short ref. numbers	PM5100	PM5110	PM5310	PM5310R	PM5320	PM5320R	PM5330	PM5340	PM5560	PM5563	PM5563RD	PM5650

(See table below for complete commercial reference numbers)

★ 2 Ethernet ports for daisy chain, one IP address. NOTE: PM5310R and PM5320R must be used with Schneider Electric's "Quick Click" 3-in-1 LVCTs

PM5000 series

PM5000 technical specifications		PM5100	PM5300	PM5500	PM5600
Use on LV and MV systems				■	
Basic metering with THD and min/max readings				■	
Instantaneous rms values					
Current	per phase, neutral and ground (PM5500)			■	
Voltage	Total, per phase L-L and L-N			■	
Frequency				■	
Real, reactive, and apparent power	Total and per phase			Signed, Four Quadrant	
True Power Factor	Total and per phase			Signed, Four Quadrant	
Displacement PF	Total and per phase			Signed, Four Quadrant	
% Unbalanced I, V L-N, V L-L				■	
Direct monitoring of neutral current					■
Energy values					
Accumulated Active, Reactive and Apparent Energy		Received/Delivered; Net and absolute; Time Counters			
Demand value					
Current average			Present, Last, Predicted, Peak, and Peak Date Time		
Active power			Present, Last, Predicted, Peak, and Peak Date Time		
Reactive power			Present, Last, Predicted, Peak, and Peak Date Time		
Apparent power			Present, Last, Predicted, Peak, and Peak Date Time		
Peak demand with timestamping D/T for current and powers				■	
Demand calculation	Sliding, fixed and rolling block, thermal methods			■	
Synchronisation of the measurement window to input, communication command or internal clock				■	
Settable Demand intervals				■	
Demand calculation for Pulse input (WAGES)					■
Other measurements					
I/O timer				■	
Operating timer				■	
Load timer				■	
Alarm counters and alarm logs				■	
Power quality measurements					
THD, thd (Total Harmonic Distortion) I, VLN, VLL				I, VLN, VLL	
TDD (Total Demand Distortion)				■	
Individual harmonics (odds)		15th	31st		63rd
Neutral Current metering with ground current calculation					■
Waveform capture and sag/swell detection					8 cycles @ 128 cycles/sec
Data recording					
Min/max of instantaneous values, plus phase identification★				■	
Alarms with 1s timestamping★				■	
Data logging			2 fixed parameters kWh and kVAh with configurable interval and duration (e.g. 2 parameters for 60 days at 15 minutes interval)	Up to 14 selectable parameters with configurable interval and duration (e.g. 6 parameters for 90 days at 15 minutes interval)	
Memory capacity			256 kB	1.1 MB	
Min/max log		■	■	■	
Maintenance, alarm and event logs			■	■	
Customisable data logs				■	

★ Stored in non-volatile memory

PM5000 series

PM5000 technical specifications

		PM5100	PM5300	PM5500	PM5600
Inputs / Outputs / Mechanical Relays					
Digital inputs			2 (SI1, SI2)	4 (SI1, SI2, SI3, SI4) with WAGES support	
Digital outputs		1 (kWh only)	2 (configurable)	2 (configurable)	
Form A Relay outputs			2		
Timestamp resolution in seconds		1	1	1	1
Whetting voltage			■		
Type of measurement: True rms on three-phase (3P, 3P + N)		64 samples per cycle		128 samples per cycle	
Measurement accuracy	IEC 61557-12	PMD/[SD SS]/K70/0.5		PMD/[SD SS]/K70/0.2	
	Active Energy	Class 0.5S as per IEC 62053-22		Class 0.2S as per IEC 62053-22	
	Reactive Energy	Class 2S as per IEC 62053-24		Class 2S as per IEC 62053-24	
	Active Energy	±0.5 %		±0.2 %	
	Reactive Energy	±2 %		±1 %	
	Active Power	Class 0.5 as per IEC 61557-12		Class 0.2 as per IEC 61557-12	
	Apparent Power	Class 0.5 as per IEC 61557-12			
	Current, Phase	Class 0.5 as per IEC 61557-12		±0.15 %	
	Voltage, L-N	Class 0.5 as per IEC 61557-12		±0.1 %	
	Frequency	±0.05 %			
	MID Directive EN50470-1, EN50470-3	Annex B and Annex D (Optional model references) Class C			
Input-voltage (up to 1.0 MV AC max, with voltage transformer)	Nominal Measured Voltage range	20 V L-N / 35 V L-L to 400 V L-N /690 V L-L absolute range 35 V L-L to 760 V L-L		20 V L-N / 20 V L-L to 400 V L-N /690 V L-L absolute range 20 V L-L to 828 V L-L	
	Impedance	5 MΩ			
	F nom	50 or 60 Hz ±5 %		50 or 60 Hz ±10 %	
Input-current (configurable for 1 or 5 A secondary CTs)	I nom	5 A			
	Measured Amps with over range and Crest Factor	Starting current: 5 mA Operating range: 50 mA to 8.5 A		Starting current: 5 mA Operating range: 50 mA to 10 A	
	Withstand	Continuous 20 A, 10 s/hr 50 A, 1s/hr 500 A			
	Impedance	< 0.3 mΩ			
	F nom	50 or 60 Hz ±5 %		50 or 60 Hz ±10 %	
	Burden	<0.026 VA at 8.5 A			
AC control power	Operating range	100 - 277 V AC L-N / 415 V L-L +/-10 % CAT III 300V class per IEC 61010		100-480 V AC ±10 % CAT III 600V class per IEC 61010	
	Burden	<5W,11 VA at 415V L-L		<5W/16.0 VA at 480 V AC	
	Frequency	45 to 65 Hz			
	Ride-through time	80 mS typical at 120V AC and maximum burden. 100 mS typical at 230 V AC and maximum burden 100 mS typical at 415 V AC and maximum burden		35 ms typical at 120 V L-N and maximum burden 129 ms typical at 230 V L-N and maximum burden	
DC control power	Operating range	125-250 V DC ±20 %			
	Burden	<4 W at 250 V DC		typical 3.1W at 125 V DC, max. 5W	
	Ride-through time	50 mS typical at 125 V DC and maximum burden			

PM5000 series

PM5000 technical specifications

		PM5100	PM5300	PM5500	PM5600
Relay	Max output frequency		0.5 Hz maximum (1 second ON / 1 second OFF - min times)		
	Switching current		250 V AC at 8.0 Amps, 25 k cycles, resistive 30 V DC at 2.0 Amps, 75 k cycles, resistive 30 V DC at 5.0 Amps, 12.5 k cycles, resistive		
	Isolation		2.5 kV rms		
Outputs	Digital outputs	1	2	2	2
	Max load voltage	40 V DC		30 V AC / 60 V DC	
	Max load current	20 mA		125 mA	
	On Resistance	50 Ω max		8 Ω	
	Meter constant	from 1 to 9,999,999 pulses per kWh			
	Pulse width for Digital Output	50 % duty cycle			
	Pulse frequency for Digital Output	25 Hz max.			
	Leakage current	0.03 micro Amps		1 micro Amps	
	Isolation	5 kV rms		2.5 kV rms	
	Optical outputs	Pulse width (LED)	200 ms		
Pulse frequency		50 Hz. max.		2.5 kHz. max	
Meter constant		from 1 to 9,999,999 pulses per k_h			
Status Inputs	ON Voltage		18.5 to 36 V DC	30 V AC / 60 V DC max	
	OFF Voltage			0 to 4 V DC	
	Input Resistance		110 k Ω	100 k Ω	
	Maximum Frequency		2 Hz (T ON min = T OFF min = 250 ms)	25 Hz (T ON min = T OFF min = 20 ms)	
	Response Time		20 ms	10 ms	
	Opto Isolation		5 kV rms	2.5 kV rms	
	Wetting output		24 V DC/ 8 mA max		
	Input Burden		2mA @24V DC	2 mA @ 24 V AC/DC	
Mechanical characteristics					
Product weight		380 g	430 g	450 g	450 g
IP degree of protection (IEC 60529)		IP52 front display, (IP54 for PM53xx and PM55xx), IP30 meter body			
Dimensions W x H x D [protrusion from cabinet]		96 x 96 x 72 mm (77 mm for PM5500) (depth of meter from housing mounting flange) [13 mm]			
Mounting position		Vertical			
Panel thickness		6 mm maximum			
Environmental characteristics					
Meter		-25 °C to 70 °C			
Display (Display functions to -25° with reduced performance)		-25 °C to 70 °C			
Storage temp.		-40 °C to 85 °C			
Humidity range		5 to 95 % RH at 50 °C (non-condensing)			
Polution degree		2			

PM5000 technical specifications

Electromagnetic compatibility				
Harmonic current emissions				IEC 61000-3-2
Flicker emissions				IEC 61000-3-3
Electrostatic discharge				IEC 61000-4-2
Immunity to radiated fields				IEC 61000-4-3
Immunity to fast transients				IEC 61000-4-4
Immunity to surge				IEC 61000-4-5
Conducted immunity 150 kHz to 80 MHz				IEC 61000-4-6
Immunity to magnetic fields				IEC 61000-4-8
Immunity to voltage dips				IEC 61000-4-11
Radiated emissions				FCC part 15, EN 55022 Class B
Conducted emissions				FCC part 15, EN 55022 Class B
Safety	PM5100	PM5300	PM5500	PM5600
Europe	CE, as per IEC 61010-1 Ed. 3, IEC 62052-11 & IEC 61557-12			
U.S. and Canada	cULus as per UL 61010-1 (3rd Edition)			
Measurement category (Voltage & Current inputs)	CAT III up to 400 V L-N / 690 V L-L			
Dielectric	As per IEC/UL 61010-1 Ed. 3			
Protective Class	II, Double insulated for user accessible parts			
Communication				
RS-485 port Modbus RTU, Modbus ASCII	2-Wire, 9600, 19200 or 38400 baud, Parity - Even, Odd, None, 1 stop bit if parity Odd or Even, 2 stop bits if None;			
Ethernet port: 10/100 Mbps; Modbus TCP/IP		1 Optional	2 (daisy chain only, 1 IP address)	
Native Ethernet/IP & DNP3.0 over Ethernet			Yes	Yes
Native BACnet/IP Support		Yes	Yes	Yes
Firmware and language file update	Meter firmware update via the communication ports			
Isolation	2.5 kVrms, double insulated			
Human machine interface				
Display type	Monochrome Graphics LCD			
Resolution	128 x 128			
Backlight	White LED			
Viewable area (W x H)	67 x 62.5 mm			
Keypad	4-button			
Indicator Heartbeat / Comm activity	Green LED			
Energy pulse output / Active alarm (configurable)	Optical, amber LED			
Wavelength	590 to 635 nm			
Maximum pulse rate	2.5 kHz			
Comm ref numbers	Description			
METSEPM5100	Power Meter range 72 mm depth, control power to 415 V AC, CI 0.5S, 15th harmonic, no communication, 1DO			
METSEPM5110	Power Meter range 72 mm depth, control power to 415 V AC, CI 0.5S, 15th harmonic, RS-485 Modbus, 1DO			
METSEPM5111	Power Meter range 72 mm depth, control power to 415 V AC, CI 0.5S, 15th harmonic, RS-485 Modbus, 1DO, MID cert.			
METSEPM5310	Power Meter range 72 mm depth, control power to 415 V AC, CI 0.5S, 31st harmonic, 256 kB, RS-485 Modbus, 2DI/2DO			
METSEPM5310R	Power Meter range 72 mm depth, control power to 415 V AC, CI 0.5S, 31st harmonic, 256 kB, RJ45 LVCT, RS-485 Modbus, 2DI/2DO			
METSEPM5320	Power Meter range 72 mm depth, control power to 415 V AC, CI 0.5S, 31st harmonic, 256 kB, Ethernet, 2DI/2DO			
METSEPM5320R	Power Meter range 72 mm depth, control power to 415 V AC, CI 0.5S, 31st harmonic, 256 kB, RJ45 LVCT, Ethernet, 2DI/2DO			
METSEPM5330	Power Meter range 72 mm depth, control power to 415 V AC, CI 0.5S, 31st harmonic, 256 kB, RS-485 Modbus, 2DI/2DO, 2Relay			
METSEPM5331	Power Meter range 72 mm depth, control power to 415 V AC, CI 0.5S, 31st harmonic, 256 kB, RS-485 Modbus, 2DI/2DO, 2Relay, MID cert.			
METSEPM5340	Power Meter range 72 mm depth, control power to 415 V AC, CI 0.5S, 31st harmonic, 256 kB, Ethernet, 2DI/2DO, 2Relay			
METSEPM5341	Power Meter range 72 mm depth, control power to 415 V AC, CI 0.5S, 31st harmonic, 256 kB, Ethernet, 2DI/2DO, 2Relay, MID cert.			
METSEPM5560	Power Meter range 77 mm depth, control power to 480 V AC, CI 0.2S, 63rd harmonic, 1.1 MB, Modbus and Ethernet, 4DI/2DO			
METSEPM5561	Power Meter range 77 mm depth, control power to 480 V AC, CI 0.2S, 63rd harmonic, 1.1 MB, Modbus and Ethernet, MID cert.			
METSEPM5562	Power Meter range 77 mm depth, control power to 480 V AC, CI 0.2S, 63rd harmonic, 1.1 MB, RMICAN approved, HW lockable, 4DI/2DO			
METSEPM5562MC	Power Meter range 77 mm depth, control power to 480 V AC, CI 0.2S, 63rd harmonic, 1.1 MB, RMICAN approved, factory sealed, 4DI/2DO			
METSEPM5563	Power Meter range 77 mm depth, control power to 480 V AC, CI 0.2S, 63rd harmonic, 1.1 MB, DIN mount, no display, 4DI/2DO			
METSEPM5563RD	Power Meter range 77 mm depth, control power to 480 V AC, CI 0.2S, 63rd harmonic, 1.1 MB, DIN mount, remote display, 4DI/2DO			
METSEPM5650	Power Meter range 77 mm depth, control power to 480 V AC, CI 0.2S, 63rd harmonic, waveform capture and sag/swell, 1.1 MB, Modbus and Ethernet, 4DI/2DO			

PM5xxR series commercial reference numbers

Comm. reference number	Description
0.333V 3-in-1 CTs with RJ45 for PM53x0R	
METSECTV25006	LVCT SolidC 3in1 RJ45 25mmCtr 60A:1/3V
METSECTV25010	LVCT SolidC 3in1 RJ45 25mmCtr 100A:1/3V
METSECTV25013	LVCT SolidC 3in1 RJ45 25mmCtr 125A:1/3V
METSECTV25016	LVCT SolidC 3in1 RJ45 25mmCtr 160A:1/3V
METSECTV35006	LVCT SolidC 3in1 RJ45 35mmCtr 60A:1/3V
METSECTV35010	LVCT SolidC 3in1 RJ45 35mmCtr 100A:1/3V
METSECTV35012	LVCT SolidC 3in1 RJ45 35mmCtr 120A:1/3V
METSECTV35013	LVCT SolidC 3in1 RJ45 35mmCtr 125A:1/3V
METSECTV35015	LVCT SolidC 3in1 RJ45 35mmCtr 150A:1/3V
METSECTV35016	LVCT SolidC 3in1 RJ45 35mmCtr 160A:1/3V
METSECTV35020	LVCT SolidC 3in1 RJ45 35mmCtr 200A:1/3V
METSECTV35025	LVCT SolidC 3in1 RJ45 35mmCtr 250A:1/3V
METSECTV45025	LVCT SolidC 3in1 RJ45 45mmCtr 250A:1/3V
METSECTV45030	LVCT SolidC 3in1 RJ45 45mmCtr 300A:1/3V
METSECTV45040	LVCT SolidC 3in1 RJ45 45mmCtr 400A:1/3V
METSECTV45050	LVCT SolidC 3in1 RJ45 45mmCtr 500A:1/3V
METSECTV45060	LVCT SolidC 3in1 RJ45 45mmCtr 600A:1/3V
METSECTV45063	LVCT SolidC 3in1 RJ45 45mmCtr 630A:1/3V
METSECTV29006	LVCT SolidC 3in1 RJ45 29mmCtr 60A:1/3V
METSECTV29010	LVCT SolidC 3in1 RJ45 29mmCtr 100A:1/3V
METSECTV29012	LVCT SolidC 3in1 RJ45 29mmCtr 120A:1/3V
METSECTV29013	LVCT SolidC 3in1 RJ45 29mmCtr 125A:1/3V
METSECTV29015	LVCT SolidC 3in1 RJ45 29mmCtr 150A:1/3V
METSECTV29016	LVCT SolidC 3in1 RJ45 29mmCtr 160A:1/3V
METSECTV29020	LVCT SolidC 3in1 RJ45 29mmCtr 200A:1/3V
METSECTV70080	LVCT SolidC 3in1 RJ45 70mmCtr 800A:1/3V
METSECTV70100	LVCT SolidC 3in1 RJ45 70mmCtr 1000A:1/3V
METSECTV70125	LVCT SolidC 3in1 RJ45 70mmCtr 1250A:1/3V
Cables	
DCEPCURJX5GYM	Category 5e, Patch Cord, UTP, 0.5 M, Grey
DCEPCURJ01GYM	Category 5e, Patch Cord, UTP, 1 M, Grey
DCEPCURJ02GYM	Category 5e, Patch Cord, UTP, 2 M, Grey
DCEPCURJ03GYM	Category 5e, Patch Cord, UTP, 3 M, Grey
DCEPCURJ05GYM	Category 5e, Patch Cord, UTP, 5 M, Grey
DCEPCURJ10GYM	Category 5e, Patch Cord, UTP, 10 M, Grey
Other related products	
METSEPM5RD	Remote display for PM5563
METSEPM51HK	Hardware kit for PM51xx
METSEPM53HK	Hardware kit for PM53xx
METSEPM51_3RSK	Revenue sealing kit for PM51XX & PM53XX
METSEPM55RSK	Revenue sealing kit for PM55XX
METSEPM55HK	Hardware kit for PM55xx
METSEPM5CAB3	Remote Display cable

See your Schneider Electric representative for complete ordering information.

PM5000 Series meter flush mounting

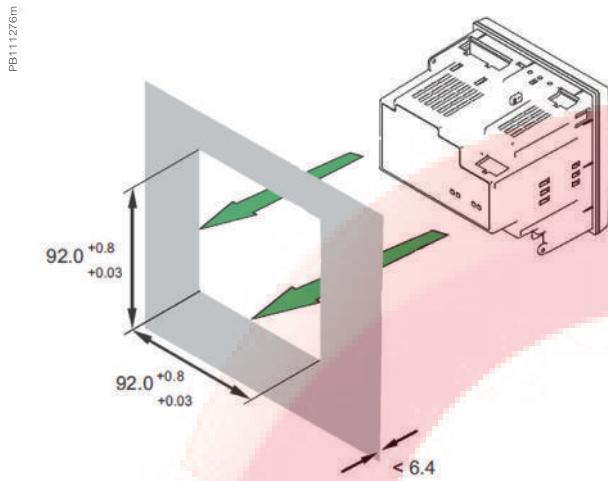

PM5000 series meter dimensions

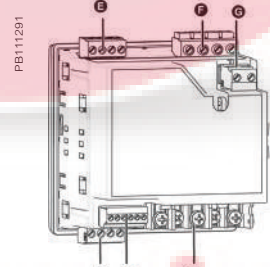
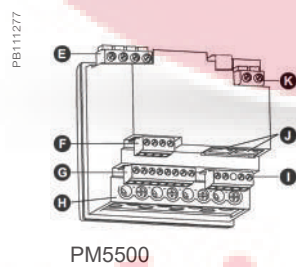
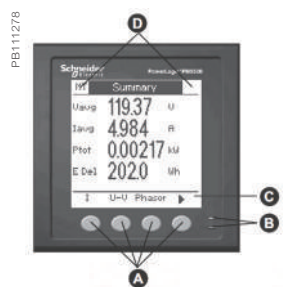
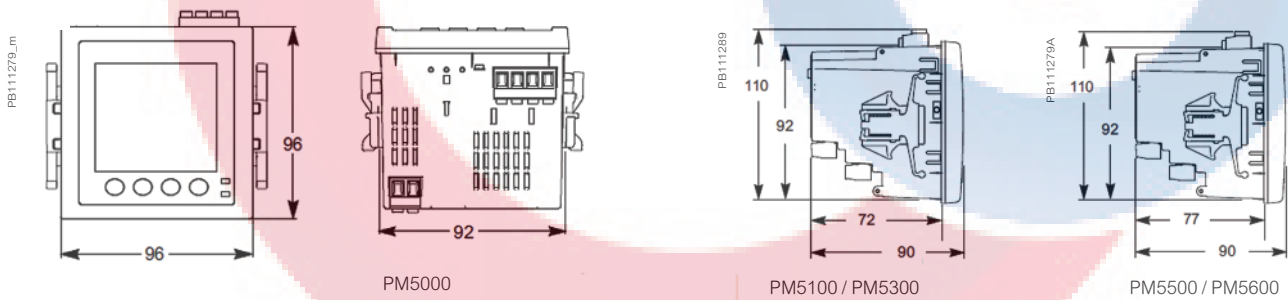

PM5000 meter parts

- A Menu selection buttons
- B LED indicators
- C Navigation or menu selections
- D Maintenance and alarm notification area

PM5500 / PM5600 meter parts

- E Voltage inputs
- F RS-485 comms
- G Digital inputs
- H Current inputs
- I Digital outputs
- J Ethernet ports
- K Control power

PM5100 / PM5300 meter parts

- E Relay output (PM5300 only)
- F Voltage inputs
- G Control power
- H Current inputs
- I Status inputs/digital outputs
- J Communications port: Ethernet (PM5300 only) or RS-485

Please see the appropriate *Installation Guide* for accurate and complete information on the installation of this product.



Advanced metering applications

Advanced high performance meters are designed for mains or critical loads on MV/LV networks. They provide analysis of efficiency, losses and capacity, bill verification, power quality compliance monitoring, problem notification and diagnosis and control of loads, etc.

optimizer

Advanced metering

Power quality meters are classified as advanced meters designed to monitor service entrances and critical network locations to maximize power availability and reliability by providing a comprehensive system load profile, power quality and root cause analyses.

- PowerLogic™ PM8000
- PowerLogic™ ION9000



METSEPM8240



M7650

PM8000 Series

The PowerLogic™ PM8000 series meters are compact, cost-effective multifunction power meters that will help you ensure reliability and efficiency of your power-critical facility.

Reveal and understand complex power quality conditions. Measure, understand and act on insightful data gathered from your entire power system. Designed for key metering points throughout your energy infrastructure, the PowerLogic PM8000 series meter has the versatility to perform nearly any job you need a meter to do, wherever you need it!

Applications

Ideal for low to high voltage applications in industrial facilities, data centers, infrastructure and other critical power environments.

PE113687

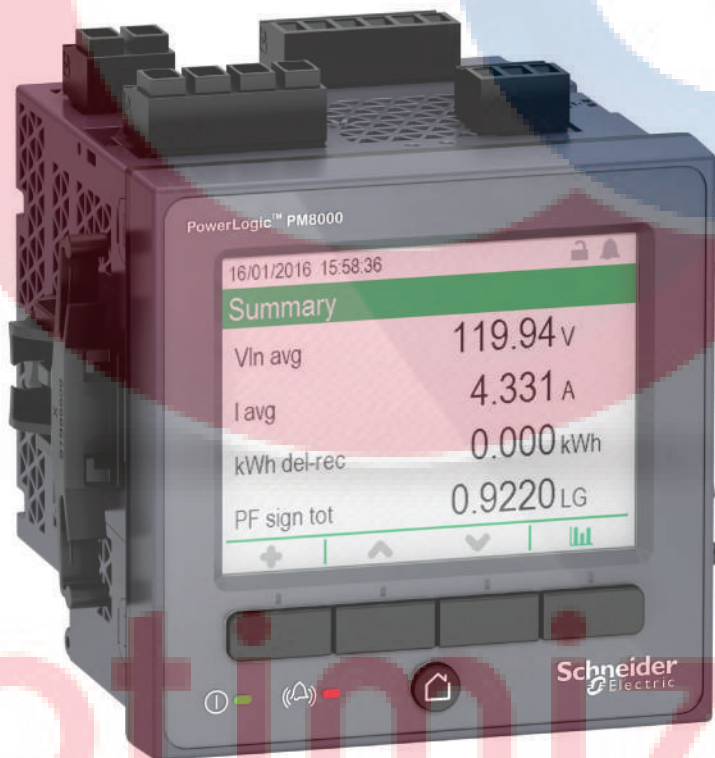

METSEPM8240

PM8000 series

The solution for

Markets that can benefit from a solution that includes PowerLogic PM8000 series meters:

- Industry
- Data centers
- Infrastructure
- Healthcare
- Buildings

Benefits

- Makes understanding power quality simple to help operations personnel avoid downtime and helps ensure increased productivity and equipment life.
- Makes energy and power quality immediately relevant and actionable to support your operational and sustainability goals.

Competitive advantages

- Modular, flexible patented ION technology architecture enables a simple building block approach.
- Disturbance direction detection, modularity and compliance with latest power quality standards.
- Color screen.
- Multiple communication options.
- Excellent accuracy.

Power management solutions

Schneider Electric provides innovative power management solutions to increase your energy efficiency and cost savings, maximize electrical network reliability and availability, and optimise electrical asset performance.

Conformity of standards

- | | |
|------------------|----------------|
| • EN 50160 | • IEC 62053-11 |
| • EN 50470 | • IEC 62053-22 |
| • IEC 61000-4-30 | • IEC 62053-23 |
| • IEC 61010-1 | • IEC 62053-24 |
| • IEC 61326-1 | • IEC 62586-2 |
| • IEC 61557-12 | • IEEE 519 |
| • IEC 62052-11 | • UL 61010-1 |

optimizer

PM8000 series

PB113641



PowerLogic PM8000 series meter.

PB113608

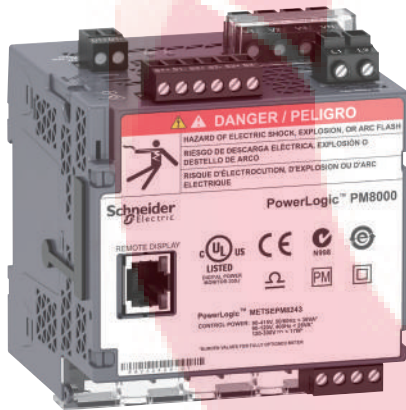

PowerLogic PM8000 series meter - rear view.

PB113692

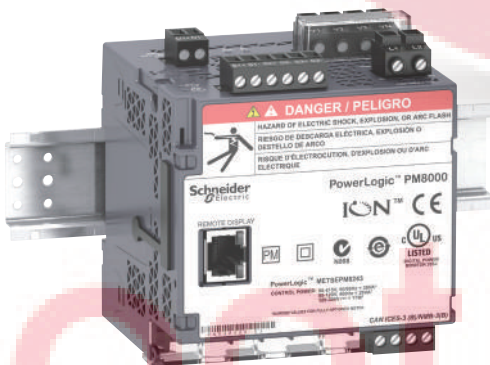

PowerLogic PM8000 DIN rail mounted meter.

Main characteristics

- Precision metering:
 - IEC 61557-12 PMD/SD/K70/0.2 and PMD/SS/K70/0.2 3000m (performance measuring and monitoring functions).
 - Class 0.2S accuracy IEC 62053-22, ANSI C12.20 Class 0.2 (active energy).
 - Industry leading Class 0.5S accuracy for reactive energy (IEC 62053-24).
 - Cycle-by-cycle RMS measurements updated every 1/2 cycle.
 - Full 'multi-utility' WAGES metering support.
 - Net metering.
 - Anti-tamper protection seals.

- PQ compliance reporting and basic PQ analysis:
 - Monitors and logs parameters in support of international PQ standards,
 - IEC 61000-4-30 Class S (test methods as per IEC 62586-2).
 - Generates onboard PQ compliance reports accessible via onboard web pages:
 - Basic event summary and pass/fail reports, for EN 50160 for power frequency, supply voltage indication, supply voltage dips, short and long interruptions, temporary over voltages, voltage unbalance and harmonic voltage.
 - ITIC (CBEMA) and SEMI curves, with alarm categorization to support further analyses.
 - NEMA Motor Derating curve.
 - Pass/fail report for IEEE 519 for voltage and current harmonic limits.
 - Harmonic analysis:
 - THD on voltage and current, per phase, min/max, custom alarming.
 - Individual harmonic magnitudes and angles on voltage and current, up to the 63rd harmonic.
 - High resolution waveform capture: triggered manually or by alarm, captured waveforms available directly from the meter via FTP in a COMTRADE format.
 - Disturbance detection and capture: sag/swell on any current and voltage channel, alarm on disturbance event, waveform capture with pre-event information.
 - Patented disturbance direction detection: provides indication of the captured disturbance occurring upstream or downstream of the meter; timestamped results provided in the event log, with degree of certainty of disturbance direction.

- Used with Schneider Electric's sophisticated software tools, provides detailed PQ reporting across entire network:
 - EN 50160 report.
 - IEC 61000-4-30 report.
 - IEEE 519 harmonic compliance report.
 - PQ compliance summary.
 - Display of waveforms and PQ data from all connected meters.
 - Onboard web-based waveform viewer.
 - Energy reports for consumption analysis and cost management.
 - WAGES dashboards and reports.
 - EcoStruxure Power Events Analysis, including alarm management, sequence of events, and root cause analysis.

- Cybersecurity:
 - Security events logging with Syslog protocol support.
 - HTTPS secure protocol.
 - Ability to enable or disable any communication port and any protocol per port.
 - Anti-tamper protection seals and hardware metrology lock.
 - User accounts with strong passwords.

- Data and event logging:
 - Onboard data and event logging.
 - 512 MB of standard non-volatile memory.

PM8000 series

PB113669



PowerLogic PM8000 series meter with remote display.

PB113671

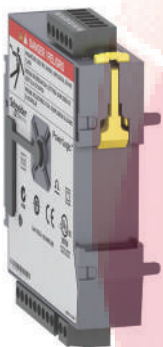

PowerLogic I/O module.

Main characteristics (contd.)

- No data gaps due to network outages or server downtime.
- Min/Max log for standard values.
- 50 user-definable data logs, recording up to 16 parameters on a cycle-by-cycle or other user definable interval.
- Continuous logging or 'snapshot' triggered by setpoint and stopped after defined duration.
- Trend energy, demand and other measured parameters.
- Forecasting via web pages: average, minimum and maximum for the next four hours and next four days.
- Advanced time-of-use capability.
- Security / event log: alarm conditions, metering configuration changes, power outages, firmware download, and user login/logout all timestamped to ± 1 millisecond.

- Alarming and control:
 - 50+ definable alarms to log critical event data, trigger waveform recording, or perform control function.
 - Trigger on any condition, with 1/2-cycle and 1-second response time.
 - Combine alarms using Boolean logic and to create alarm levels.
 - Alarm notification via email.
 - In conjunction with Schneider Electric's EcoStruxure software, alarms, software alarms, and alarm frequency are categorized and trended enabling sequence of events and root cause analyses.

Usability

- Easy installation and setup:
 - Panel and DIN rail mounting options, remote display option.
 - Pluggable connectors.
 - Free setup application simplifies meter configuration.
 - Auto-discovery using DPWS (Device Profile Web Services).
 - DHCP for automatic IP address configuration.
- Front panel:
 - Easy to read color graphic display.
 - Simple, intuitive menu navigation with multi-language (8) support.
- Flexible remote communications:
 - Multiple simultaneously operating communication ports and protocols allow interfacing with other automation systems; (e.g. waveforms, alarms, billing data, etc.) can be uploaded for viewing/analysis while other systems access real-time information.
 - Supports Modbus, ION, DNP3, IEC 61850.
 - Dual port Ethernet: 10/100BASE-TX; supports IPV4 and IPV6; daisy-chaining capability removes need for additional switches.
 - Secure web interface with HTTPS and TLS 1.2 with support for user-provided certificates.
 - Create redundant network loop using Rapid Spanning Tree Protocol (RSTP) and managed Ethernet switches.
 - Customize TCP/IP port numbers and enable/disable individual ports.
 - RS-485 2-wire connection, up to 115,200 baud, Modbus RTU, ION and DNP3 protocols.
 - Ethernet to serial gateway with Modbus Master functionality, connecting to 31 downstream serial Modbus devices. Also supports Modbus Mastering over TCP/IP (Ethernet) network.
 - Full function web server with factory and customizable pages to access real-time and PQ compliance data.
 - Push historical data via email.
 - Advanced security: Up to 50 configurable user accounts.

optimizer

PM8000 series

PB113086

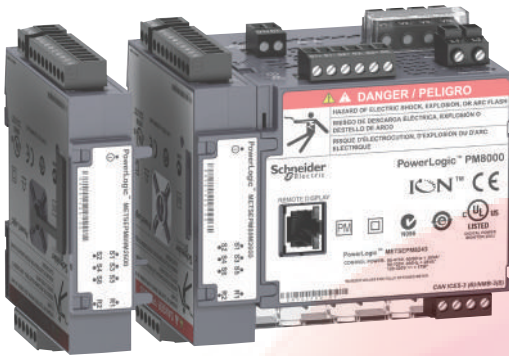

PowerLogic PM8000 series meter with I/O modules.

- Time synchronization via:
 - GPS clock (RS-485) or IRIG-B (digital input) to ± 1 millisecond.
 - Network Time Protocol (NTP/SNTP).
 - Precision Time Protocol (PTP - IEEE 1588 / IEC 61588).
 - Time set function from Schneider Electric software server.

Adaptability

- ION™ frameworks allow customisable, scalable applications, object-oriented programming, compartmentalizes functions, and increases flexibility and adaptability.
- Applications include: access and aggregate data from Modbus devices on serial port or across the network (Modbus TCP/IP), logging and/or processing data by totaling, unit conversion or other calculations, applying complex logic for alarming or control operations, data visualization via web pages.

Standard meter I/O

- 3 digital status/counter inputs.
- 1 KY (form A) energy pulse output for interfacing with other systems.

Modular I/O options

- Optional expansion modules.
- Up to 4 modules per meter.

Option modules include:

- Digital module:
 - 6 digital status/counter inputs.
 - 2 Form C relay outputs, 250 V, 8 A.
- Analog module:
 - 4 analog inputs (4-20 mA; 0-20 mA; 0-30 V).
 - 2 analog outputs (4-20 mA; 0-20 mA; 0-10 V) for interfacing with building management sensors and systems.

PB119094



PowerLogic PM8000 series waveform web page sample

PB119093

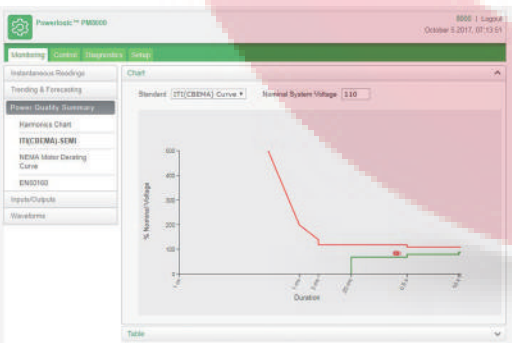

PowerLogic PM8000 series CBEMA web page sample

PB119095

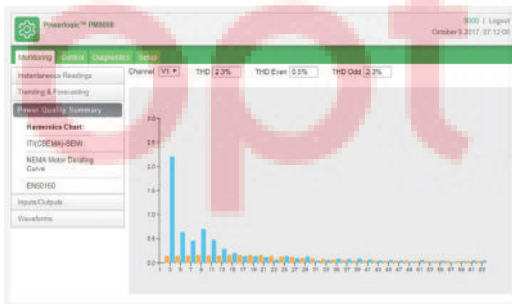

PowerLogic PM8000 series PQ harmonics web page sample

Optimizar

PM8000 series

PB113666

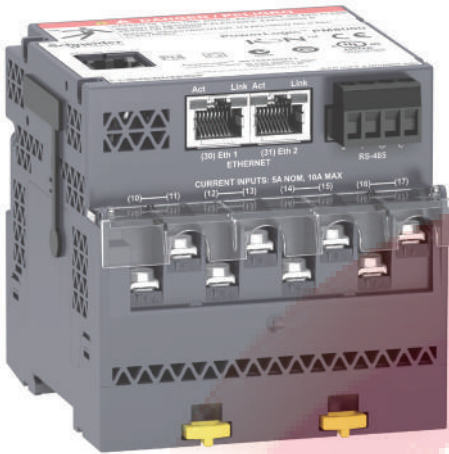

Underside of PM8000 meter (DIN rail version).

Feature selection	
Commercial reference number	Description
METSEPM8240	96 x 96 panel mount meter, AC/DC power.
METSEPM8210	96 x 96 panel mount meter, LV DC power.
METSEPM8243	DIN rail mount meter, AC/DC power.
METSEPM8213	DIN rail mount meter, LV DC power.
METSEPM8244	DIN rail mount meter with remote display, AC/DC power.
METSEPM8214	DIN rail mount meter with remote display, LV DC power.
METSEPM82401	MID approved panel mount meter.
METSEPM82403	RMICAN approved panel mount meter.
METSEPM82404	RMICAN sealed panel mount meter.
Accessories	Description
METSEPM89RD96	Remote display, 3 metre cable, mounting hardware for 30 mm hole (nut & centering pin), mounting hardware for DIN96 cutout (92 x 92 mm) adapter plate
METSEPM89M2600	Digital I/O module (6 digital inputs & 2 relay outputs)
METSEPM89M0024	Analog I/O module (4 analog inputs & 2 analog outputs)
METSEPM8HWK	Replacement hardware kit (connectors, screws, retainer clips, mounting template)

Feature guide		PM8000
General		
Use on LV, MV, and HV systems		■
Current accuracy		0.1 % reading
Voltage accuracy		0.1 % reading
Active energy accuracy		0.2 Class
Number of samples/cycle or sample frequency		256
Instantaneous rms values		
Current, voltage, frequency		■
Active, reactive, apparent power		Total and per phase ■
Power factor		Total and per phase ■
Current measurement range (autoranging)		0.05 - 10 A
Energy values		
Active, reactive, apparent energy		■
Settable accumulation modes		■
Demand values		
Current		Present and max. values ■
Active, reactive, apparent power		Present and max. values ■
Predicted active, reactive, apparent power		■
Synchronization of the measurement window		■
Setting of calculation mode		Block, sliding ■
Power quality measurements		
Harmonic distortion		Current and voltage ■
Individual harmonics		Via front panel and web page 63
		Via EcoStruxure™ software 127
Waveform capture		■
Detection of voltage swells and sags		■
Fast acquisition		1/2 cycle data ■
EN 50160 compliance checking		■
IEEE 519 compliance checking		■
Customizable data outputs (using logic and math functions)		■
Data recording		
Min/max of instantaneous values		■
Data logs		■
Event logs		■
Trending/forecasting		■
SER (Sequence of event recording)		■
Time stamping		■
GPS synchronization (+/- 1 ms)		■
Memory (in Mbytes)		512
Display and I/O		
Front panel display		■
Wiring self-test		■
Pulse output		1
Digital or analog inputs(max)		27 digital 16 analog
Digital or analog outputs (max, including pulse output)		1 digital 8 relay 8 analog
Communication		
RS-485 port		1
Ethernet port		2
Serial port (Modbus, ION, DNP3)		■
Ethernet port (Modbus/TCP, ION TCP, DNP3 TCP, DHCP, DNS, IPv4, IPv6, IEC 61850)		■
Ethernet gateway		■
Alarm notification via email		■
HTTP/HTTPs web server with waveform viewer		■
SNMP with custom MIB and traps for alarms		■
SMTP email		■
PTP and NTP time synchronization		■
FTP file transfer		■

PM8000 series

Technical specifications

Electrical characteristics		
Type of measurement	True rms to 256 samples per cycle	
Measurement accuracy	Current & voltage	Class 0.2 as per IEC 61557-12
	Active Power	Class 0.2 as per IEC 61557-12
	Power factor	Class 0.5 as per IEC 61557-12
	Frequency	Class 0.02 as per IEC 61557-12
	Active energy	Class 0.2S IEC 62053-22 Class 0.2 IEC 61557-12, ANSI C12.20 Class 0.2
	Reactive Energy	Class 0.5S IEC 62053-24*
	MID Directive	EN 50470-1, EN 50470-1, AnnexB & AnnexD (optional model)
Display refresh rate	1/2 cycle or 1 second	
Input-voltage characteristics	Specified accuracy voltage	57 - 400 V L-N / 100 - 690 V L-L
	Impedance	5 M Ω per phase
	Specified accuracy frequency - Frequency	42 to 69 Hz (50/60 Hz nominal)
	Limit range of operation - frequency	20 to 450 Hz
Input-current characteristics	Rated nominal current	1 A (0.2S), 5 A (0.2S) , 10 A (0.2 ANSI)
	Specified accuracy current range	Starting Current: 5 mA Accurate Range: 50 mA - 10 A
	Permissible overload	200 A rms for 0.5s, non-recurring
	Impedance	0.0003 Ω per phase
	Burden	0.01 VA max at 5 A
Power supply AC/DC	AC	90-415 V AC \pm 10 % (50/60 Hz \pm 10 %) 90-120 V AC +/- 10% (400 Hz)
	DC	110-415 V DC \pm 15 % (20-60 V DC \pm 10 % for PM8210)
	Ride-through time	100 ms (6 cycles at 60 Hz) min., any condition 200 ms (12 cycles at 60 Hz) typ., 120 V AC 500 ms (30 cycles at 60 Hz) typ., 415 V AC
	Burden	Typical: 7.7 W / 16 VA at 230 V (50/60 Hz) Fully optioned: max. 18 W / 40 VA at 415 V (50/60 Hz).
Power supply LV DC	DC	20 to 60 V DC \pm 10 %
	Burden	Fully optioned: max. 18 W at 18 to 60 V DC
Input/outputs	Meter Base Only	3 digital inputs (30 V AC/60 V DC) 1 form A (KY) solid state digital output (30 V AC/60 V DC, 75 mA).
	Optional	Digital - 6 digital inputs (30 V AC / 60 V DC) wetted + 2 form C relay outputs (250 V AC, 8 A) Analog - 4 analog inputs (4-20 mA, 0-30 V DC) + 2 analog outputs (4-20 mA, 0-10 V DC).
Mechanical characteristics		
Weight	Integrated Display Model 0.581 kg DIN rail mounted Model 0.528 kg IO modules 0.140 kg Remote display 0.300 kg	
IP degree of protection	IP 54, UL type 12: Panel mount and Remote display, front. IP 30: Panel mount rear, DIN rail mount, I/O modules.	
Excellent quality	ISO 9001 and ISO 14000 certified manufacturing.	
Dimensions	Panel mount model	96 x 96 x 77.5 mm
	DIN model	90.5 x 90.5 x 90.8 mm
	Remote display	96 x 96 x 27 mm
	IO modules	90.5 x 90.5 x 22 mm

PM8000 series

Environmental conditions	
Operating temperature	-25 °C to 70 °C
Remote Display Unit	-25 °C to 60 °C
Storage temperature	-40 °C to 85 °C
Humidity rating	5 % to 95 % non-condensing
Installation category	III
Operating altitude (maximum)	3000 m above sea-level
Electromagnetic compatibility	
EMC standards	IEC 62052-11 and IEC 61326-1
Immunity to electrostatic discharge	IEC 61000-4-2
Immunity to radiated fields	IEC 61000-4-3
Immunity to fast transients	IEC 61000-4-4
Immunity to surges	IEC 61000-4-5
Immunity to conducted disturbances	IEC 61000-4-6
Immunity to power frequency magnetic fields	IEC 61000-4-8
Immunity to conducted disturbances, 2-150kHz	CLC/TR 50579
Immunity to voltage dips & interruptions	IEC 61000-4-11
Immunity to ring waves	IEC 61000-4-12
Conducted and radiated emissions	EN 55022, EN 55011, FCC part 15 Class B, EN55011, EN55022 Class B, ICES-003 Class B
Surge withstand Capability (SWC)	IEEE / ANSI C37.90.1
Safety	
Safety Construction	IEC/EN 61010-1 ed.3, CAT III, 400 V L-N / 690 V L-L UL 61010-1 ed.3 and CSA-C22.2 No. 61010-1 ed.3, CAT III, 347 V L-N / 600 V L-L IEC/EN 62052-11, protective class II.
Communication	
Ethernet to serial line gateway	Communicates directly with up to 31 unit load devices.
Web server	Customisable pages, new page creation capabilities, HTML/XML compatible.
Serial port RS-485	Baud rates of 2400 to 115200, pluggable screw terminal connector.
Ethernet port(s)	2x 10/100BASE-TX, RJ45 connector (UTP).
Protocol	Modbus, ION, DNP3, IEC 61850, HTTPS, FTP, SNMP, SMTP, DPWS, RSTR, NTR, PTP, NTP/SNTP, GPS, IPv4 /IPv6, DHCP, Syslog protocols.
Firmware characteristics	
High-speed data recording	Down to 1/2 cycle interval burst recording, stores detailed characteristics of disturbances or outages. Trigger recording by a user-defined setpoint, or from external equipment.
Harmonic distortion	Up to 63rd harmonic (127th via Schneider Electric software) for all voltage and current inputs.
Sag/swell detection	Analyse severity/potential impact of sags and swells: magnitude and duration data suitable for plotting on voltage tolerance curves per phase triggers for waveform recording, control.
Disturbance direction detection	Determine the location of a disturbance more quickly and accurately by determining the direction of the disturbance relative to the meter. Analysis results are captured in the event log, along with a timestamp and confidence level indicating level of certainty.
Instantaneous	High accuracy of standard speed (1s) and high-speed (1/2 cycle) measurements, including true rms per phase and total for: voltage, current, active power (kW), reactive power (kvar), apparent power (kVA), power factor, frequency, voltage and current unbalance, phase reversal.
Load profiling	Channel assignments (800 channels via 50 data recorders) configurable for any measurable parameter, including historical trend recording of energy, demand, voltage, current, power quality, or any measured parameter. Trigger recorders based on time interval, calendar schedule, alarm/event condition, or manually.
Trend curves	Historical trends and future forecasts to better manage demand, circuit loading, and other parameters. Provides average, min, max and standard deviation every hour for last 24 hours, every day for last month, every week for last 8 weeks and every month for last 12 months.
Waveform captures	Simultaneous capture of all voltage and current channels, sub-cycle disturbance capture, ability to record from 210 cycles at 256 sample per cycle to over 2880 cycles at 16 points per cycle with user selectable sampling speed as well as pre- and post-trigger length.
Alarms	Threshold alarms: adjustable pickup and dropout setpoints and time delays, numerous activation levels possible for a given type of alarm, user-defined or automatic alarm threshold settings, user-defined priority levels (optional automatic alarm setting).
Advanced Time of Use (TOU)	6 seasons; 3 different day types: weekend, weekday, and holiday; up to 8 tariffs per day type.

PM8000 series

Firmware characteristics (cont.)	
Advanced security	Up to 50 users with unique access rights. Perform resets, time sync, or meter configurations based on user privileges.
Memory	512 MB.
Firmware update	Update via the communication ports.
Display characteristics	
Integrated or Remote display	320 x 240 (1/4 VGA) Color LCD, configurable screens , 5 buttons and 2 LED indicators (alarm and meter status).
Languages	English, French, Spanish, Russian, Portugese, German, Italian, Chinese.
Notations	IEC, IEEE.
The HMI menu includes	
Alarms	Active alarms, historic alarms (50+ alarms).
Basic Reading	Voltage, current, frequency, power summary.
Power	Power summary, demand, power factor.
Energy	Energy total, delivered, received.
Events	Timestamped verbose event log.
Power Quality	EN 50160, IEEE 519, harmonics, phasor diagrams.
Inputs/Outputs	Digital inputs, digital outputs, analog inputs, analog outputs.
Nameplate	Model, serial and FW version.
Custom Screens	Build your own metrics.
Setup Menu	Meter setup, communications setup, display setup, date/time/clock setup, alarm setup, language setup, time of use setup, resets, password setup.

PM8000 series parts

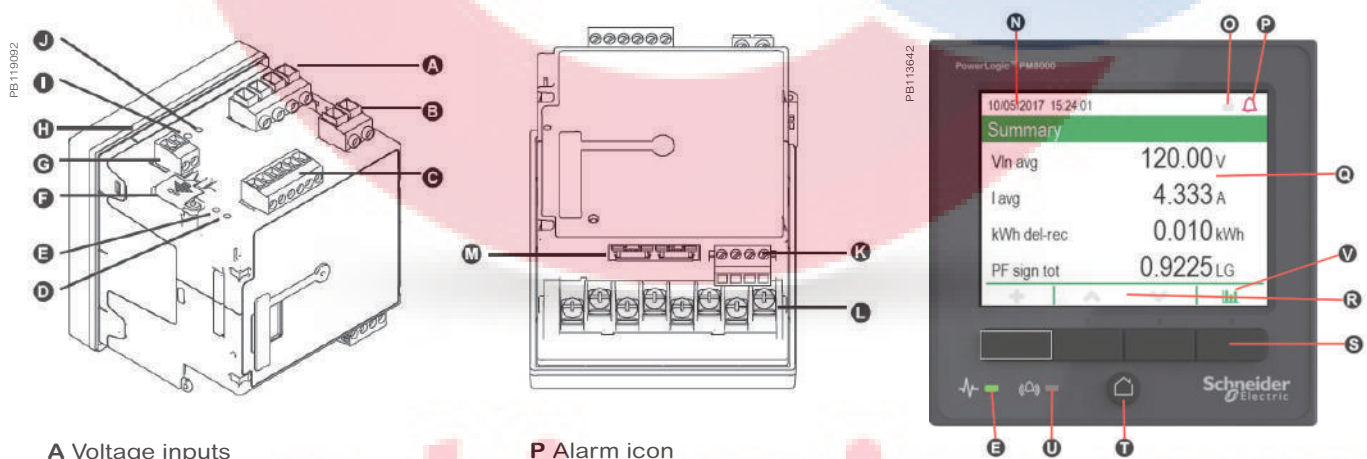

- A Voltage inputs
- B Control power
- C Digital inputs
- D Revenue lock LED (green)
- E Status LED (green/red)
- F Revenue lock switch
- G Digital output
- H Sealing gasket
- I Infrared energy pulsing LED
- J Energy pulsing LED
- K RS-485
- L Current inputs
- M Ethernet (2)
- N Date/time
- O Revenue lock icon

- P Alarm icon
- Q Display
- R Navigation icons
 - ▲ Up
 - ▼ Down
 - ✓ Select
 - ✗ Cancel
 - ⚙ Edit
 - ⊕ More
- S Navigation buttons
- T Home button
- U Alarm LED (red)
- V Bar graph

PM8000 series

PM8000 panel mount meter dimensions

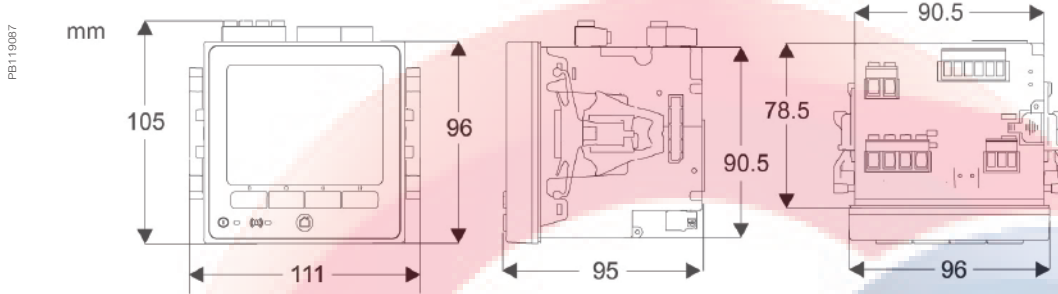

PM8000 DIN rail mount meter dimensions

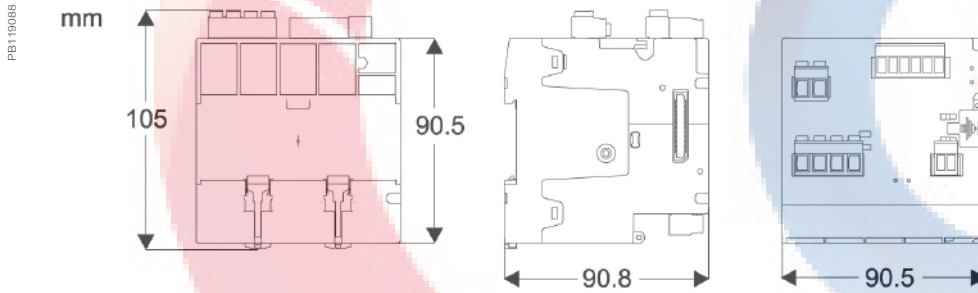

PM8000 remote display dimensions

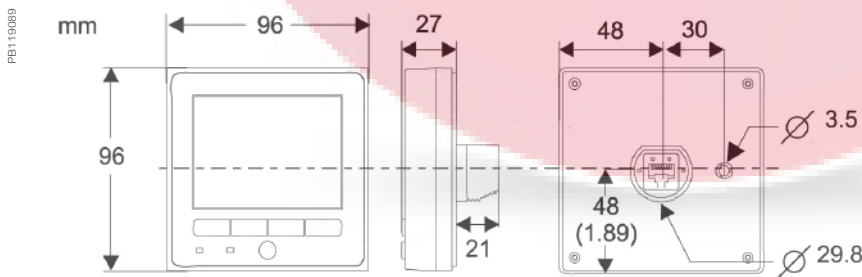

PM8000 with I/O modules dimensions

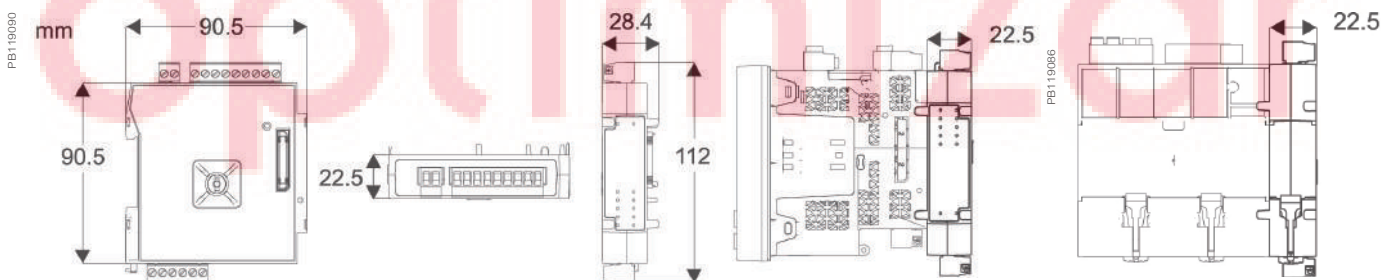

Please see the appropriate **Installation Guide** for accurate and complete information on the installation of this product.

ION9000 Series

The PowerLogic™ ION9000 is your 24/7 power quality expert, providing information, not just data.

With a comprehensive, industry-leading Power Quality Instrument (PQI) performance designation according to IEC 62586-1/-2, the PowerLogic ION9000 is third-party certified ANSI C12.20 Class 0.1 and IEC 62053-22 Class 0.1S accurate, the most accurate power meter available today. Lab-verified power quality and safety ensure reliable, precision performance that is perfect for supply- or demand-side applications. Its patented Disturbance Direction Detection also helps you pinpoint the source of power quality issues faster. Capable of sampling at 10 MHz, the ION9000T captures extremely fast voltage events that are missed by most other power meters, enabling advanced diagnostics and high-resolution event associations for fast, conclusive diagnosis and resolution to transient voltages.

Highly customizable and modular, the ION9000's field programmability can adapt to satisfy any solution, protecting your investment now and in the future. All designed to align with your comprehensive grid cybersecurity policies and backed by Schneider Electric's global services and support.

Applications

Ideal for critical power and large energy users who cannot afford to be shut down, the ION9000T has High-Speed Transient Capture (HSTC) to detect and record transient events that exceed the voltage withstand of sensitive equipment.

PB115917

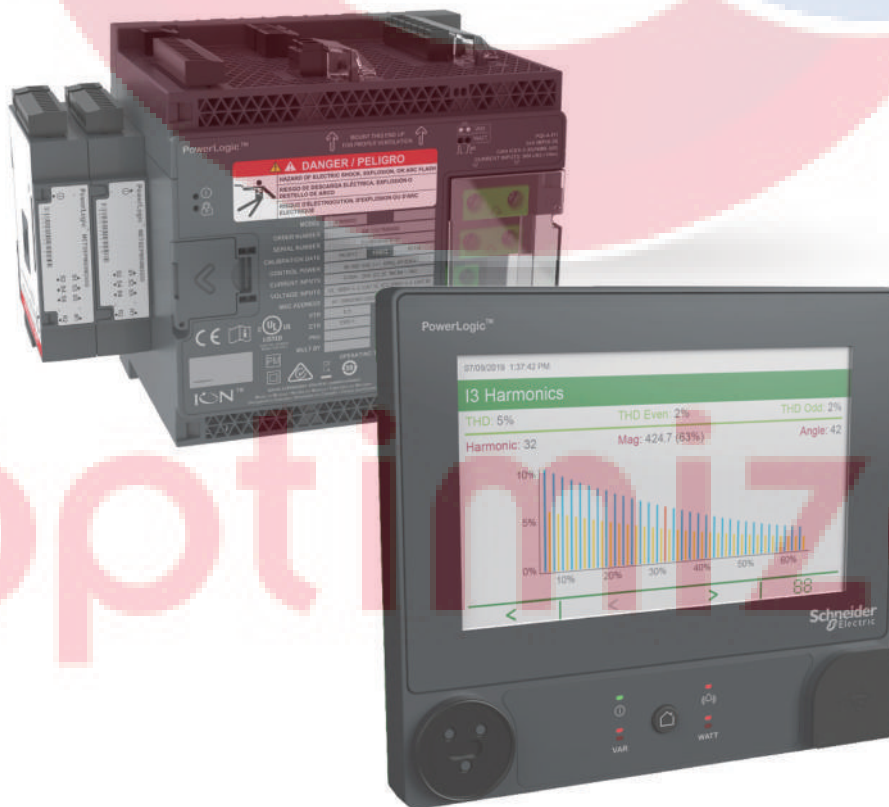

METSEION92040

The market solution for

Markets that benefit from a solution that includes PowerLogic ION9000 series meters:

- Data centers
- Healthcare facilities
- Semiconductor
- Pharmaceutical & chemical
- Energy industries
- Mining, Minerals, & Metals
- Renewable energy interconnects
- Medium voltage distribution & energy automation

Benefits

- Makes understanding power quality simple which helps operations personnel avoid downtime and increase productivity and equipment life
- Makes energy and power quality data immediately actionable and relevant to operational and sustainability goals

Competitive advantages

- Modular, flexible, patented ION™ programmable technology
- Utility grade energy accuracy
- Patented Disturbance Direction Detection
- Third-party, lab-verified compliance with latest PQ standards
- Onboard pass/fail PQ characterization and assessment according to EN50160 and IEEE519
- Cybersecurity event logging, Syslog protocol, HTTPS, SFTP, and full control of each communication port
- High-speed impulsive and oscillatory transient detection

Power management solutions

Schneider Electric provides innovative power management solutions to increase your energy efficiency and cost savings. Maximize electrical network reliability and availability, and optimize electrical asset performance.

Conformity of standards

- ANSI C12.20
- ANSI C37.90.1
- IEC 61000-4-15
- IEC 61000-4-30
- IEC 61010-1
- IEC 61326-1
- IEC 61557-12
- IEC 61850
- IEC 62052-11
- IEC 62052-31
- IEC 62053-22
- IEC 62053-23
- IEC 62053-24
- IEC 62586
- UL 61010-1

optimizer

Main characteristics

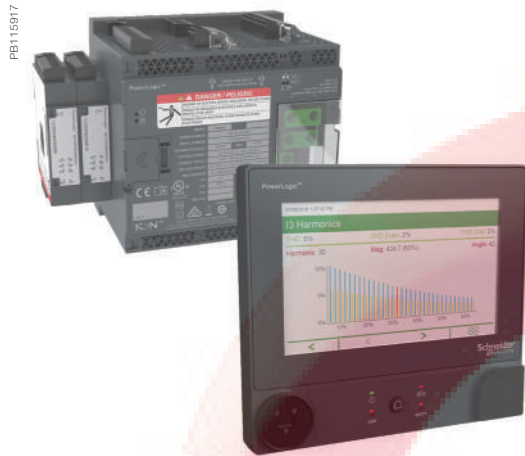

PowerLogic™ ION9000 series meter with RD192 display



PowerLogic™ ION9000 RD192 remote display

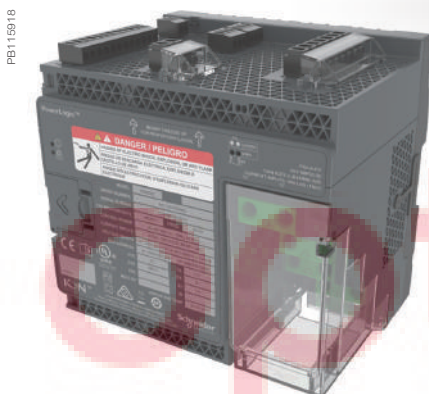

PowerLogic™ ION9000 front view

- PQ compliance reporting and basic PQ analysis:
 - Monitors and logs parameters according to IEC 61000-4-30 Class A international PQ standards (test methods as per IEC 62586-2).
 - High resolution waveform capture: triggered manually or by event. Captured waveforms available directly from the meter via SFTP in a COMTRADE format, and viewable in the meter's web interface.
 - Generates onboard PQ compliance reports accessible via onboard web pages:
 - Pass/fail report for IEEE 519 for voltage and current harmonic limits.
 - ITIC (CBEMA) and SEMI curves, with alarm categorization to support further analyses.
 - NEMA Motor Derating curve.
 - Harmonic analysis:
 - THD and TDD per phase, min/max, custom alarming.
 - Individual harmonic magnitudes and angles on voltage and current, up to the 63rd harmonic.
 - Disturbance detection and capture: sag/swell on any current and voltage channel, alarm on disturbance event, and waveform capture.
 - Patented Disturbance Direction Detection: provides indication of the captured disturbance occurring upstream or downstream of the meter; timestamped results provided in the event log, with degree of certainty of disturbance direction.
- Transient detection and capture: events 20 microseconds or longer in duration on any voltage channel with alarm, event log, and waveform capture.
- PowerLogic ION9000T also provides High-Speed Transient Capture (HSTC) of voltage events 100 nanoseconds or longer in duration and up to 10,000 V in magnitude with high-speed and disturbance waveform captures, as well as per-event statistics on each transient.
- Metering precision:
 - IEC 61557-12 PMD/SD/K70/0.2 and PMD/SS/K70/0.2 3000m (Performance Measuring and Monitoring devices (PMD)).
 - Class 0.1S accuracy IEC 62053-22, ANSI C12.20 Class 0.1 (active energy).
 - Industry leading Class 0.5S accuracy for reactive energy (IEC 62053-24).
 - Cycle-by-cycle RMS measurements updated every ½ cycle.
 - Full 'multi-utility' WAGES metering support.
 - Net metering.
 - Anti-tamper protection seals and hardware metrology lock.
- Cybersecurity:
 - Security events logging with Syslog protocol support.
 - HTTPS and SFTP secure protocols.
 - Ability to enable or disable any communication port and any protocol per port.
 - Anti-tamper protection seals and hardware metrology lock.
 - User accounts with strong passwords.

PB115916

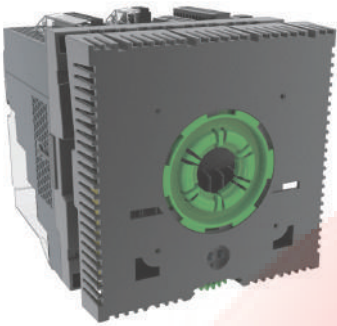

PowerLogic ION9000 with panel mounting adapter

PB115919

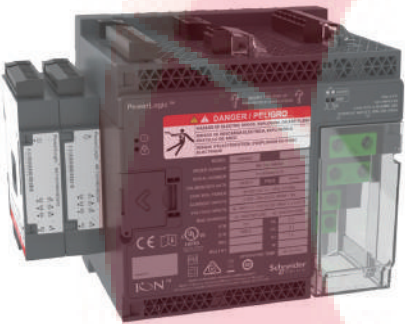

PowerLogic ION9000 front with two option modules

PB115920

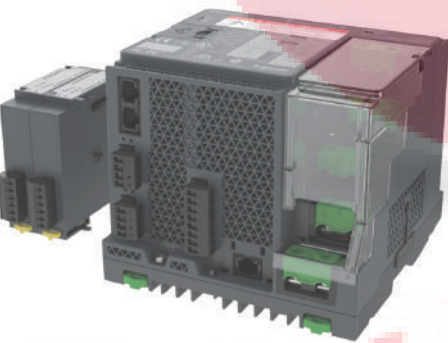

PowerLogic ION9000 bottom with two option modules

- Used with Schneider Electric’s advanced software tools, provides detailed PQ reporting across entire network:

- EN 50160 compliance report.
- IEEE 519 harmonic compliance report.
- IEC 61000-4-30 report.
- Power quality compliance summary.
- Energy reports for consumption analysis and cost management.
- WAGES dashboards and reports.
- Display of waveforms and PQ data from all connected meters.
- Onboard web-based waveform viewer.
- EcoStruxure Power Events Analysis, including alarm management, sequence of events, and root cause analysis.

- Data and event logging:

- Onboard data and event logging.
- 2 GB of standard non-volatile memory.
- No data gaps due to network outages or server downtime.
- Min/max log for standard values.
- 100 user-definable data logs, recording up to 16 parameters at a 1/2 cycle or other user definable interval.
- Continuous logging or snapshot, triggered by setpoint and stopped after defined duration.
- Trend energy, demand and other measured parameters.
- Forecasting via web pages: average, minimum and maximum for the next four hours and next four days.
- Advanced time-of-use capability.
- Security/event log: alarm conditions, metering configuration changes, power outages, firmware download, and user login/logout with timestamp.

- Alarming and control:

- 50+ definable alarms to log critical event data, trigger waveform recording, or perform control function.
- Trigger on any condition, with 1/2-cycle and 1-second response time.
- Combine alarms using Boolean logic enabling customization of alarms.
- Alarm notification via email.
- In conjunction with Schneider Electric’s EcoStruxure software, alarms, software alarms, and alarm frequency are categorized and trended enabling sequence of events and root cause analyses.

Usability

- Auto-discovery using DPWS (Device Profile Web Services).
- DHCP for automatic IP address configuration.
- Full function web server enables simple web commissioning.
- Free setup wizard simplifies meter configuration.
- Front panel:
 - Easy to read color graphic display.
 - Simple and intuitive menu navigation with multiple language interface and support.
- DIN rail mounting options.
- Remote display option.
- Pluggable connectors.



PowerLogic ION9000 Harmonics display

- Flexible remote communications:
 - Multiple simultaneously operating communication ports and protocols allow interfacing with other automation systems, e.g. waveforms, alarms, billing data, etc. Data can be uploaded for viewing/analysis while other systems access real-time information.
 - Supports: Modbus, ION, DNP3, DLMS/COSEM, SNMP, and IEC 61850.
 - Dual port Ethernet: 2x 10/100BASE-TX; supports IPV4 and IPV6; daisy-chaining capability removes need for additional switches.
 - Create redundant network loop using Rapid Spanning Tree Protocol (RSTP) and managed Ethernet switches.
 - Secure web interface with HTTPS and TLS 1.2 with support for user-provided certificates.
 - Customize TCP/IP port numbers and enable/disable individual ports.
 - RS-485 2-wire connection, up to 115,200 baud, Modbus RTU, ION and DNP3 protocols.
 - Ethernet to serial gateway with Modbus Master functionality, connecting to 31 unit loads of downstream serial Modbus devices. Also supports Modbus Mastering over TCP/IP (Ethernet) network.
 - Full function web server with factory and customizable pages to access real-time and PQ compliance data.
 - Push historical data via email.
 - Advanced network security: Up to 50 configurable user accounts.
- Time synchronization via:
 - Precision network time protocol (PTP) based on IEEE 1588 / IEC 61588.
 - GPS clock (RS-485) or IRIG-B (digital input) to ± 1 millisecond.
 - Network Time Protocol (NTP/SNTP).
 - Automatic time synchronization available through Schneider Electric software server.

Adaptability

- ION™ frameworks are customizable, scalable applications with object-oriented programming that compartmentalizes functions, and increases flexibility and adaptability.
- Applications include: access and aggregate data from Modbus devices on serial port or across the network (Modbus TCP/IP), logging and/or processing data by totaling, unit conversion or other calculations, applying complex logic for alarming or control operations, data visualization via web pages.

Standard meter I/O

- 8 digital status/counter inputs with ± 1 millisecond timestamp.
- 4 solid state digital outputs (Form A) for energy pulsing, interfacing with other systems or control.
- 2 Form C relay outputs for control applications.

Modular I/O options

- Optional expansion modules.
- Up to 4 modules per meter.

Option modules include:

- Digital module:
 - 6 digital status/counter inputs.
 - 2 Form C relay outputs, 250 V AC, 8 A.
- Analog module:
 - 4 analog inputs (0-20 mA, 4-20 mA; 0-30 V).
 - 2 analog outputs (0-20 mA, 4-20 mA; 0-10 V) for interfacing with building management sensors and systems.

ION9000 series

Feature guide		
	ION9000	ION9000T
General		
Use on LV, MV, and HV systems	■	■
Current accuracy: 0.1 % reading	■	■
Voltage accuracy: 0.1 % reading	■	■
Active energy accuracy: 0.1 Class	■	■
Number of samples/cycle or sample frequency: 1024	■	■
High-Speed Transient Capture: 10 MHz (200 k for 50 Hz, 167 k for 60 Hz)		■
Instantaneous rms values		
Current, voltage, frequency	■	■
Active, reactive, apparent power: Total and per phase	■	■
Power factor: Total and per phase	■	■
Energy values		
Active, reactive, apparent energy	■	■
Settable accumulation modes	■	■
Demand values		
Current: Present and max. values	■	■
Active, reactive, apparent power: Present and max. values	■	■
Predicted active, reactive, apparent power	■	■
Synchronization of the measurement window	■	■
Setting of calculation mode: Block, sliding	■	■
Power Quality measurements		
Harmonic distortion: Current and voltage	■	■
Individual harmonics: via front panel and web page: 63 via EcoStruxure™ software: 511	■	■
Waveform capture	■	■
Detection of voltage swells and sags	■	■
Fast acquisition: 1/2 cycle data	■	■
EN 50160 compliance checking	■	■
Customizable data outputs (using logic and math functions)	■	■
IEEE 519 compliance checking	■	■
Data recording		
Min/max of instantaneous values	■	■
Data logs	■	■
Event logs	■	■
Trending/forecasting	■	■
SER (Sequence of event recording)	■	■
Time stamping	■	■
GPS synchronization (± 1ms)	■	■
Memory: 2000 MB	■	■
Display and I/O		
Front panel display, 2 options: 96 mm & 192 mm	■	■
Pulse output: 2	■	■
Digital or analog inputs(max): 32 digital, 16 analog	■	■
Digital or analog outputs (max, including pulse output): 4 digital, 10 relay, 8 analog	■	■
Communication		
RS-485 port(s): 2	■	■
Ethernet port(s): 2x 10/100BASE-TX, RJ45 connector, CAT5/5e/6/6a cable	■	■
Serial port protocols (Modbus, ION, DNP3, DLMS/COSEM)	■	■
Ethernet port protocols (Modbus, ION, DNP3, DLMS/COSEM, IEC 61850)	■	■
Ethernet gateway	■	■
Alarm notification via email	■	■
HTTP/HTTPS web server with waveform viewer	■	■
SNMP with custom MIB and traps for alarms	■	■
SMTP email	■	■
PTP and NTP time synchronization	■	■
SFTP file transfer	■	■

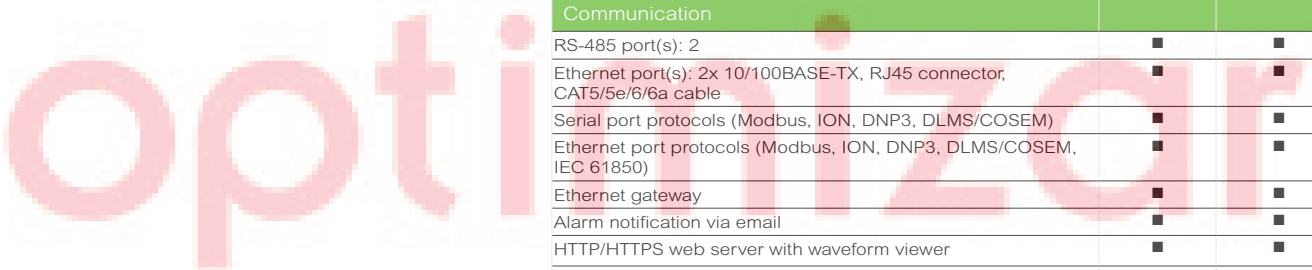

ION9000 series

Technical specifications				
			ION9000	ION9000T
Electrical characteristics				
Type of measurement		True rms to 1,024 samples per cycle	■	■
		High-speed transient detection, 10 MHz, 10 kV		■
Measurement accuracy	Current & voltage	Class 0.1 as per IEC 61557-12	■	■
	Active Power	Class 0.1 as per IEC 61557-12	■	■
	Power factor	Class 0.5 as per IEC 61557-12	■	■
	Frequency	Class 0.02 as per IEC 61557-12	■	■
	Active energy	Class 0.1S IEC 62053-22 Class 0.1 IEC 61557-12 Class 0.1 ANSI C12.20	■	■
	Reactive Energy	Class 0.5S IEC 62053-24	■	■
Display refresh rate		HMI display updated once per second; data refresh rate 1/2 cycle or 1 second	■	■
Input-voltage characteristics	Specified accuracy voltage	57 - 400 V L-N / 100 - 690 V L-L	■	■
	Impedance	5 MΩ per phase	■	■
	Specified accuracy frequency	42 to 69 Hz (50/60 Hz nominal)	■	■
	Limit range of operation - frequency	20 to 450 Hz	■	■
Input-current characteristics	Rated nominal current	1 A (0.1S), 5 A (0.1S); current class 2, 10, 20 A (0.1 ANSI)	■	■
	Specified accuracy current range	Starting Current: 1 mA (no accuracy) Accurate Range: 10 mA - 20 A	■	■
	Permissible overload	500 A rms for 1.0s	■	■
	Impedance	0.0003 Ω per phase	■	■
	Burden	0.01 VA max at 5 A	■	■
Power supply AC/DC	AC	90-480 V AC ±10 % (50/60 Hz ±10 %) 90-120 V AC ±10% (400 Hz)	■	■
	DC	110-480 V DC ±15 %	■	■
	Ride-through time (Values for meters with no optional accessories)	100 ms (5 cycles at 50/60 Hz) typ., 120 V AC 400 ms (20 cycles at 50/60 Hz) typ., 240 V AC 1,200 ms (60 cycles at 50/60 Hz) typ., 480 V AC	■	■
	Burden	Typical: 16.5 W / 38 VA at 480 V (50/60 Hz) Fully optioned: max. 40 W / 80 VA at 480 V (50/60 Hz).	■	■
Input/outputs	Meter base Only	8 digital inputs (30 V AC/60 V DC) 4 Form A (KY) solid state digital output (30 V AC/60 V DC, 75 mA) 2 Form C relays (8 A at 250 V AC, 5 A at 24 V DC)	■	■
	Optional	Digital - 6 digital inputs (30 V AC / 60 V DC) wetted + 2 Form C relay outputs (250 V AC, 8 A)	■	■
		Analog - 4 analog inputs (0-20 mA, 4-20 mA, 0-30 V DC) + 2 analog outputs (0-20 mA, 4-20 mA, 0-10 V DC).	■	■
Mechanical characteristics				
Weight		DIN rail mount meter 1.5 kg IO modules 0.140 kg Touchscreen display 0.300 kg	■	■
IP degree of protection		IP 65, UL type 12: Panel mount and touchscreen display, front. IP 30: Panel mount rear, DIN rail mount, I/O modules.	■	■
Excellent quality		ISO 9001 and ISO 14000 certified manufacturing.	■	■
Dimensions	Panel mount	160 x 160 x 135.3 mm	■	■
	DIN rail mount meter	160 x 160 x 135.3 mm	■	■
	Color remote display (2 options)	197 x 175 x 27.5 mm touchscreen 96 x 96 x 27 mm pushbutton	■	■
	I/O modules	90.5 x 90.5 x 22 mm	■	■
	Touchscreen display(s)	192 mm and 96 mm	■	■

ION9000 series

Environmental conditions		ION9000	ION9000T
Operating temperature	-25 to 70 °C	■	■
Remote Display Unit	-25 to 60 °C	■	■
Storage temperature	-40 to 85 °C	■	■
Humidity rating	5 to 95 % non-condensing	■	■
Installation category	III	■	■
Operating altitude (maximum)	3,000 m above sea-level	■	■
Electromagnetic compatibility			
EMC standards	IEC 62052-11, IEC 61326-1, IEC 61000-6-5	■	■
Immunity to electrostatic discharge	IEC 61000-4-2	■	■
Immunity to radiated fields	IEC 61000-4-3	■	■
Immunity to fast transients	IEC 61000-4-4	■	■
Immunity to surges	IEC 61000-4-5	■	■
Immunity to conducted disturbances	IEC 61000-4-6	■	■
Immunity to power frequency magnetic fields	IEC 61000-4-8	■	■
Immunity to conducted disturbances, 2-150kHz	CLC/TR 50579	■	■
Immunity to voltage dips & interruptions	IEC 61000-4-11	■	■
Immunity to ring waves	IEC 61000-4-12	■	■
Conducted and radiated emissions	EN 55011 and EN 55032 Class B, FCC part 15 Class B, ICES-003 Class B	■	■
Surge withstand Capability (SWC)	IEEE/ANSI C37.90.1	■	■
Safety			
Safety Construction	IEC/EN 61010-1 ed.3, CAT III, 400 V L-N / 690 V L-L, UL 61010-1 ed.3 and CSA-C22.2 No. 61010-1 ed.3, CAT III, 347 V L-N / 600 V L-L, IEC/EN 62052-31, protective class II.	■	■
Communication			
Ethernet to serial line gateway	Communicates directly with up to 31 serial devices.	■	■
Web server	Customizable pages, new page creation capabilities, HTML/XML compatible.	■	■
Serial port RS-485	2x, Baud rates of 2,400 to 115,200, pluggable screw terminal connector.	■	■
Ethernet port(s)	2x 10/100BASE-TX, RJ45 connector, CAT5/5e/6/6a cable.	■	■
Protocol	HTTPS, SFTP, SNMP, SMTP, DPWS, RSTP, PTR, NTP/SNTP, GPS, Syslog, DHCP, IPv4, IPv6.	■	■
Firmware characteristics			
High-speed data recording	Down to 1/2 cycle interval recording, stores detailed characteristics of disturbances or outages. Trigger recording by a user-defined setpoint, or from external equipment.	■	■
Harmonic distortion	Up to 63rd harmonic (511th via Schneider Electric EcoStruxure software) for all voltage and current inputs.	■	■
Sag/swell detection	Analyze severity/potential impact of sags and swells: magnitude and duration data suitable for plotting on voltage tolerance curves per phase triggers for waveform recording.	■	■
Disturbance direction detection	Determine the location of a disturbance more quickly and accurately by determining the direction of the disturbance relative to the meter. Results are captured in the event log, along with a timestamp and confidence level indicating level of certainty.	■	■
Detection and capture of transients	As short as 20 µs at 50 Hz (17 µs at 60 Hz)	■	■
High-speed transient capture	Detection and capture of high-speed impulsive and oscillatory transients as short as 100 ns in duration and up to 10 kV in magnitude. (PowerLogic ION9000T).	■	■
Instantaneous	High accuracy of standard speed (1s) and high-speed (1/2 cycle) measurements, including true rms per phase and total for: voltage, current, active power (kW), reactive power (kvar), apparent power (kVA), power factor, frequency, voltage and current unbalance, phase reversal.	■	■
Load profiling	Channel assignments (1600 channels via 100 recorders) configurable for any measurable parameter, including historical trend recording of energy, demand, voltage, current, power quality, or any measured parameter. Trigger recorders based on time interval, calendar schedule, alarm/event condition, or manually.	■	■
Trend curves	Historical trends and future forecasts to better manage demand, circuit loading, and other parameters. Provides average, min, max, and standard deviation every hour for last 24 hours, every day for last month, every week for last 8 weeks and every month for last 12 months.	■	■

ION9000 series

Firmware characteristics (cont.)		ION9000	ION9000T
Waveform captures	Simultaneous capture of voltage and current channels, sub-cycle disturbance captures of 180-cycles @ 1,024 samples/cycle to 7,200-cycles @ 16 sample/cycle, retriggerable.	■	■
High-speed transient waveform captures	Simultaneous capture of voltage channels, impulsive and oscillatory transient capture of up to 1-cycle @ 200 k samples per cycle (50 Hz) along with coincidence disturbance waveform capture (PowerLogic ION9000T).		■
Alarms	Threshold alarms: adjustable pickup and dropout setpoints and time delays, numerous activation levels possible for a given type of alarm, user-defined or automatic alarm threshold settings, user-defined priority levels (optional automatic alarm setting).	■	■
Advanced Time of Use (TOU)	4 seasons; 5 different day types: weekend, weekday, and holiday; up to 4 tariffs per day type.	■	■
Advanced network security	Up to 50 users with unique access rights. Perform resets, time sync, or meter configurations based on user privileges.	■	■
Memory	2,000 MB.	■	■
Firmware update	Update via the communication ports.	■	■
Display characteristics			
96 mm pushbutton display	320 x 240 (1/4 VGA) color LCD, configurable screens, 5 buttons and 2 LED indicators (alarm and meter status).	■	■
192 mm touchscreen display	800 x 480 pixels, 177.8 mm (7") Color LCD, +/- 85 degree view angle, sunlight readable, dual capacitive touch, usable when wet or through Class 0 lineman gloves, impact resistant to 5 joules, IP65 rating.	■	■
Languages	English, French, Spanish, Russian, Portugese, German, Italian, Chinese.	■	■
Notations	IEC, IEEE.	■	■

ION9000 Commercial reference numbers

Commercial reference number	Description
METSEION92030	ION9000 meter, DIN mount, no display, hardware kit
METSEION92040	ION9000 meter, DIN mount, 192 mm display, B2B adapter, hardware kit
METSEION95030	ION9000T meter, HSTC, DIN mount, no display, hardware kit
METSEION95040	ION9000T meter, HSTC, DIN mount, 192 mm display, B2B adapter, hardware kit
METSEPM89RD96	Remote display, color LCD, 96 x 96 mm
METSERD192	Remote display, color touchscreen, 192 x 192 mm
METSEPM89M2600	I/O module, 2 relay outputs, 6 digital inputs
METSEPM89M0024	I/O module, 2 analog outputs, 4 analog inputs
METSE9HWK	ION9000 meter hardware kit – plugs, terminal guards, spare grounding screw, DIN clips
METSERD192HWK	RD192 remote display hardware kit
METSE9B2BMA	ION9000 B2B (back to back) mounting adapter
METSE9USBK	ION9000 USB cover hardware kit
METSE9CTHWK	ION9000 current input hardware kit – terminal screws and covers
METSE7x4MAK	ION7x50 mounting adapter kit

Contact your Schneider Electric representative for complete ordering information.

optimizer

ION9000 series

ION9000 meter dimensions



ION9000 mounting template

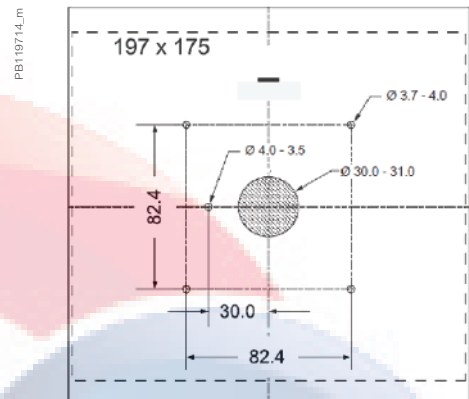

ION9000 back-to-back (B2B) dimensions

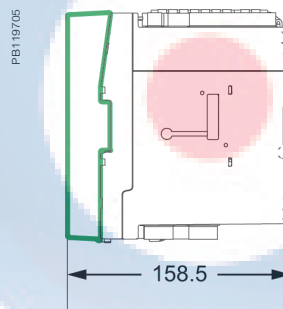

ION9000 192 mm display dimensions

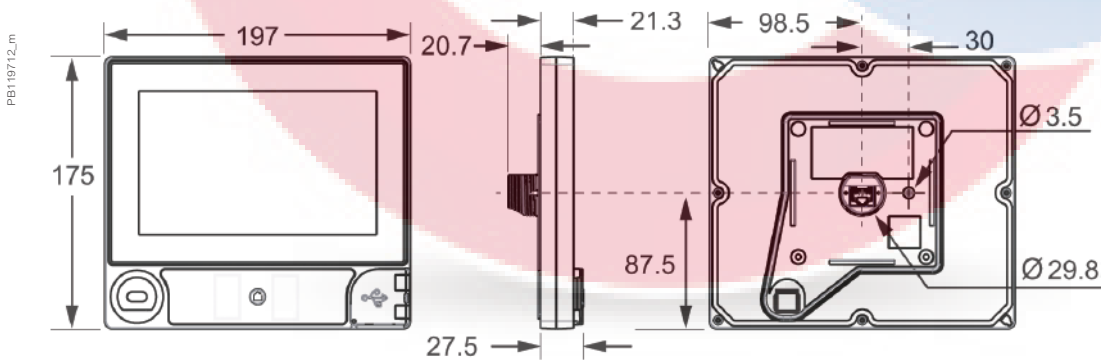

ION9000 96 mm display dimensions

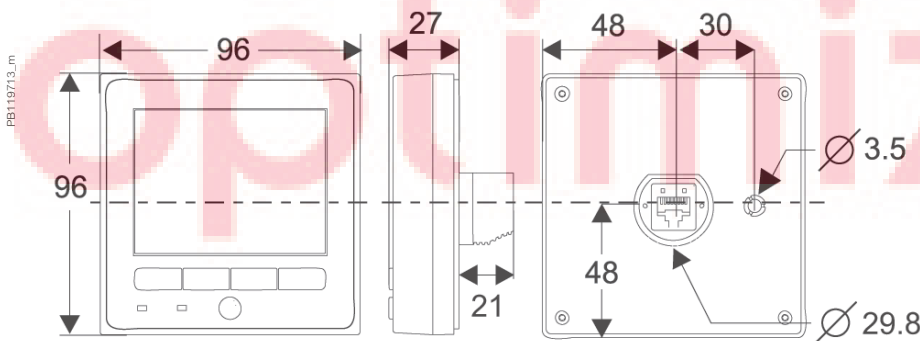

Please refer to ION9000 Series Meter Installation Sheet for accurate and complete information on the installation of this product.

ION9000 series

ION9000 meter DIN rail dimensions

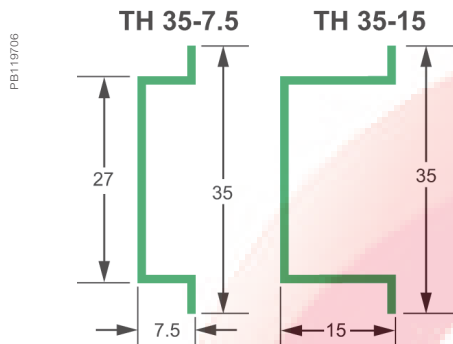

ION7x50 mounting adapter dimensions

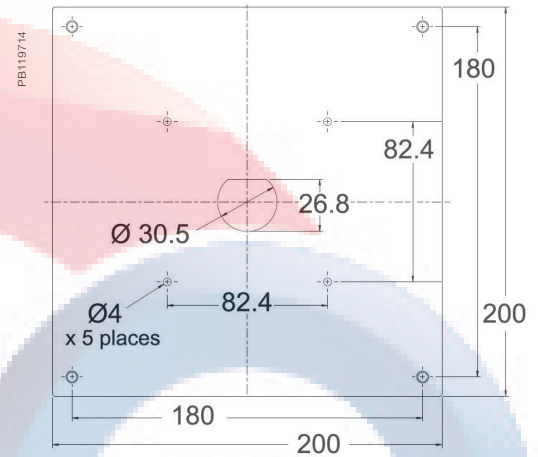

ION9000 meter click installation

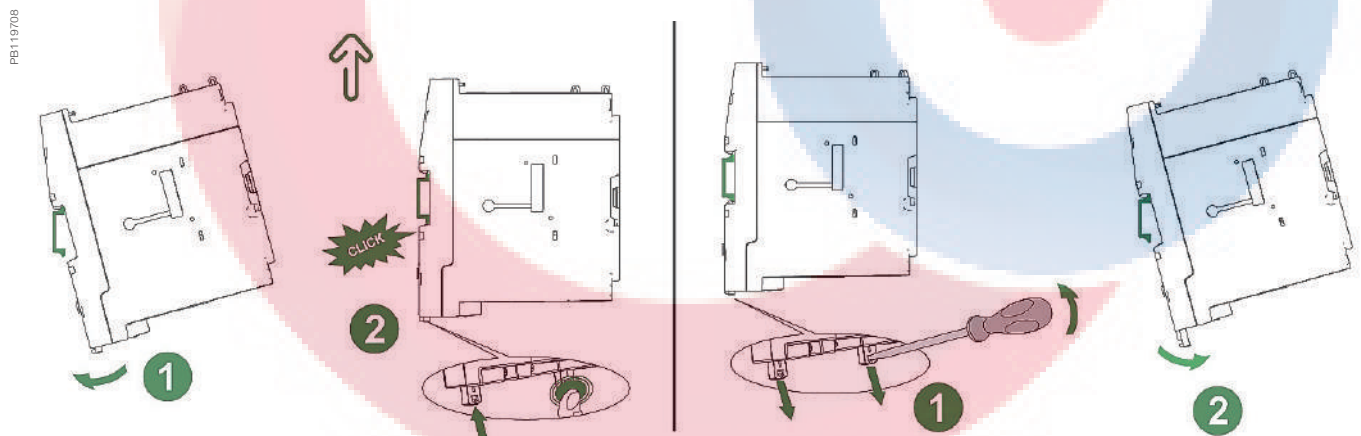

optimizer

Advanced utility metering

Power quality and revenue meters are designed for utility network monitoring, e.g. transmission and distribution network monitoring.

Revenue and power quality meters designed for precision metering at key transmission network inter-ties, distribution substations and service entrances to optimise power reliability and energy efficiency in utility smart grids.

- PowerLogic ION7400
- PowerLogic ION8650
- PowerLogic ION8800



PEB6176
 PB107500
 PB115152



METSEION7400



M8650A



P880CA0A

ION7400 series

Providing high accuracy and a wide range of features for transmission and distribution metering, the versatile PowerLogic ION7400 series advanced utility meter has the flexibility to change along with your needs.

- Compact 3-phase, multifunction energy and power quality compliance
- Flexible and modular installation with object-oriented intelligence
- Accurate, precise, and highly adaptable metering

Applications

- Substation feeder metering
- Revenue metering
- Extensive power quality monitoring and cause analysis
- End feeder line monitoring
- Digital fault recording



METSEION7400

PB115152

The solution for

Markets that can benefit from a solution that includes PowerLogic ION7400 series meters:

- Transmission networks
- Distribution network

Benefits

- Reduce operations costs
- Improve power quality
- Improve continuity of service

Competitive advantages

- Be able to use Power Monitoring Expert software for data analysis or share operation data with SCADA systems through multiple communication channels and protocols
- Transformer/line loss compensation
- Instrument transformer correction
- Utilize disturbance direction detection to help locate fault

Power management solutions

Schneider Electric provides innovative power management solutions to increase your energy efficiency and cost savings, maximise electrical network reliability and availability, and optimise electrical asset performance.

Conformity of standards

- ANSI C12.20
- CLC/TTR50579
- EN 50160
- IEC 61000-4-7
- IEC 61000-4-15
- IEC 61000-4-30
- IEC 61010-1
- IEC 61326
- IEC 61557-12
- IEC 61850
- IEC 62052-11
- IEC 62053-22
- IEC 62053-23
- IEC 62586
- IEEE 519

optimizer



PowerLogic ION7400 meter showing active alarms.

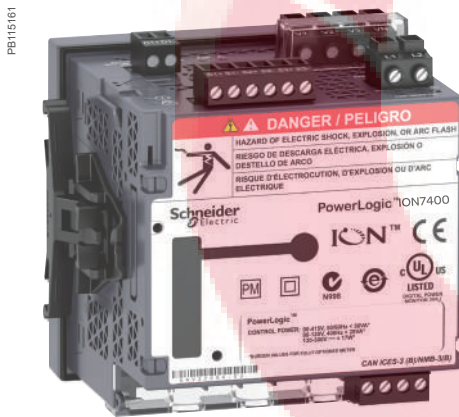

PowerLogic ION7400 meter - rear view.

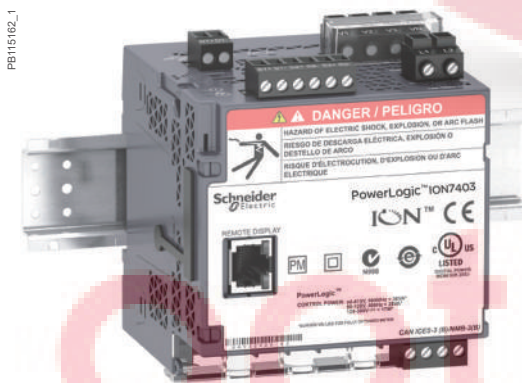

PowerLogic ION7403 DIN rail mounted meter.

Applications and benefits

- Maximize profits by providing the highest output possible with the least amount of risk to availability
- Optimize availability and reliability of electrical systems and equipment
- Monitor power quality (PQ) for compliance and to prevent problems
- Meters fully supported by EcoStruxure™ Power Monitoring Expert and EcoStruxure™ Power SCADA Operation software

Main characteristics

- Precision metering:
 - IEC 61557-12 PMD/Sx/K70/0.2 3000m (performance measuring and monitoring functions)
 - IEC 62053-22 for active energy Class 0.2s accuracy and 0.5s accuracy, ANSI C12.20 Class 0.2 for active energy
 - IEC 62053-23 for reactive energy Class 2 accuracy and Class 3
 - Cycle-by-cycle RMS measurements updated every 1/2 cycle
 - Full 'multi-utility' WAGES metering support
 - Net metering
 - Anti-tamper protection seals
 - Test mode
- PQ Compliance and basic PQ analysis.
 - Monitors and logs parameters in support of international PQ standards,
 - IEC 61000-4-30 Class S
 - IEC 61000-4-15 Flicker
 - IEC 62586
 - EN 50160
 - Generates onboard PQ compliance reports accessible via onboard web pages:
 - Basic event summary and pass/fail reports, such as EN 50160 for power
 - Frequency, supply voltage magnitude, supply voltage dips, short and long interruptions, temporary over voltages, voltage unbalance and harmonic voltage
 - ITIC (CBEMA) and SEMI curves, with alarm categorization to support further analyses
 - Basic meter provides EN 50160 but can be configured to provide IEEE 519
 - Harmonic analysis:
 - THD on voltage and current, per phase, min/max, custom alarming
 - Individual harmonic magnitudes and angles on voltage and current, up to the 63rd harmonic
 - High resolution waveform capture: triggered manually or by alarm, captured waveforms available directly from the meter via FTP in a COMTRADE format or can be viewed via onboard webpages
 - Disturbance detection and capture: sag/swell on any current and voltage channel, alarm on disturbance event, waveform capture with pre-event information
 - Patented disturbance direction detection: provides indication of the captured disturbance occurring upstream or downstream of the meter; timestamped results provided in the event log, with degree of certainty of disturbance direction
- Used with EcoStruxure™ Power Monitoring Expert software, provides detailed PQ reporting across entire network:
 - EN 50160 report
 - IEC 61000-4-30 report
 - PQ compliance summary
 - Display of waveforms and PQ data from all connected meters.



PowerLogic ION7400 with Harmonics display.



PowerLogic remote display.



PowerLogic I/O module.



PowerLogic ION7400 meter with remote display.

- Onboard data and event logging
 - 512 MB of standard non-volatile memory
 - No data gaps due to network outages or server downtime
 - Min/Max log for standard values
 - 50 user-definable data logs, recording up to 16 parameters on a cycle-by-cycle or other user definable interval
 - Continuous logging or 'snapshot' triggered by setpoint and stopped after defined duration
 - Trend energy, demand and other measured parameters
 - Forecasting via web pages: average, minimum and maximum for the next four hours and next four days
 - Time-of-use in conjunction with EcoStruxure™ software
 - Event log: alarm conditions, metering configuration changes, and power outages, timestamped to 1 millisecond
- Alarming and control.
 - 50+ definable alarms to log critical event data, trigger waveform recording, or perform control function
 - Trigger on any condition, with cycle-by-cycle and 1-second response time
 - Combine alarms using Boolean logic and to create alarm levels
 - Alarm notification via email text message
 - In conjunction with EcoStruxure™ Power Monitoring Expert, software alarms and alarm frequency are categorized and trended for easy evaluation of worsening/improving conditions
- Excellent quality: ISO 9001 and ISO 14000 certified manufacturing

Usability

- Easy installation and setup
 - Panel and DIN rail mounting options, remote display option
 - Pluggable connectors
 - Free setup application simplifies meter configuration
- Front panel
 - Easy to read color graphic display
 - Simple, intuitive menu navigation with multi-language (8) support
 - Optical port
 - 2 energy pulsing LEDs
 - Alt/Norm screens.
- Flexible remote communications
 - Multiple simultaneously operating communication ports and protocols allow interfacing with other automation systems; (e.g. waveforms, alarms, billing data, etc.) can be uploaded for viewing/analysis while other systems access real-time information
 - Supports Modbus, ION, DNP3, IEC 61850, MV-90
 - Dual port Ethernet: 10/100BASE-TX; daisy-chaining capability removes need for additional switches
 - Create redundant network loop using Rapid Spanning Tree Protocol (RSTP) and managed Ethernet switches
 - Customize TCP/IP port numbers enable/disable individual ports
 - RS-485 2-wire connection, up to 115200 baud, Modbus RTU and ION protocols, DNP3 is also supported via RS-485.



PowerLogic ION7400 series meter with phasor display.

- Flexible remote communications (cont'd)
 - Ethernet to serial gateway with Modbus Master functionality, connecting to 31 downstream serial Modbus devices. Also supports Modbus Mastering over TCP/IP (Ethernet) network.
 - Full function web server with factory and customizable pages to access real-time and PQ compliance data.
 - Push historical data via email.
 - Advanced security: Up to 16 configurable user accounts.

- Time synchronization via:
 - GPS clock (RS-485) or IRIG-B (digital input) to +/- 1 millisecond.

Also supports Network Time Protocol (NTP/SNTP) and time set function from EcoStruxure software server.

Adaptability

- ION™ frameworks allow customizable, scalable applications, object-oriented programming, compartmentalizes functions, and increases flexibility and adaptability.
- Applications include: access and aggregate data from Modbus devices on serial port or across the network (Modbus TCP/IP), logging and/or processing data by totalizing, unit conversion or other calculations, applying complex logic for alarming or control operations, data visualization via web pages.

Standard meter I/O

- 3 digital status/counter inputs.
- 1 KY (form A) energy pulse output for interfacing with other systems.

Modular I/O options

- Optional expansion modules (up to 4 per meter) add digital/analog I/O.

Option modules include:

- Digital module
 - 6 digital status/counter inputs.
 - 2 Form C relay outputs, 250 V, 8 A
- Analog module.
 - 4 analog inputs (4-20 mA; 0-30 V)
 - 2 analog outputs (4-20 mA; 0-10 V) for interfacing with building management sensors and systems

Standards

- IEC 61000-4-30
- IEC 61000-4-7
- IEC 61000-4-15
- IEC 61326-1
- ANSI C12.20
- IEC 62052-11
- IEC 62053-22
- IEC 62053-23
- CLC/TR50579

Languages supported

- English, French, Spanish, Chinese, Italian, German, Russian, Portuguese

Feature selection	
Commercial reference number	Description
METSEION7400	ION7400 Panel mount meter (integrated display with optical port and 2 energy pulse LEDs)
METSEION7410	ION7400 Panel mount meter (integrated display with optical port and 2 energy pulse LEDs) 20-60 V DC control power
METSEION7403	DIN rail mount - utility meter base
METSEION7413	DIN rail mount - utility meter base 20-60 V DC control power
Accessories	Description
METSEPM89RD96	Remote display, 3 metre cable, mounting hardware for 30 mm hole (nut & centering pin), mounting hardware for DIN96 cutout (92 x 92 mm) adapter plate
METSEPM89M2600	Digital I/O module (6 digital inputs & 2 relay outputs)
METSEPM89M0024	Analog I/O module (4 analog inputs & 2 analog outputs)
METSECAB10	Display Cable, 10 m
METSEPM8000SK	Sealing kit

ION7400 series

PB113696



PowerLogic™ ION7400 bottom view DIN mounting.

Feature guide		ION7400
General		
Use on LV and MV systems		■
Current accuracy (5 A Nominal)		0.1 % reading
Voltage accuracy (90-690 V AC L-L, 50, 60, 400 Hz)		0.1 % reading
Active energy accuracy		0.2 %
Reactive energy accuracy		2 %
Number of samples/cycle or sample frequency		256
Instantaneous rms values		
Current, voltage, frequency		■
Active, reactive, apparent power	Total and per phase	■
Power factor	Total and per phase	■
Current measurement range (autoranging)		0.05 A - 10 A
Energy values		
Active, reactive, apparent energy		■
Settable accumulation modes		■
Demand values		
Current	Present and max. values	■
Active, reactive, apparent power	Present and max. values	■
Predicted active, reactive, apparent power		■
Synchronisation of the measurement window		■
Setting of calculation mode	Block, sliding	■
Power quality measurements		
Harmonic distortion	Current and voltage	■
Individual harmonics	Via front panel and web page	31
	Via EcoStruxure software	63
Waveform capture		■
Detection of voltage swells and sags		■
Flicker		■
Fast acquisition	1/2 cycle data	■
EN 50160 compliance checking		■
Customizable data outputs (using logic and math functions)		■
Data recording		
Min/max of instantaneous values		■
Data logs		■
Event logs		■
Trending/forecasting		■
SER (Sequence of event recording)		■
Time stamping		■
GPS synchronisation (+/- 1 ms)		■
Memory (in Mbytes)		512
Display and I/O		
Front panel display 89 mm TFT		■
Wiring self-test		■
Pulse output		1
Digital		6 In / 2 Out
Analog		4 In / 2 Out
Digital or analog outputs (max. including pulse output)		1 digital 8 relay 8 analog
Communication		
RS-485 port		1
10/100BASE-TX		2
Serial port (Modbus, ION, DNP3, DLMS/COSEM)		■
Ethernet port (Modbus/TCP, ION TCP, DNP3 TCP, IEC 61850, DLMS/COSEM)		■
USB port (mini type B)		■
ANSI C12.19 Optical port		■

All the communications ports may be used simultaneously

ION7400 series

Electrical characteristics		ION7400
Type of measurement		True rms to 256 samples per cycle
Measurement accuracy	Current & voltage	Class 0.2 as per IEC 61557-12
	Active Power	Class 0.2 as per IEC 61557-12
	Power factor	Class 0.5 as per IEC 61557-12
	Frequency	Class 0.2 as per IEC 61557-12
	Active energy	Class 0.2S IEC 62053-22 (In=5A) Class 0.2 IEC 61557-12, ANSI C12.20 Class 0.2
	Reactive Energy	Class 2 IEC 62053-23
Data update rate		1/2 cycle or 1 second
Input-voltage characteristics	Specified accuracy voltage	57 V L-N/100 V L-L to 400 V L-N/690 V L-L
	Impedance	5 MΩ per phase
	Specified accuracy frequency - Frequency	42 to 69 Hz (50/60 Hz nominal)
	Limit range of operation - frequency	20 Hz to 450 Hz
Input-current characteristics	Rated nominal current	1 A (0.2S), 5 A (0.2S) , 10 A (0.2 ANSI)
	Specified accuracy current range	Starting Current: 5 mA Accurate Range: 50 mA - 10 A
	Permissible overload	200 A rms for 0.5s, non-recurring
	Impedance	0.0003 Ω per phase
	Burden	0.024 VA at 10 A
Power supply	AC/DC	90-415 V AC ±10 % 16 VA at 230 V (50/60 Hz ±10%), 110-300 V DC ±10% 18 W (max)
	LV DC	20-60 V DC, ±10 %, 18 W (max)
	Ride-through time	100 ms (6 cycles at 60 Hz) min., any condition 200 ms (12 cycles at 60 Hz) typ., 120 V AC, 110-415 V DC 500 ms (30 cycles at 60 Hz) typ., 415 V AC
	Burden	Meter Only: 18 VA max at 415 V AC, 6W at 300 V DC Fully optioned meter: 36 VA max at 415 V AC, 17 W at 300 V DC.
Input/outputs	Meter Base Only	3 form A digital inputs (30 V AC/60 V DC) 1 form A (KY) solid state digital output (30 V AC/60 V DC, 75 mA).
	Optional	Digital - 6 form A digital inputs (30 V AC / 60 V DC) wetted + 2 form C relay outputs (250 V AC / 30 V DC, 8 A at 250 V AC or 5 A at 24 V DC) Analog - 4 analog inputs (4-20 mA, 0-30 V DC) + 2 analog outputs (4-20 mA, 0-10 V DC).
Mechanical characteristics		
Weight		Integrated Display Model 0.710 kg (without option modules) DIN rail mounted Model 0.530 kg (without remote display or option modules) IO modules 0.140 kg Remote display 0.300 kg
IP degree of protection		IP 54, UL type 12: Panel mount and Remote display, front. IP 30: Panel mount rear, DIN rail mount, I/O modules.
Dimensions	Panel mount model	98 x 112 x 78.5 mm
	DIN model	90.5 x 90.5 x 90.8 mm
	Remote display	96 x 96 x 27 mm
	IO modules	90.5 x 90.5 x 22 mm
Environmental conditions		
Operating temperature		-25 °C to 70 °C
Remote Display Unit		-25 °C to 60 °C
Storage temperature		-40 °C to 85 °C
Humidity rating		5 % to 95 % non-condensing
Installation category		III
Operating altitude (maximum)		3000 m above sea level

ION7400 series

Electromagnetic compatibility	
Product standards	IEC 62052-11 and IEC 61326-1
Immunity to electrostatic discharge	IEC 61000-4-2
Immunity to radiated fields	IEC 61000-4-3
Immunity to fast transients	IEC 61000-4-4
Immunity to surges	IEC 61000-4-5
Immunity to conducted disturbances	IEC 61000-4-6
Immunity to power frequency magnetic fields	IEC 61000-4-8
Immunity to conducted disturbances, 2-150kHz	CLC/TR 50579
Immunity to voltage dips & interruptions	IEC 61000-4-11
Immunity to ring waves	IEC 61000-4-12
Conducted and radiated emissions	EN 55022, EN 55011, FCC part 15, ICES-003
Surge withstand Capability (SWC)	IEEE C37.90.1
Safety	
Safety Construction	IEC/EN 61010-1 ed.3, CAT III, 400 V L-N / 690 V L-L UL 61010-1 ed.3 and CSA-C22.2 No. 61010-1 ed.3, CAT III, 347 V L-N / 600 V L-L IEC/EN 62052-11, protective class II
Communication	
Ethernet to serial line gateway	Communicates directly with up to 32 unit load ION slave devices.
Web server	Customisable pages, new page creation capabilities, HTML/XML compatible.
Serial port RS 485	Baud rates of 2400 to 115200, pluggable screw terminal connector.
Ethernet port(s)	2 x 10/100BASE-TX, RJ45 connector (UTP).
USB port	Virtual serial port supports USB 3.0, 2.0, 1.1 using ION protocol.
Protocol	Modbus, ION, DNP3, IEC 61850, MV-90, DLMS/COSEM, HTTP, FTP, SNMP, SMTP, DPWS, RSTP, NTP, SNTP, GPS protocols.
Firmware characteristics	
High-speed data recording	Down to 1/2 cycle interval burst recording, stores detailed characteristics of disturbances or outages. Trigger recording by a user-defined setpoint, or from external equipment.
Harmonic distortion	Up to 63rd harmonic (via EcoStruxure™ software) for all voltage and current inputs.
Sag/swell detection	Analyse severity/potential impact of sags and swells: magnitude and duration data suitable for plotting on voltage tolerance curves per phase triggers for waveform recording, control.
Disturbance direction detection	Determine the location of a disturbance more quickly and accurately by determining the direction of the disturbance relative to the meter. Analysis results are captured in the event log, along with a timestamp and confidence level indicating level of certainty.
Instantaneous	High accuracy of standard speed (1s) and high-speed (1/2 cycle) measurements, including true rms per phase and total for: voltage, current, active power (kW), reactive power (kvar), apparent power (kVA), power factor, frequency, voltage and current unbalance, phase reversal.
Load profiling	Channel assignments (800 channels via 50 data recorders) configurable for any measurable parameter, including historical trend recording of energy, demand, voltage, current, power quality, or any measured parameter. Trigger recorders based on time interval, calendar schedule, alarm/event condition, or manually.
Trend curves	Historical trends and future forecasts to better manage demand, circuit loading, and other parameters. Provides average, min, max and standard deviation every hour for last 24 hours, every day for last month, every week for last 8 weeks and every month for last 12 months.
Waveform captures	Simultaneous capture of all voltage and current channels sub-cycle disturbance capture, maximum cycles is 100,000 (16 samples/cycle x 96 cycles, 10 MB memory), max 256 samples/cycle.
Alarms	Threshold alarms: adjustable pickup and dropout setpoints and time delays, numerous activation levels possible for a given type of alarm, user-defined or automatic alarm threshold settings, user-defined priority levels (optional automatic alarm setting).

All the communication ports may be used simultaneously.

ION7400 meter parts descriptions

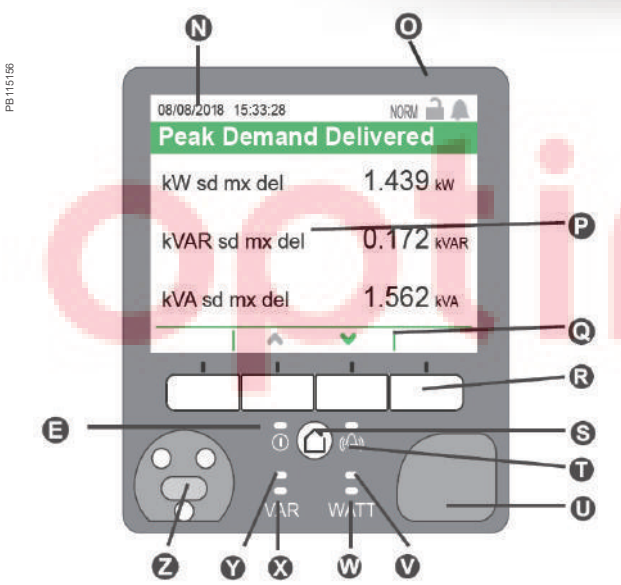
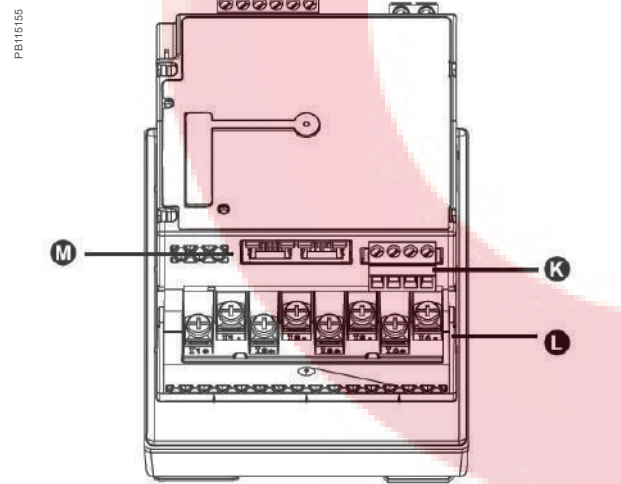
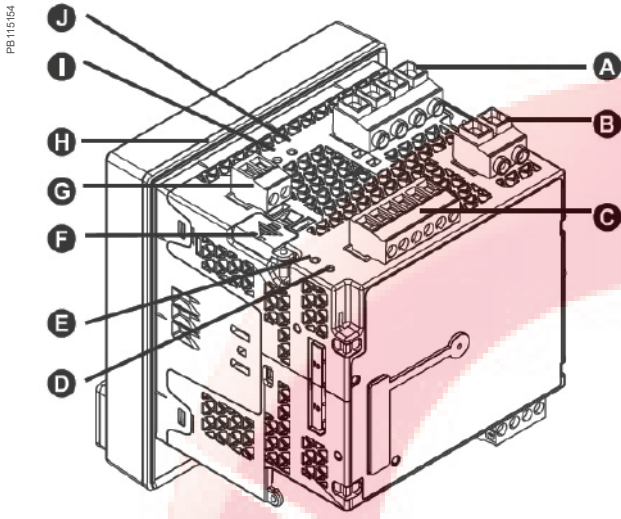

- A Voltage inputs
- B Control power
- C Digital inputs
- D Revenue lock LED
- E Status LED (2 green/red)
- F Revenue lock switch
- G Digital output
- H Sealing gasket
- I Infrared energy pulsing LED
- J Energy pulsing LED
- K RS-485
- L Current inputs
- M Ethernet (2)
- N Date/time
- O Indicator icons
 NORM/ALT Mode Revenue Alarm
- P Display
- Q Navigation icons
 Select Cancel Edit More
- R Navigation buttons
- S Home button
- T Alarm LED (red)
- U USB ports cover
- V Watt energy pulsing LED
- W Watt infrared energy pulsing LED
- X VAR infrared energy pulsing LED
- Y VAR energy pulsing LED
- Z Optical port

PB115154

PB115155

PB115156

ION7400 meter dimensions

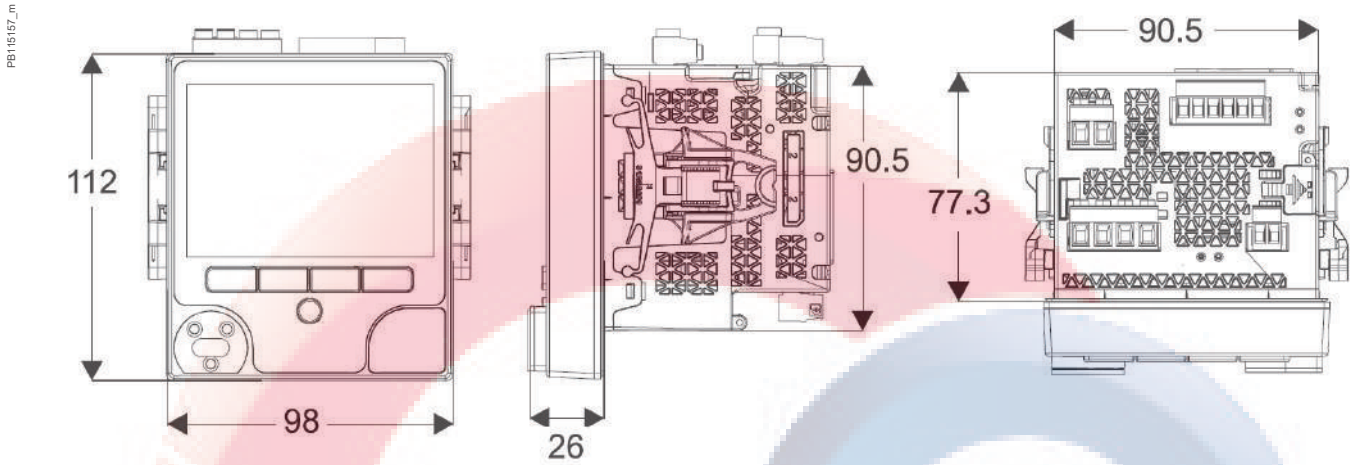

ION7400 panel cutout dimensions

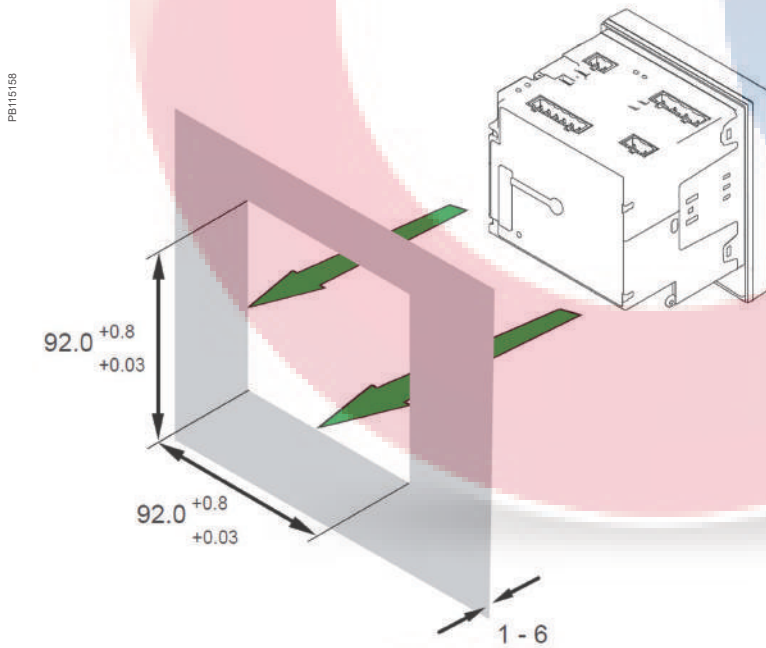

For further details please see appropriate Schneider Electric Installation Guide for this product.

optimizer

ION8650 series

Providing high accuracy and a wide range of features for transmission and distribution metering, the PowerLogic ION8650 advanced revenue and power quality meter has the flexibility to change along with your needs. The meter provides the tools necessary to:

- Manage energy procurement and supply contracts
- Perform network capacity planning and stability analysis
- Monitor power quality compliance, supply agreements, and regulatory requirements

Applications

- Transmission and distribution metering
- Revenue metering
- Extensive power quality monitoring and analysis
- Power quality compliance monitoring
- Digital fault recording
- Instrument transformer correction

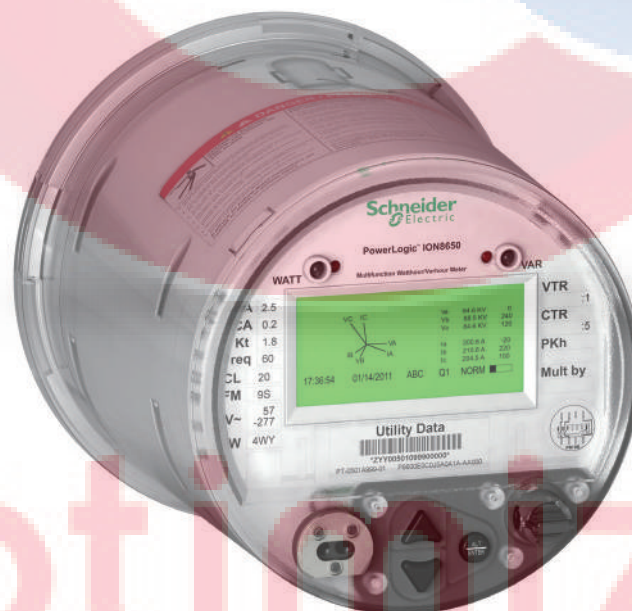

M8650A

PB107500

The solution for

Markets that can benefit from a solution that includes PowerLogic ION8650 series meters:

- Transmission networks
- Distribution network

Benefits

- Reduce operations costs
- Improve power quality
- Improve continuity of service

Competitive advantages

- Be integrated into existing wholesale settlement system
- Be able to use Power Monitoring Expert software for data analysis or share operation data with SCADA systems through multiple communication channels and protocols
- Transformer/line loss compensation
- Instrument transformer correction

Power management solutions

Schneider Electric provides innovative power management solutions to increase your energy efficiency and cost savings, maximise electrical network reliability and availability, and optimise electrical asset performance.

Conformity of standards

- IEC 62053-22/23
- IEC 61000-4-30
- EN 50160
- IEC 61000-4-7
- IEC 61000-4-15
- IEEE 1159
- IEEE 519
- IEC 61000-4-2
- IEC 61000-4-3
- IEC 61000-4-4
- IEC 61000-4-5
- IEC 61000-4-6
- IEC 61000-4-12
- CISPR 22
- IEC 62052-11
- IEC 60950
- ANSI C12.20

optimizer

PB107500



PowerLogic ION8650 socket meter

Main characteristics

Used to monitor electric energy provider networks, service entrances and substations, PowerLogic ION8650 meters are ideal for independent power producers and cogeneration applications that need to accurately measure energy bi-directionally in both generation and stand-by modes. These meters give utilities the tools to manage complex energy supply contracts that include commitments to power quality. Integrate them with our EcoStruxure™ Power Monitoring operations software or other energy management and SCADA systems through multiple communication channels and protocols, including Itron MV-90, Modbus, DNP, DLMS, IEC 61850 Ed. 3.

Applications

- Revenue metering.
- Cogeneration and IPP monitoring.
- Compliance monitoring.
- Power quality analysis.
- Demand and power factor control.
- Load curtailment.
- Equipment monitoring and control.
- Energy pulsing and totalisation.
- Instrument transformer correction.
- Outage Notification

Main characteristics

- ANSI Class 0.1 and IEC 62053-22/23 Class 0.2 S metering
 - For interconnection points on medium, high, and ultra-high voltage networks; twice as accurate as current IEC and meets ANSI Class standards over all conditions and including single wide range current measurement.
- Power quality compliance monitoring
 - Monitor compliance with international quality-of-supply standards (IEC 61000-4-30 Ed. 3 Class A/S, EN 50160 Ed. 4, IEC 61000-4-7, IEC 61000-4-15, IEEE 1159, IEEE 519). Also detects disturbance direction.
- Digital fault recording
 - Simultaneous capture of voltage and current channels for sub-cycle disturbance.
- Complete communications
 - Multi-port, multi-protocol ports including serial, infrared, modem and ethernet. Simultaneously supports multiple industry standard protocols including: Itron MV-90, Modbus, Modbus Master, DLMS, DNP 3.0 and IEC 61850 Ed. 2. Cell modem option using CDMA or LTE.
- Multiple tariffs and time-of-use
 - Apply tariffs, seasonal rate schedules to measure energy and demand values for time periods with specific billing requirements.
- Multiple setpoints for alarm and functions
 - Use up to 65 setpoints for single/multi-condition alarms and I/O functions with response times down to 1/2 cycle.
- Multiple setpoints for alarm and functions
 - Use up to 65 setpoints.
- Instrument transformer correction
 - Save money and improve accuracy by correcting for less accurate transformers.
- Alarm notification via email
 - High-priority alarms, data logs sent directly to the user's PC. Instant notification of power quality events by email.
- Cyber security enhancements
 - Assign communication admin rights to selected user; prevention measures ensure no loss of security logs; support syslog for external security.

Feature selection	
Commercial reference number	ION8650 meters
S8650A	ION8650A
S8650B	ION8650B
S8650C	ION8650C



PowerLogic ION8650 switchboard meter.

- 1 Terminals
- 2 Optical port
- 3 Main display status bar
- 4 Watt LED
- 5 Navigation, ALT/Enter buttons
- 6 VAR LED
- 7 Nameplate label
- 8 Demand reset switch

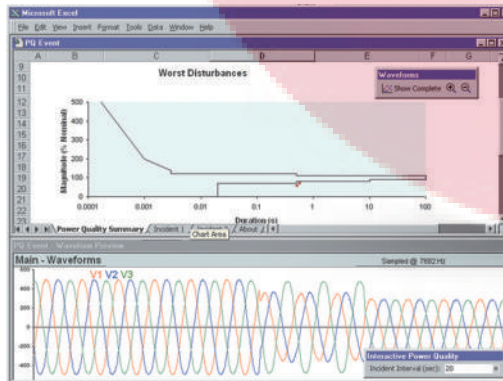

Disturbance waveform capture and power quality report

Selection guide	ION8650 A	ION8650 B	ION8650 C
General			
Use on LV, MV and HV systems	■	■	■
Current accuracy	0.1 %	0.1 %	0.1 %
Voltage accuracy	0.1 %	0.1 %	0.1 %
Power accuracy	0.1 %	0.1 %	0.1 %
Samples/cycle	1024	1024	1024
Instantaneous values			
Current, voltage, frequency	■	■	■
Active, reactive, apparent power	Total & per phase		
Power factor	Total & per phase		
Current measurement range	0 A - 20 A	0 A - 20 A	0 A - 20 A
Energy values			
Active, reactive, apparent energy	■	■	■
Settable accumulation modes	■	■	■
Demand values			
Current	Present & max values		
Active, reactive, apparent power	Present & max values		
Predicted active, reactive, apparent power	■	■	■
Synchronisation of the measurement window	■	■	■
Demand modes: Block (sliding), thermal (exponential)	■	■	■
Power quality measurements			
Harmonic distortion	Current & voltage		
Individual harmonics	Via front panel		
Waveform / transient capture	■ / ■	- / ■	- / -
Harmonics: magnitude, phase, and interharmonics	50	40	-
Detection of voltage sags and swells	■	■	■
IEC 61000-4-30 class A / S	A	S	-
IEC 61000-4-15 (Flicker)	■	■	-
High speed data recording (down to 10 ms)	■	■	-
EN 50160 compliance reporting	■	■	-
Programmable (logic and math functions)	■	■	■
Data recording			
Onboard Memory (in Mbytes)	128	64	32
Revenue logs	■	■	■
Event logs	■	■	■
Historical logs	■	■	■
Harmonics logs	■	■	■
Sag/swell logs	■	■	■
Transient logs	■	-	-
Time stamping to 1 ms	■	■	■
GPS synchronisation (IRIG-B standard)	■	■	■
Display and I/O			
Front panel display	■	■	■
Wiring self-test (requires PowerLogic ION Setup)	■	■	■
Pulse output (front panel LED)	2	2	2
Digital or analog inputs* (max)	11	11	11
Digital or analog outputs* (max, including pulse output)	16	16	16
Communication			
Infrared port	1	1	1
RS-485 / RS-232 port	1	1	1***
RS-485 port	1	1	1***
Ethernet port (Modbus/TCP/IP protocol) with gateway	1	1	1***
Internal modem with gateway (ModemGate)	1	1	1***
HTML web page server	■	■	■
IRIG-B port (unmodulated IRIG B00x time format)	1	1	1
Modbus TCP Master / Slave (Ethernet port)	■ / ■	■ / ■	- / ■
Modbus RTU Master / Slave (Serial ports)	■ / ■	■ / ■	- / ■
DNP 3.0 through serial, modem, and I/R ports	■	■	■
Cell modem option (CDMA/LTE)	■	■	■
DLMS COSEM through serial, Ethernet and optical ports for all variants	■	■	■

* With optional I/O Expander.

** For 9S, and 36S only. For 35S system up to 480 V L-L.

*** C model limited to IR + 2 other ports at one time. Ports can be enabled/disabled by user.

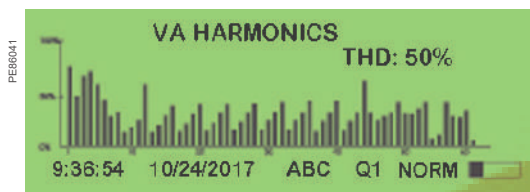

PowerLogic ION8650 front panel harmonic display.

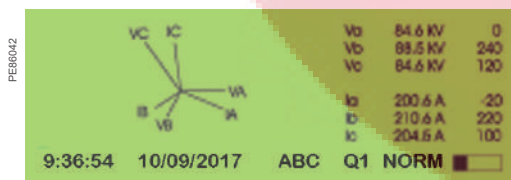

ION8650 front panel phasor display and table.

Electrical characteristics		
Type of measurement		True rms 1024 samples per cycle
Measurement accuracy	Current and voltage	0.1 % Reading
	Power	0.1 %
	Frequency	±0.001 Hz
	Power factor	0.1 %
	Energy	0.1 %, twice as accurate as ANSI Class 0.2 and IEC 62053-22/23 (0,2S)
Data update rate		0.5 cycle or 1 second (depending on value)
Input-voltage characteristics*	Nominal voltage	57 V to 277 V L-N rms 100 V to 480 V L-L rms (35S)
	Maximum voltage	347 V L-N rms, 600 V L-L rms (9S)
	Impedance	5 MΩ /phase (phase-Vref/Ground)
	Inputs	V1, V2, V3, VREF
Input-current characteristics	Rated nominal/current class	1A, 2 A, 5 A and/or 10 A (Class 1/2/10/20)
	Accuracy range	0.01 - 20 A (standard range)
	Measurement range	0.001 - 24 A
	Permissible overload	500 A rms for 1 second, non-recurring
Power supply	Burden per phase	Socket: Typical: 3 W, 8 VA/phase, 3-phase operation; Maximum: 4 W, 11 VA/phase, 3-phase operation Switchboard: 0.05 V A at 1 A (0.05 Ω max)
	Standard power supply, blade powered	120-277 V L-N RMS (-15 %/+20 %) 47-63 Hz or 120-480 V L-L RMS (-15 %/+20 %) 47-63 Hz (35S)
	Auxiliary powered low voltage	AC: 65-120 (+/- 15 %) VLN RMS, 47-63 Hz DC: 80-160 (+/- 20 %) VDC
	Auxiliary powered high voltage	AC: 160-277 (+/- 20 %) V L-N RMS, 47-63 Hz DC: 200-300 (+/- 20 %) V DC
Input/outputs**	Ride-through time, (Standard power supply)	Socket: min guaranteed: 6 cycles at nominal frequency (minimum 50 Hz), at 120 V L-N rms (208 V L-L rms) 3-phase operation Switchboard: min guaranteed: 6 cycles at nominal frequency (minimum 50 Hz), at 120 V L-N rms (208 V L-L rms) 3-phase operation
	Digital outputs	4 (Form C) Solid state relays (130 V AC/ 200 V DC) 50 mA AC/DC, 1 (Form A) output
	Digital inputs	upto 3 Self-excited, dry contact sensing inputs
Mechanical characteristics		
Weight		7.0 kg
IP degree of protection	Socket	Front IP65, back IP51
	Switchboard	Front IP50, back IP30
Dimensions	Socket	178 x 237 mm
	Switchboard	285 x 228 x 163 mm
Environmental conditions		
Operating temperature		-40 °C to 85 °C
Display operating range		-40 °C to 70 °C
Storage temperature		-40 °C to 85 °C
Humidity rating		5 % to 95 % RH non-condensing
Pollution degree		2
Installation category		Cat III
Dielectric withstand		2.5 kV
Electromagnetic compatibility		
Electrostatic discharge		IEC 61000-4-2
Immunity to radiated fields		IEC 61000-4-3
Immunity to fast transients		IEC 61000-4-4
Immunity to surge		IEC 61000-4-5
Immunity conducted		IEC 61000-4-6
Damped oscillatory waves immunity		IEC 61000-4-12
Conducted and radiated emissions		CISPR 22 (class B)
Safety		
Europe		As per IEC 62052-11
North America		As per ANSI C12.1

* Specifications are limited by the operating range of the power supply if a non-aux power supply is used.

** More input and output selections available via optional I/O expander.

PB117744

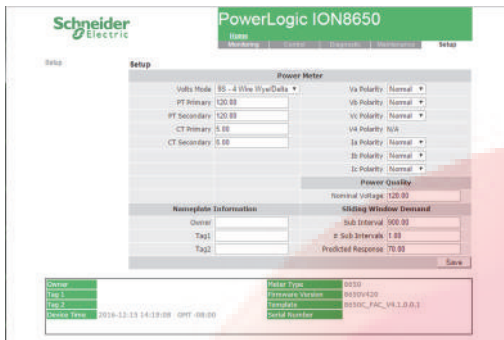

Example embedded webserver page (WebMeter) showing realtime values.

Communication	
RS-232 / RS-485 port (COM1)	User-selectable RS-232 or RS-485. 300 - 115,200 baud (RS-485 limited to 57,600 bps); protocols: ION, Modbus/RTU/Mastering, DLMS, DNP 3.0, GPSTRUETIME/DATUM.
Internal modem port (COM2)	300-57,600 bps
Cell modem option (CDMA/LTE)	CDMA2000 1xRTT / EV-DO Rev A (backwards compatible to EVDO Rev. 0 and CDMA 1x networks) 800/1900 MHz. MTSMC-LVW3 / LTE FDD Cat 1, 3GPP release 9 compliant, 4G: 1900 (B2) / 700 (B13) / AWS 1700 (B4)
ANSI 12.18 Type II optical port (COM3)	Up to 57,600 bps
RS-485 port (COM4)	Up to 57,600 baud, Modbus, direct connection to a PC or modem
Ethernet port	10/100BASE-T, RJ45 connector, protocols: DNP, ION, Modbus/TCP/Mastering, IEC 61850 Ed. 2 or 100BASE-FX multimode, male ST connectors, DLMS
EtherGate	Up to 31 slave devices via serial ports
ModemGate	Up to 31 slave devices
Firmware characteristics	
High-speed data recording	Up to 1/2-cycle interval burst recording, stores detailed characteristics of disturbances or outages. Trigger recording by a user-defined setpoint, or from external equipment.
Harmonic distortion	Up to 63rd harmonic for all voltage and current inputs
Dip/swell detection	Analyse severity/potential impact of sags and swells: <ul style="list-style-type: none"> - magnitude and duration data suitable for plotting on voltage tolerance curves - per phase triggers for waveform recording or control operations
Instantaneous	High accuracy measurements with 1s or 1/2 cycle update rate for: <ul style="list-style-type: none"> - voltage and current - active power (kW) and reactive power (kVAR) - apparent power (kVA) - power factor and frequency - voltage and current unbalance - phase reversal
Load profiling	Channel assignments are user configurable: <ul style="list-style-type: none"> - 800 channels via 50 data recorders (feature set A), - 720 channels via 45 data recorders (feature set B), - 80 channels via 5 data recorders (feature set C). Configure for historical trend recording of energy, demand, voltage, current, power quality, other measured parameters. Recorders can trigger on time interval basis, calendar schedule, alarm/event condition, manually.
Waveform captures	Simultaneous capture of all voltage and current channels <ul style="list-style-type: none"> - sub-cycle disturbance capture (16 to 1024 samples/cycle)
Alarms	Threshold alarms: <ul style="list-style-type: none"> - adjustable pickup and dropout setpoints and time delays, numerous activation levels possible for a given type of alarm - user-defined priority levels - boolean combination of alarms
Advanced security	Up to 50 users with unique access rights. Perform resets, time syncs, or meter configurations based on user privileges.
Transformer correction	Correct for phase / magnitude inaccuracies in current transformers (CTs), potential transformers (PTs)
Memory	128 MB (A), 64 MB (B), 32 MB (C)
Firmware update	Update via the communication ports
Display characteristics	
Type	FSTN transreflective LCD
Backlight	LED
Languages	English

1 2 3 4 5 6 7 8 9 10 11
M 8 6 5 0 A 1 C 0 E 5 C 1 A 0 A

- 1 Model.
- 2 Feature set.
- 3 Form factor.
- 4 Current Inputs.
- 5 Voltage inputs.
- 6 Power supply.
- 7 System frequency.
- 8 Communications.
- 9 Input/output options.
- 10 Security.
- 11 Special order options.



PowerLogic ION8650 meter with switchboard case

Commercial reference numbers

Item	Code	Description
1	Model	M8650 Schneider Electric energy and power quality meter.
2	Feature Set	A 128 MB Memory Class A power quality analysis, waveforms and transient capture with 1024 samples/cycle.
		B 64 MB memory, energy meter Class S EN 50160 Ed. 4 power quality monitoring.
		C 32 MB memory, basic tariff/energy metering (5 data recorders, 80 channels).
3	Form Factor (1)	0 Form 9S/29S/36S Base, 57-277 V L-N (autoranging) 3-Element, 4-Wire / 2 1/2-Element, 4-Wire
		1 Form 35S Base - 120-480 V L-L (autoranging) 2-Element, 3-Wire
		4 Form 9/29/35/36S FT21 Switchboard (meter + case) with break out panel
		7 Form 9/29/35/36S FT21 Switchboard (meter + case) with break out cable
4	Current Inputs	C 1, 2 or 5 A nominal, 20 A full scale (24 A fault capture, start at 0.001 A)
5	Voltage Inputs	0 Standard (see Form Factor above)
6	Power Supply*	E Form 9/29/35/36S, (socket) and Form 9, 36 (FT21 switchboard): 120-277 V AC. Form 35S (socket) and Form 35 (FT21 switchboard): 120-480 V AC. Powered from the meter's voltage connections.
		H Auxiliary Power Pigtail: 65-120 V AC or 80-160 V DC (power from external source)
		J Auxiliary Power Pigtail: 160-277 V AC or 200-300 V DC (power from external source)
		K Auxiliary Power Pigtail: 65-120 V AC, 80-160 V DC (power from external source), Universal Socket Style
		L Auxiliary Power Pigtail: 160-277 V AC, 200-350 V DC (power from external source), Universal Socket Style
		M 1 Infrared optical port, Ethernet (10/100BASE-T), RS-232/485 port, RS-485 port (note: in addition to infrared optical port, Feature Set C can use any two ports (configurable)), 56 k universal internal modem (RJ11)
7	System Frequency	5 Calibrated for 50 Hz systems.
		6 Calibrated for 60 Hz systems.
8	Communications	A 0 Infrared optical port, RS-232/RS-485 port, RS-485 port
		C 7 Infrared optical port, Ethernet (10/100BASE-T), RS-232/485 port, RS-485 port (note: in addition to infrared optical port, Feature Set C can use any two ports (configurable)), 56 k universal internal modem (RJ11)
		E 1 Infrared optical port, Ethernet (10/100BASE-T), RS-232/485 port, RS-485 port (note: in addition to infrared optical port, Feature Set C can use any two ports (configurable))
		F 1 Infrared Optical port, Ethernet (100BASE-FX multi-mode) with male ST connectors (available on socket meters only, Forms 0 & 1 above. I/O card not available if this option is ordered.) RS-232/485 port, RS-485 port (Note: in addition to Infrared Optical port Feature Set C can use any two ports (configurable))
		M 1 Infrared optical port, RS-232/485 port, RS-485 port (note: in addition to infrared optical port, Feature Set C can use any two ports (configurable)), 56 k universal internal modem (RJ11).
		S 1 Infrared optical port, Ethernet (10 BASE-T), RS-232/485 port, RS-485 port (note: in addition to infrared optical port, Feature Set C can use any two ports (configurable)), Verizon 4G LTE cell modem.
9	Onboard I/O	A None.
		B 4 Form C digital outputs, 3 Form A digital inputs.
		C 4 Form C digital outputs, 1 Form A digital output, 1 digital input.
10	Security	0 Password protected no security lock.
		1 Password protected with security lock enabled
		3 RMICAN (Measurement Canada approved)
		4 RMICAN-SEAL (Measurement Canada approved, and factory sealed)
		7 Password protected, no security lock (US only)
		8 Password protected with security lock enabled (US only)
11	Special Order	A None

*Specifications are limited by the operating range of the power supply if a non-aux power supply is used.

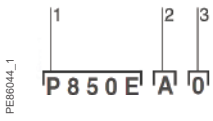

Example order code. Use this group of codes when ordering the I/O Expander.

- 1 Digital / Analog I/O.
- 2 I/O option.
- 3 Cable option.



Commercial reference numbers (cont.)		
I/O Expander		
Digital/Analog I/O	P850E	Schneider Electric I/O Expander for ION8600 meters: Inputs and Outputs for energy pulsing, control, energy counting, status monitoring, and analog interface to SCADA.
I/O option	A	External I/O box with 8 digital inputs and 8 digital outputs (4 Form A, 4 Form C)
	B	External I/O box with 8 digital inputs and 4 digital outputs (4 Form C) and 4 analog outputs (0 to 20 mA)
	C	External I/O box with 8 digital inputs and 4 digital outputs (4 Form C) and 4 analog outputs (-1 mA to 1 mA)
	D	External I/O box with 8 digital inputs and 4 digital outputs (4 Form C) and 4 analog outputs (two -1 to 1 mA, and two 0 to 20 mA outputs)
Cable	0	No cable - cables for the I/O box are no ordered as a separate part number. Refer to commercial reference numbers: CBL-8X00IOE5FT, CBL-8X00IOE15FT and CBL-8XX0-BOP-IOBOX under Connector cables, below.
Comm. ref. no.		
A-base adapters		
A-BASE-ADAPTER-9 Form 9S to Form 9A adapter		
A-BASE-ADAPTER-35 Form 35S to Form 35A adapter		
Optical communication interface		
OPTICAL-PROBE Optical communication interface		
Connector cables		
CBL-8X00BRKOUT 1.5 m extension cable, mates with 24-pin male Molex connector from the meter to the 24-pin Molex connector on the I/O expander box (not for use with breakout panel E8, F8 & G8 form factors)		
CBL-8X00IOE5FT 44.57 m extension cable, mates with 24-pin male Molex connector from the meter to the 24-pin Molex connector on the I/O expander box (not for use with breakout panel E8, F8 & G8 form factors)		
CBL-8X00IOE15FT 44.57 m extension cable, mates with 24-pin male Molex connector from the meter to the 24-pin female Molex connector on the I/O Expander box (not for use with breakout panel E8, F8 & G8 form factors)		
CBL-8XX0-BOP-IOBOX 1.8 m connector cable, 24-pin male to 14-pin male Molex connector for connecting an ION8000 Series meter with breakout panel to an I/O Expander Box		

optimizer

ION8650 socket dimensions

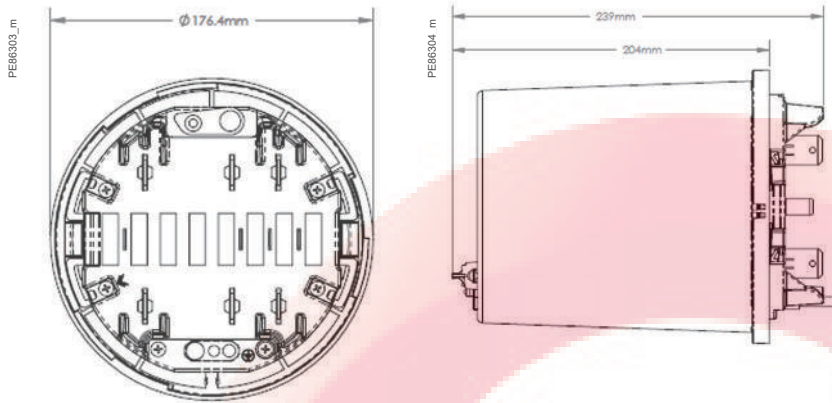

ION8650 switchboard dimensions

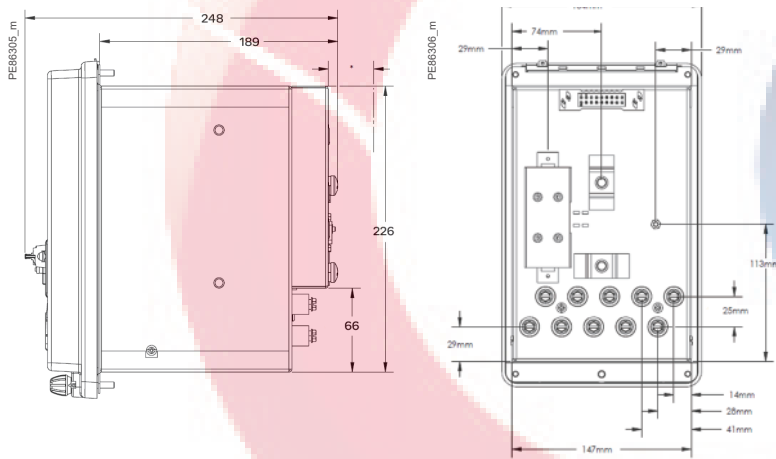

I/O Expander dimensions

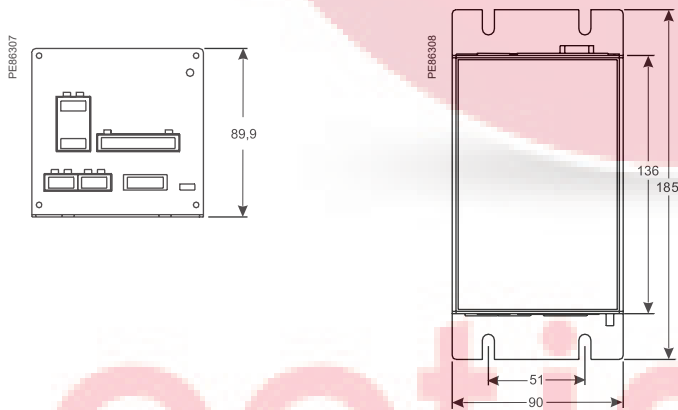

optimizer

ION8650 suggested switchboard mounting dimensions

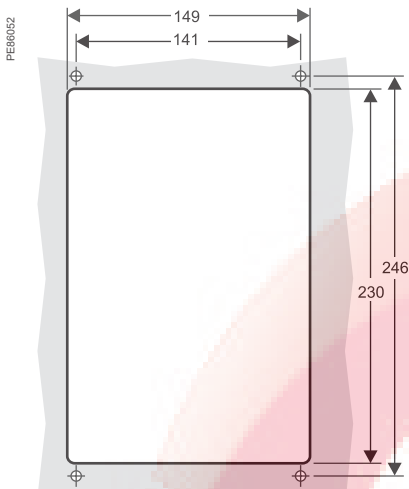

ION8650 switchboard mounting

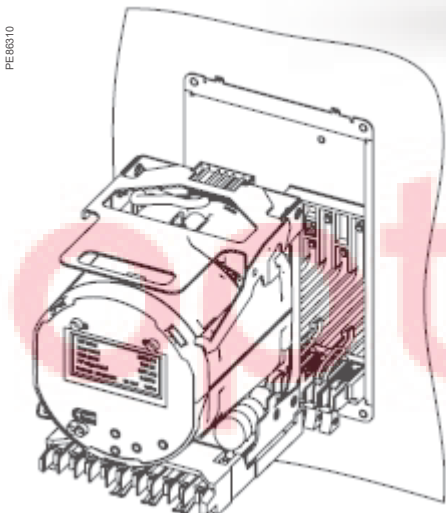
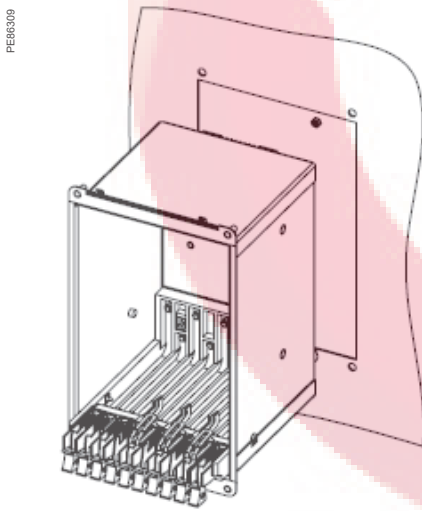

Please see appropriate Installation Guide for these products for further details.

ION8800 series

Providing high accuracy and a wide range of features for transmission and distribution metering, the PowerLogic ION8800 advanced revenue and power quality meter has the flexibility to change along with your needs. The meter provides the tools necessary to:

- Manage energy procurement and supply contracts
- Perform network capacity planning and stability analysis
- Monitor power quality compliance, supply agreements, and regulatory requirements

Applications

- Transmission and distribution metering
- Revenue metering
- Extensive power quality monitoring and analysis
- Power quality compliance monitoring
- Digital fault recording
- Instrument transformer correction



P880CA0A

PE86176

The solution for

Markets that can benefit from a solution that includes PowerLogic ION8800 series meters:

- Transmission networks
- Distribution network

Benefits

- Reduce operations costs
- Improve power quality
- Improve continuity of service

Competitive advantages

- Integrated into existing wholesale settlement system
- Able to use EcoStruxure™ software for data analysis or share operation data with SCADA systems through multiple communication channels and protocols
- Transformer/line loss compensation
- Instrument transformer correction

Power management solutions

Schneider Electric provides innovative power management solutions to increase your energy efficiency and cost savings, maximise electrical network reliability and availability, and optimise electrical asset performance.

Conformity of standards

- IEC 62053-22/23
- IEC 61000-4-3
- IEC 61000-4-30
- IEC 61000-4-4
- EN 50160
- IEC 61000-4-5
- IEC 61000-4-7
- IEC 61000-4-6
- IEC 61000-4-15
- IEC 61000-4-12
- IEEE 1159
- CISPR 22
- IEEE 519
- IEC 62052-11
- IEC 61000-4-2
- IEC 60950

optimizer

Main characteristics

- IEC 19-inch rack mount design to DIN 43862 standard
 - Use Essailec connectors with common measurement and energy pulsing pin-out to easily retrofit into existing systems.
- Accurate metering
 - Interconnection points on medium, high, and ultra-high voltage networks are in compliance with IEC 62053-22/23 Class 0,2S.
- Power quality compliance monitoring
 - Monitor compliance with international quality-of-supply standards (IEC 61000-4-30 Class A/S, EN50160, IEC 61000-4-7, IEC 61000-4-15, IEEE 1159, IEEE 519).
- Power quality summary
 - Consolidate power quality characteristics into easily viewable reports indices.
- Digital fault recording
 - Capture voltage and current channels simultaneously for sub-cycle disturbances.
- Complete communications
 - Use the IEC1107 optical port or the optional communications module that supports concurrent Ethernet, serial, and modem communications.
- Multiple tariffs and time-of-use
 - Apply tariffs and seasonal rate schedules to measure energy and demand values for time periods with specific billing requirements.
- Alarms and I/O functions
 - Use up to 65 setpoints for single/multi-condition alarms and I/O functions with response times down to 1/2 cycle.
- Alarm notification via email
 - High-priority alarms, data logs sent directly to the user's PC. Instant notification of power quality events by email.
- Software integration
 - Easily integrate the meter with EcoStruxure™ Power Monitoring Expert, EcoStruxure™ Power SCADA Operation, or other utility software; MV-90, Pacis and third-party SCADA packages.
- Transformer/line loss compensation
 - Compensate for system losses in real time directly in the meter.
- Instrument transformer correction
 - Save money and improve accuracy by correcting for less accurate transformers.

optimizer

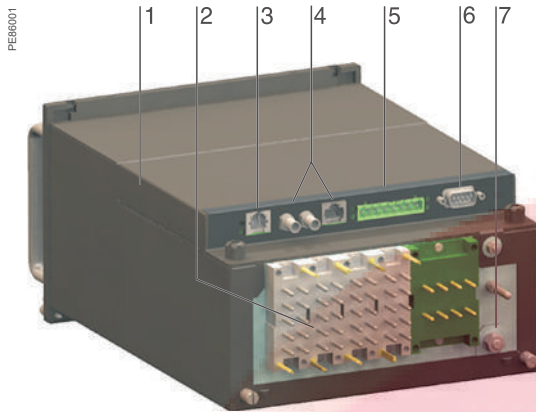

PowerLogic ION8800 meter

- 1 Optional communications module.
- 2 Essailec connectors.
- 3 Internal modem.
- 4 Optional Ethernet communications.
- 5 Selectable RS-485 serial port.
- 6 Selectable RS-232 or RS-485 serial port.
- 7 Ground terminal.

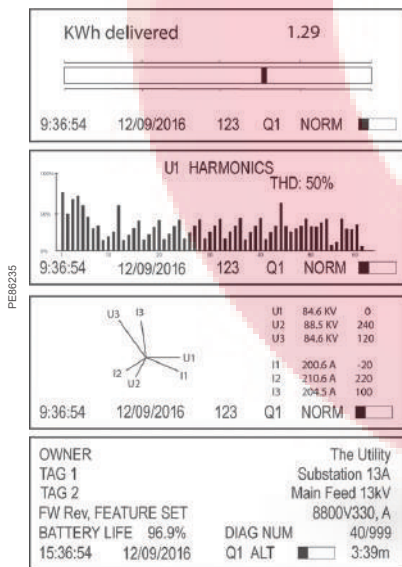

Display screen examples: KWh disk simulator, voltage harmonics histogram, phasor diagram, and name plate1.

Selection guide

	ION8800A ION8800B	ION8800C
General		
Use on LV, MV and HV systems	■	■
Current accuracy	0.1 %	0.1 %
Voltage accuracy	0.1 %	0.1 %
Power accuracy	0.2 %	0.2 %
Samples/cycle	1024	1024
Instantaneous rms values		
Current, voltage, frequency (Class 0,2S)	■	■
Active, reactive, apparent power Total and per phase	■	■
Power factor Total and per phase	■	■
Current measurement range	0.001 - 10 A	0.001 - 10 A
Current measurement range	0.001 - 10 A	0.001 - 10 A
Energy values		
Active, reactive, apparent energy	■	■
Settable accumulation modes	■	■
Demand values		
Current	■	■
Active, reactive, apparent	■	■
Predicted active, reactive, apparent	■	■
Demand modes (block, sliding, thermal, predicted)	■	■
Power quality measurements		
Detection of voltage dips (sags) and swells	10 ms	10 ms
Symmetrical components: zero, positive, negative	■	-
Transient detection, microseconds (50 Hz)	20 ⁽¹⁾	20 ⁽¹⁾
Harmonics: individual, even, odd, total up to	63 rd	63 rd
Harmonics: magnitude, phase and inter-harmonics	50 th	40 th
EN 50160 compliance	■	■
IEC 61000-4-30 class A	■	■
IEC 61000-4-30 class S	■ ⁽²⁾	■
IEC 61000-4-15 (Flicker)	■	-
Configurable for IEEE 519 - 1992, IEEE1159-1995	■ ⁽¹⁾	-
Programmable (logic and math functions)	■	■
Data recording		
Min/max logging for any parameter	■	■
Historical logs	Maximum # of records	960 ⁽¹⁾ 800 ⁽²⁾ 80
Waveform logs	Maximum # of records	96 ⁽¹⁾ 64
Timestamp resolution in seconds	0.001	0.001
Setpoints, minimum response time	½ cycle	½ cycle
Number of setpoints	65	65
GPS time synchronisation (IRIG-B)	■	■
Could add transient logs. COMTRADE fault records.	■	■
User configurable log memory	10 MB	10 MB
Display and I/O		
Front panel display	■	■
Active/reactive energy pulser, LED and IEC 1107 style port	■	■
Digital pulse outputs, optional	Solid state Form A	8 8
Digital pulse outputs	Solid state Form C	4 4
Alarm relay output	Form C	1 1
Digital inputs (optional)	3	3
Communications		
RS-232/485 port	1	1
RS-485 port	1	1
Ethernet port	1	1
IEC 1107 optical port	1	1
Internal modem	1	1
3-port DNP 3.0 through serial, modem, Ethernet and I/R ports	■	■
Modbus RTU master / slave (serial, modem and I/R ports)	■ / ■	- / ■
Modbus TCP master / slave (via Ethernet port)	■ / ■	- / ■
DLMS/COSEM RS-485 port or Ethernet	■	■
Data transfer between Ethernet and RS-485 (EtherGate)	■	■
Data transfer between internal modem, RS-485 (ModemGate)	■	■
Alarms, single or multi-condition	■	■
Alarm notification & logged data via email	■	■
Embedded web server (WebMeter)	■	■

(1) ION8800A only.
(2) ION8800B only.

Part numbers

Item	Code	Description
1	Model	M8800 ION8800 IEC/DIN 43862 19" rack mount energy and power quality meter.
2	Feature Set	A Class A power quality analysis, waveforms and transient capture with 1024 samples/cycle.
		B Energy meter Class S EN50160 power quality monitoring.
		C Basic tariff/energy revenue meter with sag/swell monitoring.
3	Memory/Form Factor	1 10 MB logging memory, Essailec connectors.
		2 5 MB logging memory, Essailec connectors, with IEC61850 protocol
4	Current Inputs	C (I1-I3): Configured for 5 A nominal, 10 A full scale, 14 A fault capture, 0.001 A starting current.
		E (I1-I3): Configured for 1 A nominal, 10 A full scale, 14 A fault capture, 0.001 A starting current.
5	Voltage Inputs	0 (V1-V3): Autoranging (57-288 VAC L-N or 99-500 VAC L-L)
6	Power Supply	B Single phase power supply: 85-240 VAC ±10% (47-63 Hz) or 110-270 VDC.
7	System Frequency	5 Calibrated for 50 Hz systems.
		6 Calibrated for 60 Hz systems.
8	Communications module (field serviceable)	Z0 No communications module - meter includes Base Onboard I/O and comms (see below for details).
		A0 Standard communications: 1 RS 232/RS-485 port, 1 RS-485 port (COM2) ⁽¹⁾ .
		C1 Standard communications plus 10BASE-T Ethernet (RJ45), 56 k universal internal modem (RJ11).
		D1 Standard communications plus 10BASE-T/100BASE-TX Ethernet (RJ45) / 10Base-FL/100BASE-FX Ethernet Fiber, 56 k universal internal modem (RJ11)
		E0 Standard communications plus 10BASE-T/100BASE-TX Ethernet (RJ45).
		F0 Standard communications plus 10BASE-T/100BASE-TX Ethernet (RJ45) / 10Base-FL/100BASE-FX (ST male Fiber Optic connection).
		M1 Standard communications plus 56k universal internal modem (RJ11).
9	Onboard I/O and communications (not field serviceable, part of base unit)	A Base option AND 8 Form A digital outputs ⁽²⁾ , 1 RS-485 (COM2) port ⁽¹⁾ .
		B Base Option AND 8 Form A digital outputs ⁽²⁾ , 3 digital inputs (20-56 VDC/AC).
		C Base Option AND 8 Form A digital outputs ⁽²⁾ , 3 digital inputs (80-280 VDC/AC).
		D Base Option AND 1 IRIG-B time sync port ⁽²⁾ , 1 RS-485 port (COM2), 3 digital inputs (20-56 V DC/AC) ⁽¹⁾ .
		E Base Option AND 1 IRIG-B time sync port ⁽²⁾ , 1 RS-485 port (COM2), 3 digital inputs (80-280 V DC/AC) ⁽¹⁾ .
10	Security	0 Password protected, no security lock.
		1 Password protected with security lock enabled.
11	Special Order	A None.
		C Tropicalisation treatment applied.

Example product part number.

- 1 Model.
- 2 Feature set.
- 3 Memory / form factor.
- 4 Current Inputs.
- 5 Voltage inputs.
- 6 Power supply.
- 7 System frequency.
- 8 Communications.
- 9 Onboard inputs/outputs.
- 10 Security.
- 11 Special order.

M 8 8 0 0 A 1 C 0 A 5 C 1 A 0 A

(1) Channel COM2 is available on the port at the back of the meter OR on the Comm Module (if installed). You must select which connectors your communications wiring is connected to during meter setup.

(2) All Onboard I/O and Comms (Base Option) options include: 4 Form C solid-state digital outputs, 1 Form C mechanical relay output, one IEC 1107 optical communications port, two IEC 1107 style optical pulsing ports.

ION8800 Accessories

Ordering reference	Communication Card for ION8800
P880CA0A	Std. comms: 1 RS-232/RS-485 port, **1 RS-485 port (COM2)
P880CA0C	Std. comms: 1 RS-232/RS-485 port, **1 RS-485 port (COM2), tropicalisation treatment applied
P880CC1A	Std. comms AND 10/1000BASE-TX Ethernet (RJ45), 56k universal internal modem (RJ11)
P880CC1C	Std. comms AND 10/1000BASE-TX Ethernet (RJ45), 56k universal internal modem (RJ11), tropicalisation treatment applied
P880CD1A	Std. comms AND 10/1000BASE-TX Ethernet (RJ45) / 10/100BASE-FX Ethernet Fiber, 56k universal internal modem (RJ11)
P880CD1C	Std. comms AND 10/1000BASE-TX Ethernet (RJ45) / 10/100BASE-FX Ethernet Fiber, 56k universal internal modem (RJ11), tropicalisation treatment applied
P880CE0A	Std. comms AND 10/1000BASE-TX Ethernet (RJ45)
P880CE0C	Std. comms AND 10/1000BASE-TX Ethernet (RJ45), tropicalisation treatment applied
P880CF0A	Std. comms AND 10/1000BASE-TX Ethernet (RJ45) / 10/100BASE-FX (ST Fiber Optic connection)
P880CF0C	Std. comms AND 10/1000BASE-TX Ethernet (RJ45) / 10/100BASE-FX (ST Fiber Optic connection), tropicalisation treatment applied
P880CM1A	Std. comms AND 56k universal internal modem (RJ11)
P880CM1C	Std. comms AND 56k universal internal modem (RJ11), tropicalisation treatment applied
Ordering reference	ION8800 related items
BATT-REPLACE-8XXX	Replacement batteries for the ION8600 or ION8800, quantity 10
RACK-8800-RAW	IEC/DIN 34862 19" Rack with female mating voltage/current and I/O blocks unassembled.
IEC-OPTICAL-PROBE	IEC 61107 compliant Optical Probe (DB-9) for use with ION8800 meters

PE88007_C



Optional ION8800 communications module

ION8800 series

Technical Specification		
Electrical characteristics		
Type of measurement	True rms 1024 samples per cycle	
Measurement accuracy	Current and voltage	0.1 %
	Power	0.2 %
	Frequency	±0.005 Hz
	Power factor	0.1%
	Energy	IEC 62053-22/23 Class 0.2 S
Data update rate	½ cycle or 1 second	
Input-voltage characteristics	Inputs	U1, U2, U3, Uref
	Measurement range	57-288 L-N V AC rms (99-500 L-L V AC rms)
	Dielectric withstand	3320 V AC rms
	Impedance	5 MΩ /phase (phase-Uref/Ground)
Input-current characteristics	Rated nominals	5 A, 1 A, 2 A
	Permissible overload	200A rms for 0.5s, non-recurring (IEC 62053-22)
	Impedance	10 mΩ /phase
	Burden	0.01 VA per phase (1A), 0.25 VA per phase (5 A)
Power supply	AC	85 - 240 V AC (+/- 10 %), 47-63 Hz
	DC	110 - 270 V DC (+/- 10 %)
	Burden	Typical (without comm module): 13 VA, 8 W Max (without comm module): 24 VA, 10 W Typical (with comm module): 19 VA, 12 W Max (with comm module): 32 VA, 14 W
	Ride-through time	Typical: 0.5 s to 5 s depending on configuration Min: 120 ms (6 cycles @ 50 Hz)
	Dielectric withstand	2000 V AC
Input/outputs	Mechanical alarm relay	1 Form C digital output (250 V AC / 125 V DC, 1 A AC / 0.1 A DC max)
	Digital outputs (Form C)	4 Solid state relay outputs (210 V AC / 250 V DC) 100 mA AC/DC
	Digital outputs (Form A)	8 Solid state relay outputs (210 V AC / 250 V DC) 100 mA AC/DC
	Digital inputs	3 Solid state digital inputs (low-voltage inputs 15 to 75 V AC/DC; high-voltage inputs 75 to 280 V AC/DC; 3 mA max.)
	Pulse rate	20 Hz maximum
Mechanical characteristics		
Weight	6.0 kg (6.5 kg with optional communications module)	
IP degree of protection (IEC 60529)	IP51	
Dimensions	202.1 x 261.51 x 132.2 mm	
Environmental conditions		
Mounting location	Indoor	
Maximum altitude	2000 metres above sea-level	
Limit range of operation	-25 °C to 70 °C	
Specified operating temperature	-10 °C to 45 °C (as per 62052-11)	
Display operating range	-10 °C to 60 °C	
Storage temperature	-25 °C to 70 °C	
Humidity rating	5 to 95 % RH non-condensing	
Pollution degree	2	
Installation category	Power supply (II) Metering inputs (III)	
Electromagnetic compatibility		
Electrostatic discharge	IEC 61000-4-2	
Immunity to radiated fields	IEC 61000-4-3	
Immunity to fast transients	IEC 61000-4-4	
Immunity to surge waves	IEC 61000-4-5	
Conducted immunity	IEC 61000-4-6	
Damped oscillatory waves immunity	IEC 61000-4-12	
Conducted and radiated emissions	CISPR 22 (class B)	
Safety		
Europe	As per IEC 62052-11	
International	As per IEC 60950	

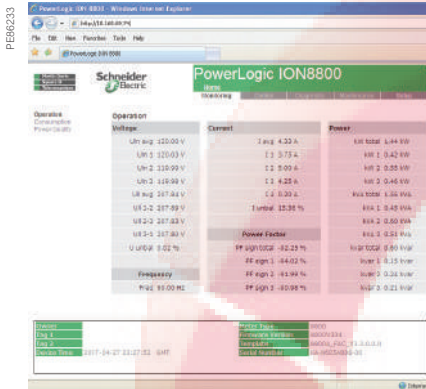
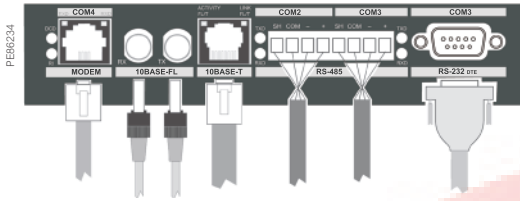

Ports on the optional communications module.

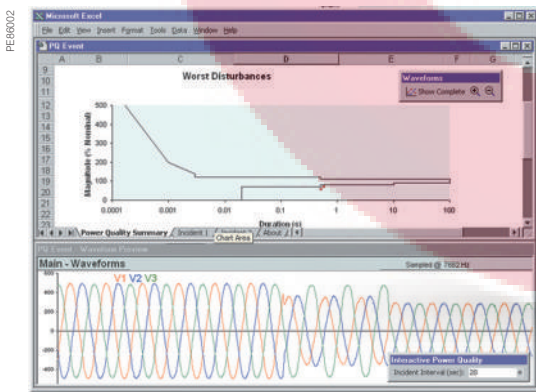

Example embedded page showing realtime values.

Technical Specification

Communication	
IEC 1107 optical port	2/4 wires, up to 19200 baud
RS-485 port	Up to 57600 baud, direct connection to a PC or modem, protocols: ION, Modbus RTU, Modbus Master, DNP 3.0, GPSTRUETIME/DATUM, DLMS/COSEM
Communications module (optional)	
RS-232/485 port	300 - 115,200 baud (RS-485 limited to 57,600 baud); protocols: same as RS-485 port
Internal modem port	300 baud - 56000 baud, RJ11 connector
Ethernet port	10/100BASE-TX, RJ45 connector, 100 m link; protocols: DNP TCP, ION, Modbus TCP, Modbus Master, DLMS/COSEM, IEC 61850
Fiber-optic Ethernet link	10/100BASE-FX, ST connector, 1300 nm, FO multimode with gradient index 62.5/125 µm or 50/125 µm, 2000 m link; protocols: same as Ethernet port
EtherGate	Communicates directly with up to 62 slave devices via available serial ports
ModemGate	Communicates directly with up to 31 slave devices
Firmware characteristics	
High-speed data recording	Up to ½-cycle interval burst recording, stores detailed characteristics of disturbances or outages Trigger recording by a user-defined setpoint, or from external equipment.
Harmonic distortion	Up to 63 rd harmonic for all voltage and current inputs
Dip/swell detection	Analyse severity/potential impact of sags and swells: magnitude and duration data suitable for plotting on voltage tolerance curves per phase triggers for waveform recording or control operations
Instantaneous	High accuracy measurements with 1s or 1/2 cycle update rate for: voltage and current active power (kW) and reactive power (kvar) apparent power (kVA) power factor and frequency voltage and current unbalance phase reversal
Load profiling	Channel assignments (800 channels via 50 data recorders) are configurable for any measurable parameter, including historical trend recording of energy, demand, voltage, current, power quality, or any measured parameter Trigger recorders based on time interval, calendar schedule, alarm/event condition, or manually.
Modbus Master	Master up to 32 slave devices per serial channel and store their data at programmable intervals. Use this data to aggregate and sum energy values and perform complex totaling.
Waveform captures	Simultaneous capture of all voltage and current channels sub-cycle disturbance capture maximum cycles is 214,000 (16 samples/cycle x 96 cycles, 10 MB memory) 1024 samples/cycle
Alarms	Threshold alarms: adjustable pickup and dropout setpoints and time delays, numerous activation levels possible for a given type of alarm user-defined priority levels boolean combination of alarms possible
Advanced security	Up to 50 users with unique access rights. Perform resets, time syncs, or meter configurations based on user privileges.
Transformer correction	Correct for phase / magnitude inaccuracies in current transformers (CTs), potential transformers (PTs)
Memory	5 -10 MB(specified at time of order)
Firmware update	Update via the communication ports
Display characteristics	
Type	FSTN transreflective LCD
Backlight	LED
Languages	English

ION8800 dimensions

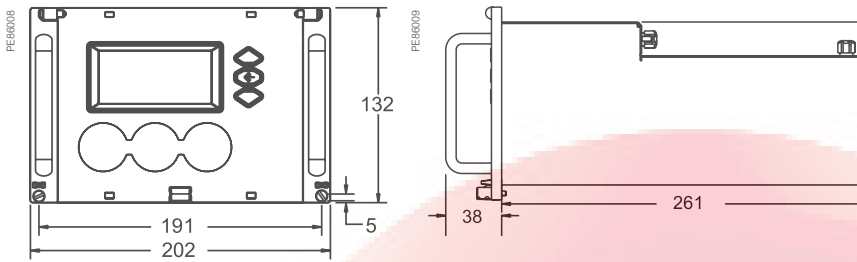

ION8800 Essailec rack dimensions

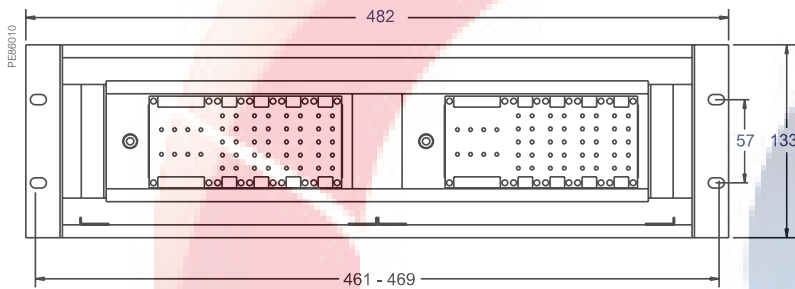

Rack mounting the ION8800

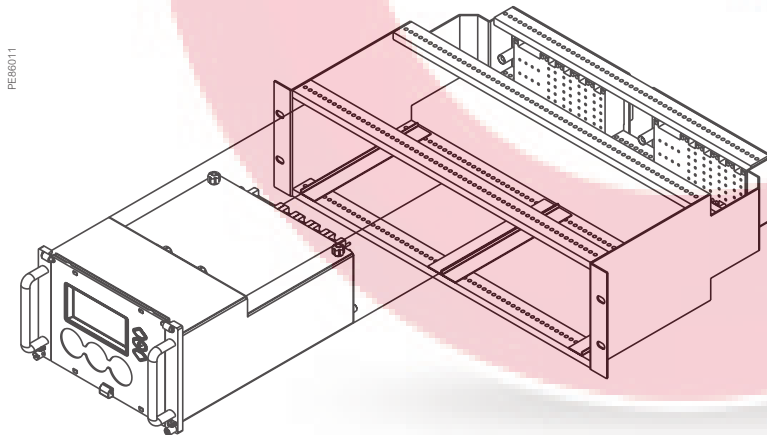

ION8800 communication module dimensions

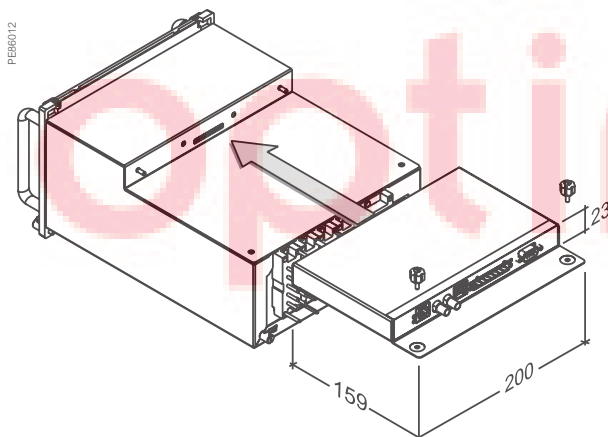

Please see the appropriate **Installation Guide** for accurate and complete information on the installation of this product.

Multi-circuit metering

This is an integrated solution for monitoring multi-circuits and mains by using a single meter. The meter is designed for use in both new build and retrofit and is used for critical power operations in data centres and energy management in buildings.

The ideal solution for data centre managers, energy or facility managers, engineers and operational executives who are responsible for delivering power to critical applications.

In corporate and hosted data centre facilities, this technology helps you plan and optimise the critical power infrastructure to meet the demands of continuous availability.

- PowerLogic BCPM
- EM4000 Series
- EM4800
- EM4900

PB113665 PE86325 PB113664



BCPMA084S



BCPMA042S



BCPMA084S

PowerLogic BCPM

The PowerLogic BCPM is a highly accurate, full-featured metering product designed for the unique, multi-circuit and minimal space requirements of a high performance power distribution unit (PDU) or remote power panel (RPP).

It offers class 1 (1 %) power and energy system accuracy (including 50 A or 100 A CTs) on all branch channels. The BCPM monitors up to 84 branch circuits and the incoming power mains to provide information on a complete PDU. Full alarming capabilities ensure that potential issues are dealt with before they become problems.

Applications

- Maximise uptime and avoid outages
- Optimise existing infrastructure
- Improve power distribution efficiency
- Track usage and allocate energy costs
- Enable accurate sub-metering

PB 113086



BCPMA084S

The solution for

Markets that can benefit from a solution that includes PowerLogic BCPM series meters:

- Data centres
- Buildings

Benefits

The flexible BCPM fits any PDU or RPP design and supports both new and retrofit installations. It has exceptional dynamic range and accuracy, and optional feature sets to meet the energy challenges of mission critical data centres.

Competitive advantages

- Fit any PDU or RPP design for both new and retrofit projects
- Class 1.0 system accuracy
- Ethernet communication

Power management solutions

Schneider Electric provides innovative power management solutions to increase your energy efficiency and cost savings, maximise electrical network reliability and availability, and optimise electrical asset performance.

Conformity of standards

- ANSI C12.1
- IEC 61010-1
- IEC 62053-21 Class 1
- UL508

optimizer

BCPM

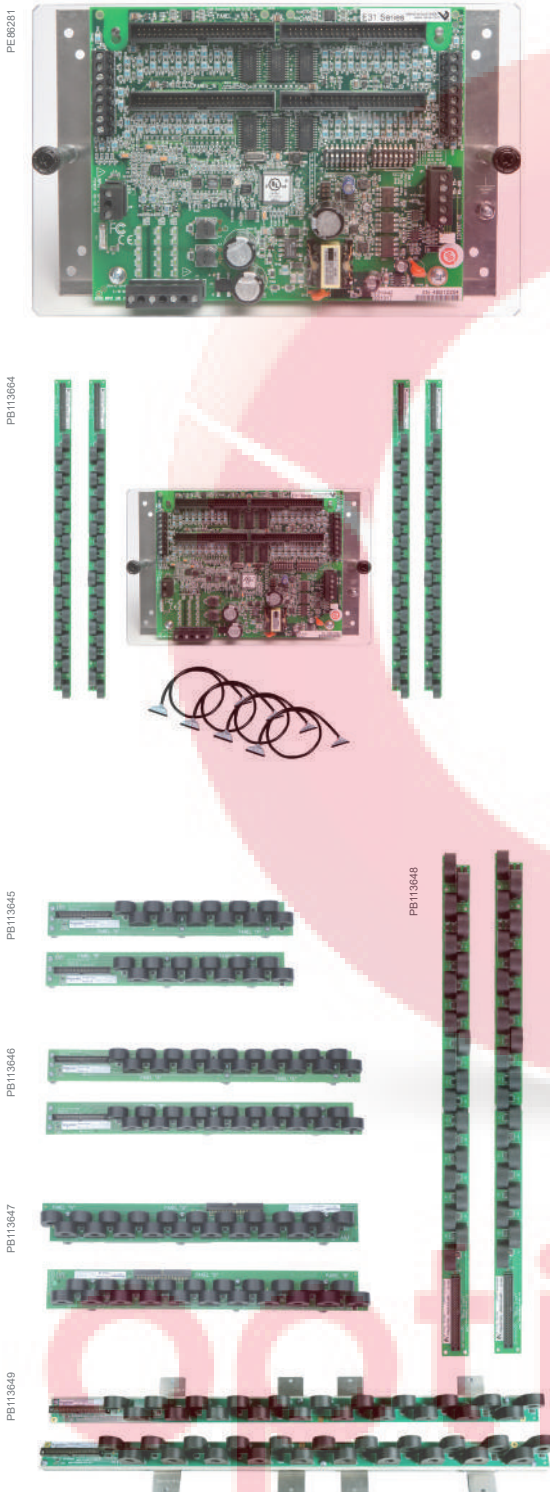

Main characteristics

- Monitor up to 84 branch circuits with a single BCPM.
- Ideal for installation in both new PDUs and retrofit projects
- New installations:
 - BCPM with solid core CTs monitors up to 84 branch circuits using 2 or 4 CT strips. Solid core CTs are rated to 100 A CTs and are mounted on strips to simplify installation. CT strips are available with 12, 18 or 21 CTs per strip on 18 mm spacings. 21 CT strips with 3/4in or 1in spacings are also available.
- Retrofit projects:
 - BCPMSC with split-core CTs is ideal for retrofits. Any number of split-core CTs, up to 84 maximum, can be installed with a single BCPM. Three sizes of CT are supported (50 A, 100 A, and 200 A) and all three CT sizes can be used on a single BCPM. Adapter boards with terminals for split-core CTs can be mounted using DIN-rail, Snaptrack or on a common mounting plate with the main board (42 ch Y63 models only).
- IEC Class 1 metering accuracy
 - Accurately monitor very low current levels, down to a quarter-Amp.
 - Easily differentiate between the flow of low current and a trip where no current flows.
- Class 1.0 system accuracy for Revenue Grade measurements
 - Branch Power and Energy measurements fully meet ANSI and IEC class 1 accuracy requirements with 50 or 100 A CTs included. No need to de-rate meter branch accuracy to allow for CTs. Voltage and current measurement accuracy is 0.5 % and currents are measured down to 50mA. Easily differentiate between the flow of low current and a trip where no current flows.
 - Class 1.0 system accuracy for Revenue Grade measurements
 - Branch Power and Energy measurements fully meet ANSI and IEC class 1 accuracy require
- Power quality: obtain basic power quality data thanks to the measurement of Total Harmonic Distortion percentages on voltages and current. (V L-L, V L-N, I L-N).
- Designed to fit any PDU or RPP design
 - Lowers your total installation costs as well as the cost per meter point by supporting both new and retrofit installations.
- Communicates with your various systems: BCPMA, and BCPMSCA have a Modbus RTU connection BCPME, and BCPMSCE, have a serial connection for either Modbus RTU or BACnet MS/TP. And there is an ethernet connection for Modbus TCP, BACnet IP and SNMP at the same time. Allowing the concurrent use of an Energy Management System, a Building Management System and an IT system.
- Compatible with PowerLogic power monitoring software
 - Easily turn the large amount of data collected by the devices into useful decision-making information.
- Flexible Configuration capability
 - Set the ordering and orientation of CT strips, assign individual CT size and phases, support for 1, 2, and 3-pole breakers in any configuration.

BCPM

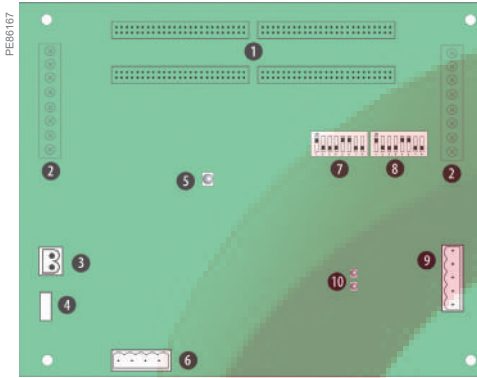

- PowerLogic BCPM
- 1 50-pin ribbon cable connectors (data acquisition board).
 - 2 Auxiliary inputs.
 - 3 Control (mains) power connection.
 - 4 Control power fuse.
 - 5 Alive LED.
 - 6 Voltage taps.
 - 7 Communications address DIP switches.
 - 8 Communications settings DIP switch.
 - 9 RS-485 2 connection.
 - 10 RS-485 LEDs.

Feature selection		BCPMA	BCPME
General			
Use on LV systems		■	■
Power and energy measurements			
Mains		■	■
Branch circuits		■	■
Instantaneous rms values			
Voltage, frequency		■	■
Current		■	■
Active power	Total and per phase	■	■
Power factor	Total and per phase	■	■
Energy values			
Active energy		■	■
Demand values			
Total active power	Present and max. values	■	■
Power quality measurements			
THD % (V L-L, V L-N, I L-N)		■	■
Detection of over-voltage/under-voltage		■	■
Sampling rate points per cycle		2560 Hz	2560 Hz
Alarming			
Alarms		■	■
Power supply			
AC version		90-277 V AC	100-277 V AC
Communication			
RS-485 port		■	■
Modbus RTU		RTU	■
Modbus TCP		1★	■
BACnet IP		1★	■
BACnet MS/TP		1★	■
SNMP protocol		1★	■
Ethernet Port		1★	■

★1 Add E8951 Gateway

optimizer

BCPM



Example BCPM with solid core CTs part number

1. Model
2. Feature set
3. CT spacing (solid core models only)
4. Number of circuits
5. Brand

The PowerLogic BCPM uses .333 V AC output split-core CTs for the auxiliary inputs. These CTs are ordered separately from the BCPM.

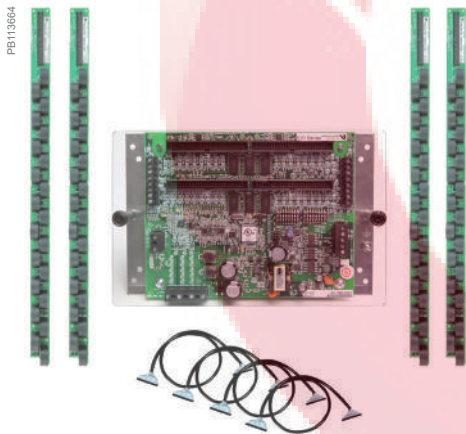

BCPM part numbers

BCPM with solid core CTs			
Item		Code	Description
1	Model	BCPM	BCPM with solid core CTs. Highly accurate meter that monitors branch circuits and the incoming power mains and includes full alarming capabilities
2	Feature set	A	Advanced - Monitors power & energy per circuit & mains, Modbus RTU only (add E8951 for other protocols), Meter Main Board comes on an aluminum mounting plate
		E	Advanced, with Ethernet - Monitors power & energy per circuit & mains, Meter Main Board is partially enclosed in a metal housing
3	CT spacing	0	3/4in (19 mm) CT spacing
		1	1in (26 mm) CT spacing
		2	18 mm CT spacing
4	Number of circuits	24	24 circuits, (2) 12-CT strips (18 mm spacing only)
		36	36 circuits, (2) 18-CT strips (18 mm spacing only)
		42	42 circuits, (2) 21-CT strips
		48	48 circuits, (4) 12-CT strips (18 mm spacing only)
		72	72 circuits, (4) 18-CT strips (18 mm spacing only)
		84	84 circuits, (4) 21-CT strips
5	Brand	S	Schneider Electric

* Quantity and style of CT strips and cables included varies by model

BCPM

PB113735



Example BCPMSC with split-core CTs part number.

- 1 Model.
- 2 Feature set.
- 3 Number of circuits.
- 4 Brand.

PB113666

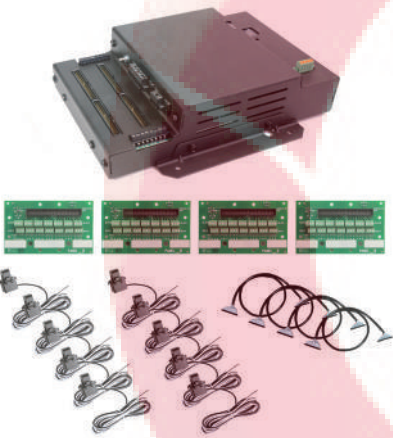

PB113730

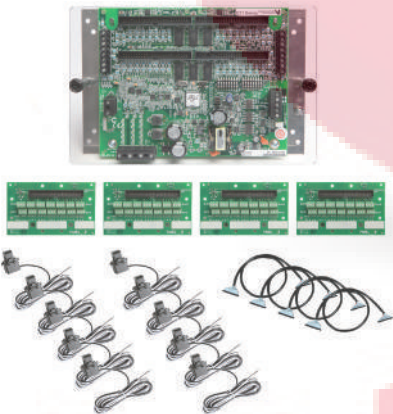

BCPM part numbers (contd.)

		BCPM with split-core CTs	BCPM with split-core CTs
1	Model	BCPMSC	BCPM with split-core CTs. Highly accurate meter that monitors branch circuits and the incoming power mains and includes full alarming capabilities
2	Feature set	A	Advanced - Monitors power and energy per circuit and mains, Modbus RTU only (add E8951 for other protocols), Meter Main Board comes on an aluminum mounting plate
		B	Intermediate - Monitors current per circuit, power and energy per mains, Modbus RTU only (add E8951 for other protocols), Meter Main Board comes on an aluminum mounting plate
		C	Basic - Monitors current only per circuit and mains, Modbus RTU only (add E8951 for other protocols), Meter Main Board comes on an aluminum mounting plate
		E	Advanced, with Ethernet - Monitors power & energy per circuit & mains, Meter Main Board is enclosed in a metal housing
3	Number of circuits	1	42 circuit main and adapter boards (no branch CTs or ribbon cables, order separately)
		2	84 circuit main and adapter boards (no branch CTs or ribbon cables, order separately)
		30	30 split-core CTs (50 A)
		42	42 split-core CTs (50 A)
		60	60 split-core CTs (50 A)
		84	84 split-core CTs (50 A)
		Y63	42 circuits – main and adapter boards on single mounting plate (no branch CTs or ribbon, order separately) - Feature set A only
4	Brand	S	Schneider Electric

*The BCPMSC models with 1, 2 or Y63 as the number of circuits DO NOT INCLUDE ANY branch CTs or ribbon cables (they include only the Main board and adapter board assemblies). These models are provided to allow users to order a specific combination of CT quantities, CT sizes, CT lead lengths and ribbon cable styles and lengths. The CTs and cables must be ordered separately.

The PowerLogic BCPMSC uses .333 V AC output split-core CTs for the auxiliary inputs. These CTs are ordered separately from the BCPMSC.

optimizer

BCPM

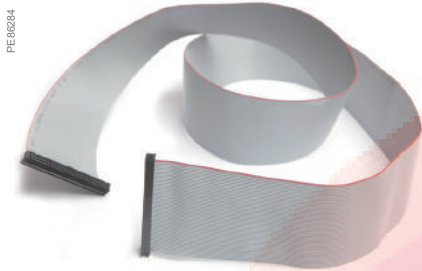

Flat ribbon cable



CBL016

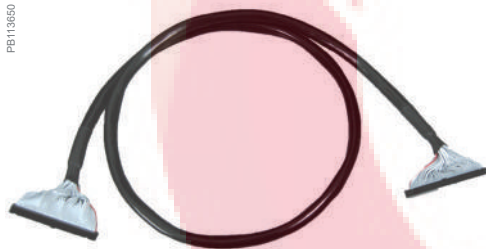

Round ribbon cable



CBL022

BCPM part numbers for solid and split-core CTs (contd.)

BCPM with split-core CTs	
Commercial ref. no.	Description
BCPMA042S	42-circuit solid core power & energy meter, 100 A CTs (2 strips), 19 mm spacing
BCPMA084S	84-circuit solid core power & energy meter, 100 A CTs (4 strips), 19 mm spacing
BCPMA142S	42-circuit solid core power & energy meter, 100 A CTs (2 strips), 25 mm spacing
BCPMA184S	84-circuit solid core power & energy meter, 100 A CTs (4 strips), 25 mm spacing
BCPMA224S	24-circuit solid core power & energy meter, 100 A CTs (2 strips), 18 mm spacing
BCPMA236S	36-circuit solid core power & energy meter, 100 A CTs (2 strips), 18 mm spacing
BCPMA242S	42-circuit solid core power & energy meter, 100 A CTs (2 strips), 18 mm spacing
BCPMA248S	48-circuit solid core power & energy meter, 100 A CTs (4 strips), 18 mm spacing
BCPMA272S	72-circuit solid core power & energy meter, 100 A CTs (4 strips), 18 mm spacing
BCPMA284S	84-circuit solid core power & energy meter, 100 A CTs (4 strips), 18 mm spacing
BCPME042S	42-circuit solid core power & energy meter w/Ethernet, 100 A CTs (2 strips), 19 mm spacing
BCPME084S	84-circuit solid core power & energy meter w/Ethernet, 100 A CTs (4 strips), 19 mm spacing
BCPME142S	42-circuit solid core power & energy meter w/Ethernet, 100 A CTs (2 strips), 25 mm spacing
BCPME184S	84-circuit solid core power & energy meter w/Ethernet, 100 A CTs (4 strips), 25 mm spacing
BCPME224S	24-circuit solid core power & energy meter w/Ethernet, 100 A CTs (2 strips), 18 mm spacing
BCPME236S	36-circuit solid core power & energy meter w/Ethernet, 100 A CTs (2 strips), 18 mm spacing
BCPME242S	42-circuit solid core power & energy meter w/Ethernet, 100 A CTs (2 strips), 18 mm spacing
BCPME248S	48-circuit solid core power & energy meter w/Ethernet, 100 A CTs (4 strips), 18 mm spacing
BCPME272S	72-circuit solid core power & energy meter w/Ethernet, 100 A CTs (4 strips), 18 mm spacing
BCPME284S	84-circuit solid core power & energy meter w/Ethernet, 100 A CTs (4 strips), 18 mm spacing

Cabling and connection

Flat ribbon cables are recommended for use when the BCPM printed circuit board will be mounted inside of the PDU that is being monitored. Round ribbon cables are the preferred choice when the ribbon cable will be threaded through conduit.

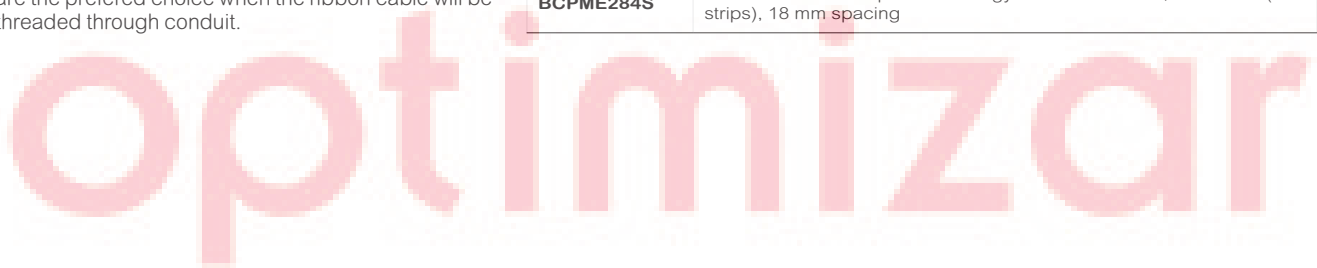

BCPM



PB113651



BCPMSCA1S

BCPMSCxY63S 42-circuit split-core models come with the main board, (2) adapter boards and ribbon cables all mounted on a backplate, to simplify installation.

PE86183



LVCT00050S

PowerLogic™ LVCT0xxxS Split-core Low-voltage (1/3V) CTs for Aux inputs (Mains) are ideal for retrofit applications

PB113652



PB113657

PB113658



LVCT20050S

PowerLogic™ LVCT2xxxS Low-voltage (1/3V) solid core CTs for Aux inputs (Mains) are ideal for panel builders (small, medium, large)

BCPM part numbers for solid and split-core CTs (contd.)

BCPM with split-core CTs

Commercial ref. no.	Description
BCPMSCA1S	42-circuit split-core power and energy meter, CTs and cables sold separately
BCPMSCA2S	84-circuit split-core power and energy meter, CTs and cables sold separately
BCPMSCA30S	30-circuit split-core power and energy meter, (30) 50 A CTs & (2) 1.2 m cables
BCPMSCA42S	42-circuit split-core power and energy meter, (42) 50 A CTs & (2) 1.2 m cables
BCPMSCA60S	60-circuit split-core power and energy meter, (60) 50 A CTs & (4) 1.2 m cables
BCPMSCAY63S	42-circuit split-core power and energy meter, all boards on backplate, CTs and cables sold separately
BCPMSCA84S	84-circuit split-core power and energy meter, with (84) 50 A CTs & (4) 1.2 m cables
BCPMSCE1S	42-circuit split-core power and energy meter w/Ethernet, CTs and cables sold separately
BCPMSCE2S	84-circuit split-core power and energy meter w/Ethernet, CTs and cables sold separately
BCPMSCE30S	30-circuit split-core power and energy meter w/Ethernet, (30) 50 A CTs & (2) 1.2 m cables
BCPMSCE42S	42-circuit split-core power and energy meter w/Ethernet, (42) 50 A CTs & (2) 1.2 m cables
BCPMSCE60S	60-circuit split-core power and energy meter w/Ethernet, (60) 50 A CTs & (4) 1.2 m cables
BCPMSCE84S	84-circuit split-core power and energy meter w/Ethernet, (84) 50 A CTs & (4) 1.2 m cables

The PowerLogic™ BCPM uses .333 V AC output split-core CTs for the auxiliary inputs. These CTs are ordered separately from the BCPM.

BCPM

Commercial ref. no.		
BCPM split-core branch CTs and adapter boards		
BCPMSCADPBS	BCPM adapter boards, quantity 2, for split-core BCPM	
BCPMSCCT0	BCPM 50 A split-core CTs, Quantity 6, 1.8 m lead lengths	
BCPMSCCT0R20	BCPM 50 A split-core CTs, quantity 6, 6 m lead lengths	
BCPMSCCT1	BCPM 100 A split-core CTs, Quantity 6, 1.8 m lead lengths	
BCPMSCCT1R20	BCPM 100 A split-core CTs, Quantity 6, 6 m lead lengths	
BCPMSCCT3	BCPM 200 A split-core CTs, Quantity 1, 1.8 m lead lengths	
BCPMSCCT3R20	BCPM 200 A split-core CTs, Quantity 1, 6 m lead lengths	
Commercial ref. no.		
Additional accessories for use with BCPM products		
BCPMCOVERS	BCPM circuit board cover	
BCPMREPAIR	CT repair kit for solid core BCPM (includes one CT)	
H6803R-0100	Additional 100 A split-core CT for use with solid core repair kit	
E8951	Modbus to BACnet protocol converter	
CBL016	Flat Ribbon cable (quantity 1) for BCPM, length = 1.2 m	
CBL017	Flat Ribbon cable (quantity 1) for BCPM, length = 1.5 m	
CBL018	Flat Ribbon cable (quantity 1) for BCPM, length = 1.8 m	
CBL020	Flat Ribbon cable (quantity 1) for BCPM, length = 3.0 m	
CBL021	Flat Ribbon cable (quantity 1) for BCPM, length = 6.1 m	
CBL022	Round Ribbon cable (quantity 1) for BCPM, length = 1.2 m	
CBL024	Round Ribbon cable (quantity 1) for BCPM, length = 6.1 m	
1/3 V low-voltage Split-core CTs for Aux inputs (Mains)		
Commercial ref. no.	Amperage rating	Inside dimensions
LVCT00050S	50 A	10 mm x 11 mm
LVCT00101S	100 A	16 mm x 20 mm
LVCT00202S	200 A	32 mm x 32 mm
LVCT00102S	100 A	30 mm x 31 mm
LVCT00202S	200 A	30 mm x 31 mm
LVCT00302S	300 A	30 mm x 31 mm
LVCT00403S	400 A	62 mm x 73 mm
LVCT00603S	600 A	62 mm x 73 mm
LVCT00803S	800 A	62 mm x 73 mm
LVCT00804S	800 A	62 mm x 139 mm
LVCT01004S	1000 A	62 mm x 139 mm
LVCT01204S	1200 A	62 mm x 139 mm
LVCT01604S	1600 A	62 mm x 139 mm
LVCT02004S	2000 A	62 mm x 139 mm
LVCT02404S	2400 A	62 mm x 139 mm
1/3 V low-voltage Solid core CTs for Aux inputs (Mains)		
Commercial ref. no.	Amperage rating	Inside dimensions
LVCT20050S	50 A	10 mm
LVCT20100S	100 A	10 mm
LVCT20202S	200 A	25 mm
LVCT20403S	400 A	31 mm

BCPM

Technical specifications		
Electrical characteristics		
Type of measurement		
Accuracy	Power/energy	1 % system accuracy (including 50A or 100A branch CTs)
	Voltage	±0.5 % of reading
	Current	±0.5 % of reading
Minimum "ON" current		50mA
Sampling rate Points per cycle		2560 Hz
Data update rate		1.8 seconds (Modbus), 14 seconds (BACnet) 20 sec (SNMP)
Input-voltage characteristics	Measured voltage	150 – 480 V AC L-L ⁽¹⁾ 90 – 277 V AC L-N ⁽¹⁾
	Measurement range	150 – 480 V AC L-L ⁽¹⁾ 90 – 277 V AC L-N ⁽¹⁾
Power supply	AC	100 – 277 V AC (50/60 Hz)
Auxiliary CT Current Input Range		0-0.333V; CTs must be rated for use with Class 1 voltage inputs
Mechanical characteristics		
Weight		1.5 kg
Dimensions	A/B/C model Circuit board	288 x 146 mm
E model housing (w/brackets on long sides)		253 mm W x 307 mm H x 71 mm D
E model housing (w/brackets on short ends)		210 mm W x 353 mm H x 71 mm D
Environmental conditions		
Operating temperature	0 to 60 °C	
Storage temperature	-40 °C to 70 °C	
Installation category	CAT III, pollution degree 2	
Safety		
Europe	IEC 61010	
U.S. and Canada	UL 508 Open type device	
Communication		
RS-485 (A/B/C models)	Baud rate: DIP-switch selectable 9600, 19200, 38400 DIP-switch selectable 2-wire or 4-wire RS-485. Parity selectable: Even, Odd or None.	
RS-485 (A models)	Baud rate: configured via Web-server. Baud selectable: 9600, 19200, 38400. Parity selectable: Even, Odd or None. 2-wire RS-485.	
Ethernet (E models)	10/100 Mbit Ethernet. RJ-45 connection. Static IP or DHCP.	
Protocols	Modbus RTU on all models, BCPME models also support Modbus TCP, SNMP, BACnet IP & BACnet MS/TP	
Firmware characteristics		
Detection of over-voltage/under-voltage	User-defined alarm thresholds for over-voltage and under-voltage detection	
Alarms	Four alarm levels: high-high, high, low and low-low (users define the setpoints for each). Each alarm has a latching status to alert the operator that an alarm has previously occurred. High and Low alarms have instantaneous status to let the operator know if the alarm state is still occurring.	
Firmware update	Update via Modbus	

BCPM

1/3 V low-voltage CT (LVCT) for Mains - Technical specifications

Electrical characteristics	
Accuracy	1 % from 10 % to 100 % of rated current(LVCT0xxx0S/1S/2S/3S/4S [split-core]) 0.5 % from 5 % to 100 % of rated current (LVCT2xxx0S/2S/3S [solid core])
Frequency range	50/60 Hz
Leads	18 AWG, 600 V AC, 1.8m standard length
Max. voltage L-N sensed conductor	300 V AC (LVCT0xxx0S) 600 V AC (LVCT0xxx1S/2S/3S/4S, LVCT2xxxxS)
Environmental conditions	
Operating temperature	0 °C to 70 °C (LVCT0xxx0S/1S) -15 °C to 60 °C (LVCT0xxx2S/3S/4S less than 2400A) -15 °C to 60 °C (LVCT02404S [2400A]) -40 °C to 85 °C (LVCT2xxx0S/2S/3S [solid core])
Storage temperature	-40 °C to 105 °C (LVCT0xxx0S/1S) -40 °C to 70 °C (LVCT0xxx2S/3S/4S) -50 °C to 105 °C (LVCT2xxx0S/2S/3S [solid core])
Humidity range	0 to 95 % non-condensing



optimizer

BCPM

PowerLogic BCPM dimensions

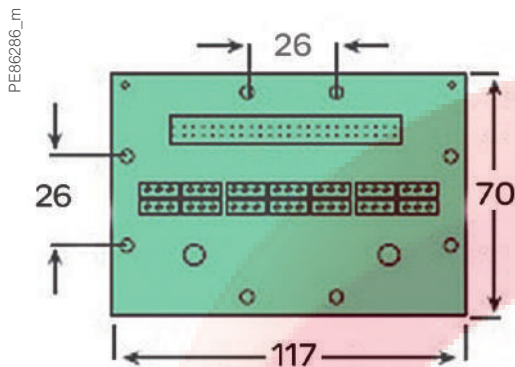

PowerLogic BCPM adapter board (one board per 21 split-core branch CTs)

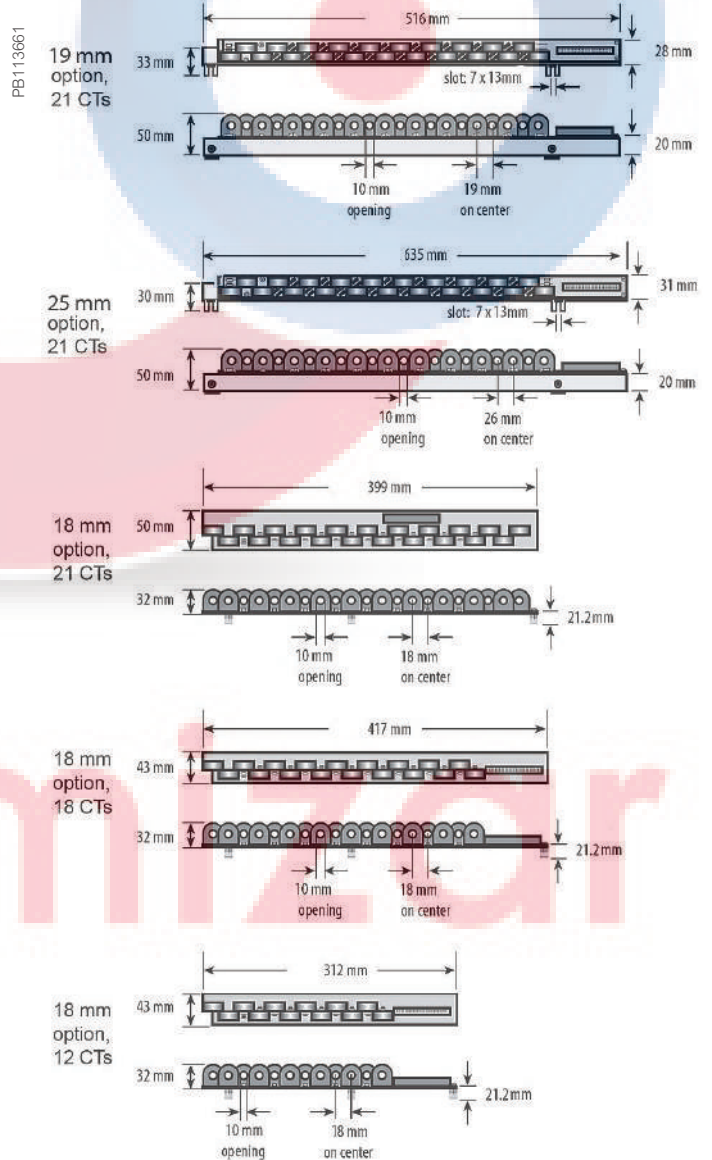
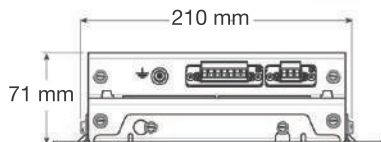
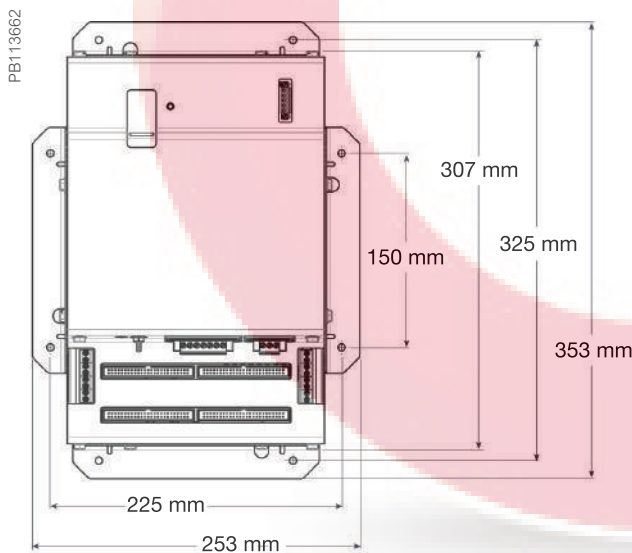
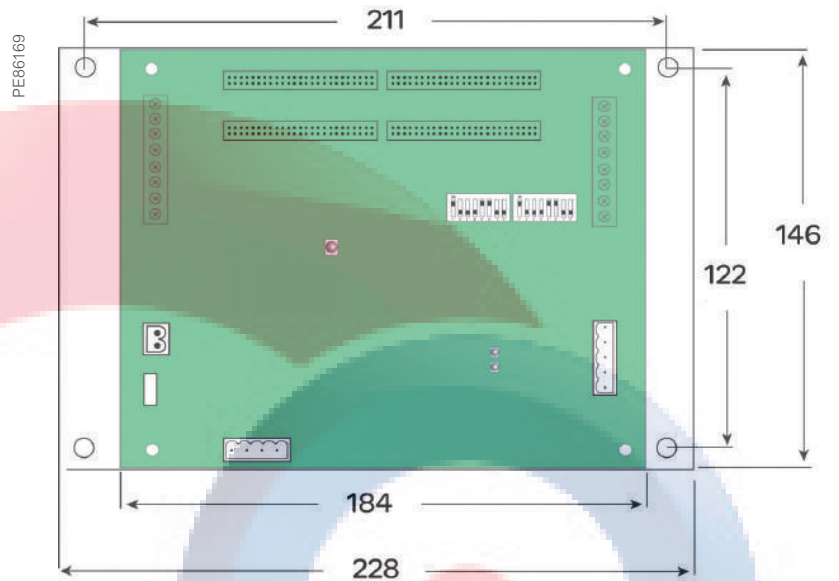

BCPM

50 A-200 A Split-core CT dimensions

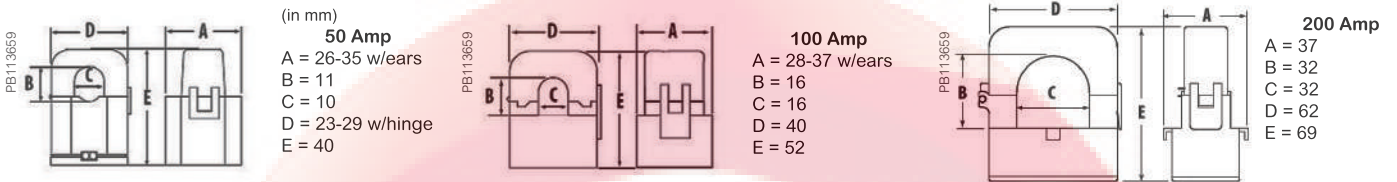

These dimensions apply to both BCPMSCCTxx (branch CTs) and LVCT0xxxx0S/1S (for Mains) 50 A-200 A CT families.

Solid core CT dimensions

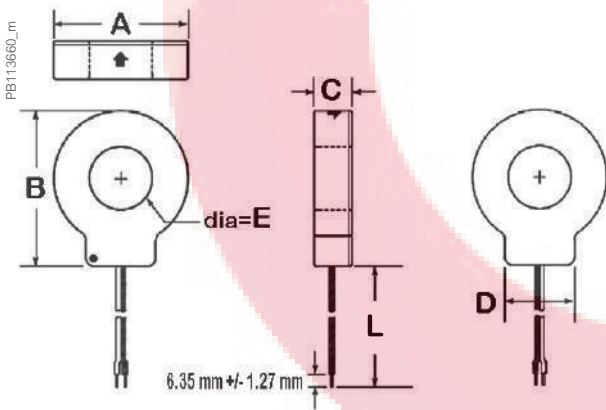

Model	L	A	B	C	D	E
LVCT20050S	1.8 m	33 mm	38 mm	18 mm	21 mm	10 mm
LVCT20100S		59 mm	66 mm	18 mm	31 mm	25 mm
LVCT20202S	1.8 m	70 mm	82 mm	25 mm	36 mm	31 mm
LVCT20403S	1.8 m					

1/3 V low-voltage CT form factor

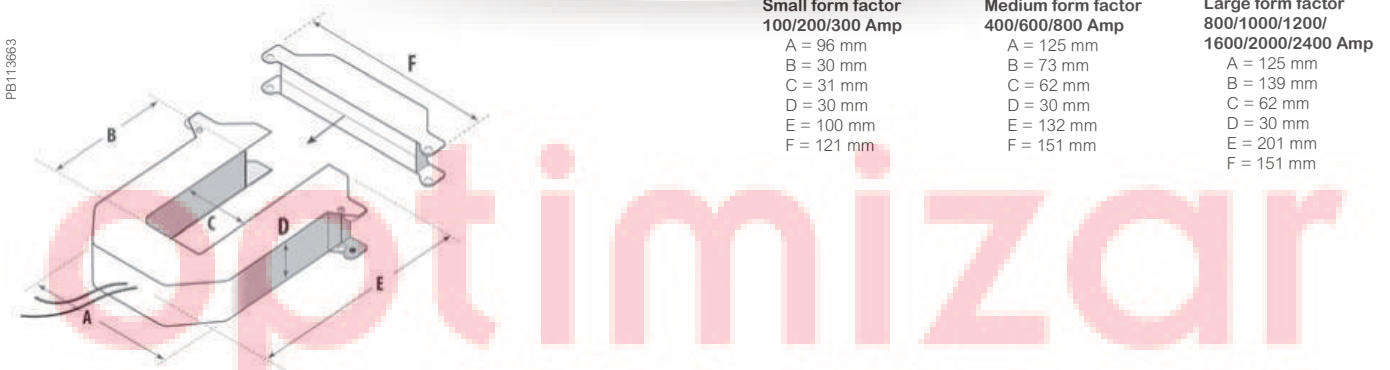

Small form factor
100/200/300 Amp
 A = 96 mm
 B = 30 mm
 C = 31 mm
 D = 30 mm
 E = 100 mm
 F = 121 mm

Medium form factor
400/600/800 Amp
 A = 125 mm
 B = 73 mm
 C = 62 mm
 D = 30 mm
 E = 132 mm
 F = 151 mm

Large form factor
800/1000/1200/1600/2000/2400 Amp
 A = 125 mm
 B = 139 mm
 C = 62 mm
 D = 30 mm
 E = 201 mm
 F = 151 mm

BCPM

PowerLogic BCPM with solid core CT strips installation details

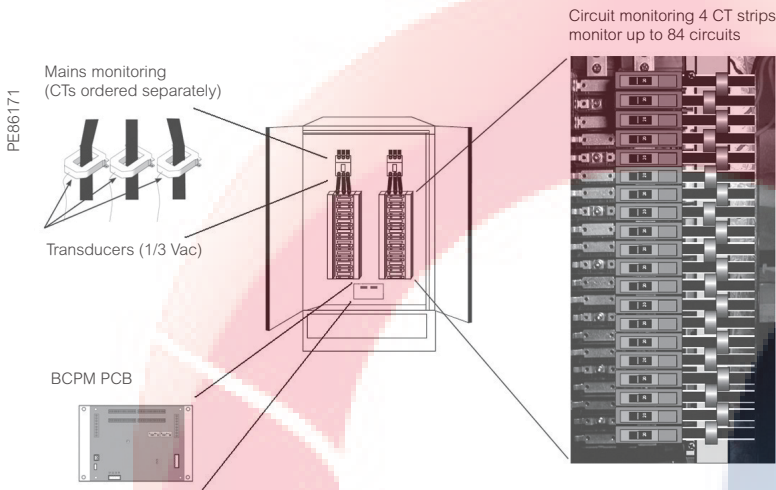

PowerLogic BCPM with split-core CTs installation details

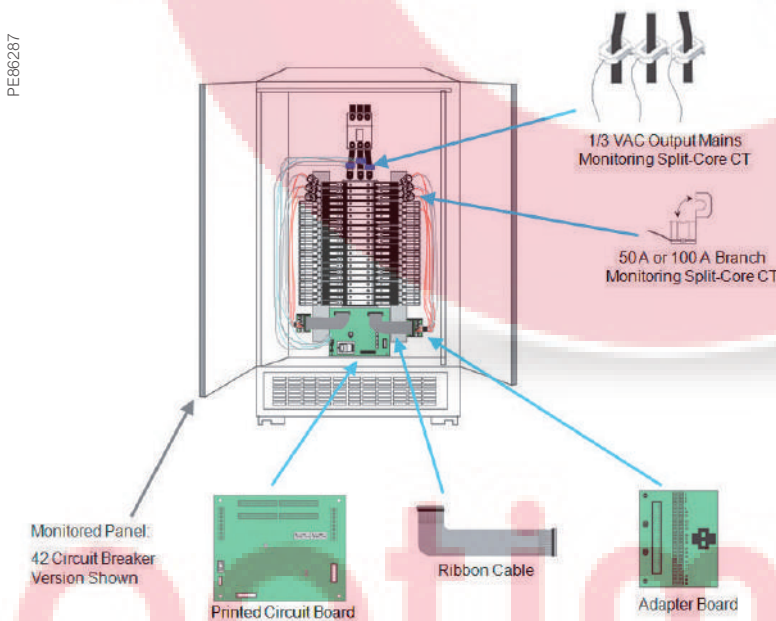

EM4000 series

The compact PowerLogic EM4000 series multi-circuit energy meter from Schneider Electric enables the reliable monitoring of building electrical loads with a low installation cost-per-point by combining revenue-accurate electricity sub-metering with advanced communications technology.

Applications

- Energy management
- Energy cost allocation
- Utility bill verification

PB113714



METSEEM403316

The solution for

Markets that can benefit from a solution that includes PowerLogic EM4000 series meters:

- Buildings
- Industry
- Healthcare
- Data Centre and networks
- Infrastructure

Benefits

System integrators' benefit

- Ease of integration
- Ease of setup
- Cost effectiveness

Panel builders' benefit

- Ease of installation
- Cost effectiveness
- Aesthetically pleasing
- Simplified ordering

End users' benefit

- Ease of use
- Precision metering & sub-billing
- Billing flexibility
- Comprehensive, consistent and superior performance

Competitive advantages

- Compact, maintenance-free design
- Hi-density, flexible connection
- Direct connection
- Multiple CT types
- No rewiring required
- Integrated communications networks.

Power management solutions

Schneider Electric provides innovative power management solutions to increase your energy efficiency and cost savings, maximise electrical network reliability and availability, and optimise electrical asset performance.

Conformity of standards

- IEC 61557-12
- IEC 61000-4-4
- IEC 62053-22
- IEC 61000-4-5
- IEC 62053-24
- IEC 61000-4-6
- IEC 61010-1
- IEC 61000-4-8
- IEC 61000-4-2
- Etc.
- IEC 61000-4-3

optimizer

EM4000 series



EM4000 series multi-circuit energy meter

The compact PowerLogic EM4000 series multi-circuit energy meter from Schneider Electric enables the reliable monitoring of building electrical loads with a low installation cost-per-point by combining revenue-accurate electricity sub-metering with advanced communications technology.

The EM4000 is ideal for departmental metering applications and M&V within office towers, condominiums, apartment buildings, shopping centres and other multi-user environments, or small-footprint retail.

The PowerLogic EM4000 series meters monitor up to 24 meter points with a single device. Multiple meters can be combined to support an unlimited number of points.

Two meter models offer a choice of CTs and installation options:

- PowerLogic EM4033: 333 mV, split-core CTs
- PowerLogic EM4080: 80 mA solid core CTs

Main characteristics

- Compact, maintenance-free design
 - Requires no floor space
- Hi-density, flexible connection
 - From single-pole to single- or three-phase metering, supports up to 24 circuits.
 - Select the connection type using an intuitive configuration tool.
- Direct connection
 - For 100 - 300 V AC L-N electrical distribution systems: 120/240 V, 120/208 V, 277/480 V
- Multiple CT types
 - Support a variety of needs in both new and retrofit installations.
 - 1/3 V output CT option does not require shorting blocks, making it the ideal choice for retrofit installations.
- No rewiring required
 - Use existing wiring to connect to existing panels.
- Integrated communications networks.
 - Onboard Ethernet or RS-485 allows for easy integration into existing communications networks.

Feature selection		
Commercial ref. no.	Model	Description
METSEEM403316	EM4033	PM5310 CI 0.5, RS-485 Modbus, 2DI/2DO
METSEEM403336		PM5330 CI 0.5, RS-485 Modbus, 2DI/2DO, Relay
METSEEM408016	EM4080	PM5331 Power & Energy meter
METSEEM408036		PM5320 Power & Energy meter

EM4000 series

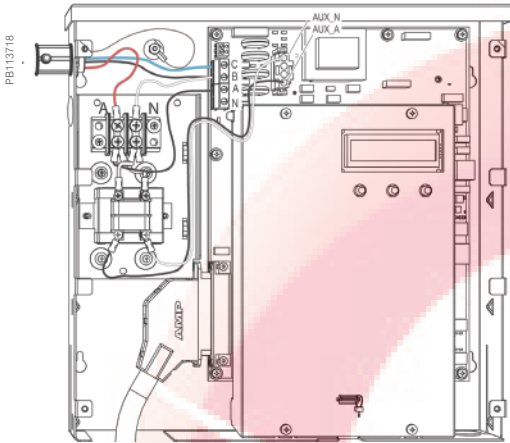

PowerLogic EM4000 meter 480Y/277V three-phase wye service connection

Selection guide		EM4033	EM4080
General			
Use on LV systems		■	■
Accuracy	+/- 0.5 %	■	■
Accuracy compliance	ANSI C12.1 and C12.20 Class 0.5; IEC 62053-22, Class 0.5S	■	■
Maximum circuits: single-pole / single-phase / three-phase	24 / 12 / 8	■	■
Instantaneous rms values			
Energy	real, kWh received/delivered	■	■
	reactive, kvarh received/delivered	■	■
	apparent, VAh	■	■
Voltage		■	■
Pulse counts		■	■
Voltage and current	V rms, I rms per phase	■	■
Power	real, reactive, apparent	■	■
Power factor		■	■
Measurements available for data logging			
Energy	real, kWh received/delivered	■	■
	reactive, kvarh received/delivered	■	■
	apparent, VAh	■	■
Voltage		■	■
Display			
Backlit LCD display	2 lines of 16 characters	■	■
Optional remote modular display available		■	■
Communication			
Ethernet port		■	■
MODBUS-RTU over RS-485		■	■
Pulse inputs	2	■	■
Protocols: Modbus TCP/IP, HTTP, BACnet/IP, FTP, and SNMP		■	■
Installation options			
0.333 V CTs		■	
80 mA CTs			■
Split-core CT		■	
Solid core CT		■	■

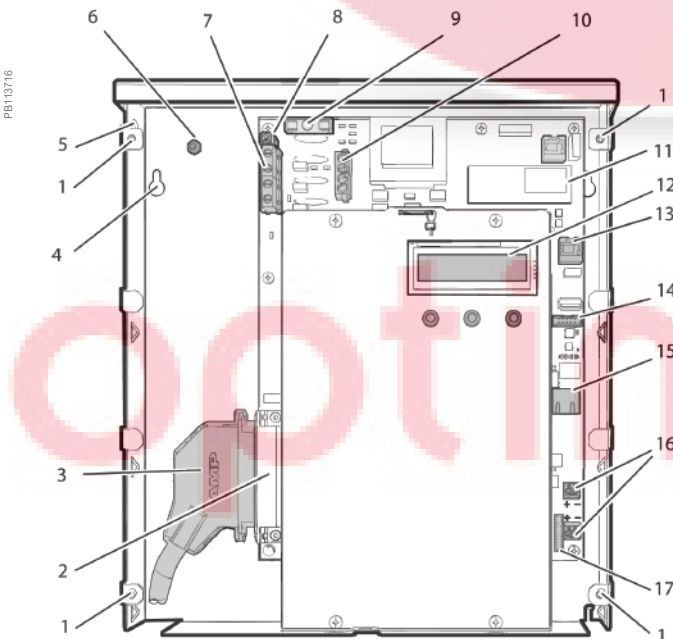

- Legend:
- 1 Cover screw location
 - 2 Meter point input connector
 - 3 Cable connector
 - 4 Mounting keyhole
 - 5 Ingress punch-outs
 - 6 Earth stud
 - 6 Sense voltage terminal block
 - 8 Control voltage terminal block
 - 9 Fuse
 - 10 Control voltage jumper
 - 11 RTU interface
 - 12 Display
 - 13 Remote display connector
 - 14 Serial RS-232
 - 15 Ethernet port
 - 16 Pulse in terminal blocks
 - 17 Pulse out connector

EM4000 series

EM4000 technical specifications

Electrical characteristics		
Input-voltage characteristics	Inputs	V1, V2, V3, Vn
	Measured voltage	80 - 480 V AC L-L without PTs Up to 999 kV with external PTs
	Frequency range	60 Hz
Mechanical characteristics		
Weight	EM4033/EM4080	approx. 4.0 kg
Dimensions	EM4033/EM4080	335 x 305 x 55 mm
Environmental conditions		
Operating temperature		-40 °C to 70 °C
Storage temperature		-40 °C to 70 °C
Humidity rating		0 % to 90 % RH non-condensing
Enclosure		Type 1 (indoor or enclosed outdoor use)
Altitude		3000 m
Pollution degree		2
Safety and standards		
UL Certified to IEC/EA/CSA 61010-1		
CSA-C22.2 No 61010-1-04		
FCC Part 15 Class B		
ICES-003 EN 55022, IEC 6100-4-5		
ANSI/TIA968-A: 2002		
Communication		
Ports		Ethernet
		MODBUS-RTU over RS-485
Pulse inputs		2
Protocols: Modbus TCP/IP, HTTP, BACnet/IP, FTP, and SNMP		
Display characteristics		
Integrated backlit LCD display		2 lines, 16 digits per line display; R / L arrow buttons select metering point; Display button cycles through measurements per point.

optimizer

EM4X00, CT termination, PT module

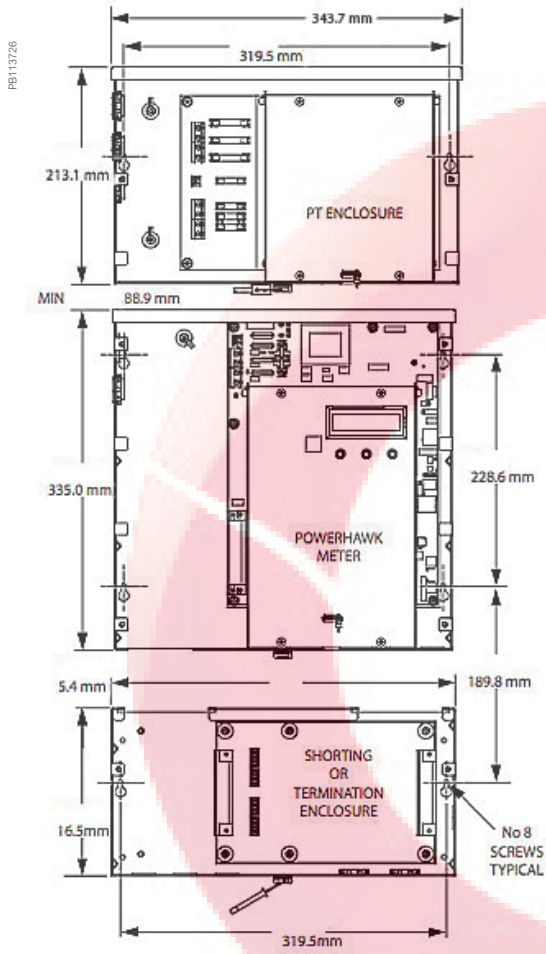

EM4X00, CT termination, PT module

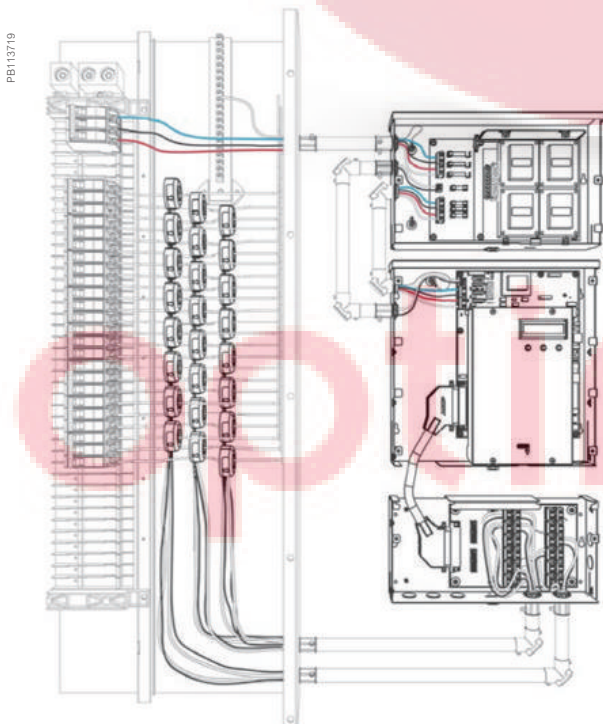

EM4000 series

PB113724



METSEPTMOD480

PT Module

The PT module provides step-down voltage connections to Schneider Electric PowerLogic meters for metering single-phase to three-phase voltages of 600 V, 347 V, or 400 V, while meeting all regulatory electrical safety and ANSI 0.5 Accuracy Class standards. The PT module provides both the per-phase input metering voltages and the auxiliary input power required by Schneider Electric PowerLogic energy meters.

There are two variants of the PT module that support the following source voltages and wiring configurations:

- 347 V Wye / 600 V Delta variant supports:
 - 347 V, three-phase, 4-wire wye
 - 600 V, three-phase, 3-wire delta
- 480V Delta variant supports:
 - 480 V, three-phase, 3-wire delta

The 347 V/600 V PT module variant has three sense voltage potential transformers for metering. The configuration of the transformers (347 V wye or 600 V delta) is selected by using the jumper provided. The 480V PT module has two sense voltage potential transformers for metering. There is a separate auxiliary power transformer in both variants to operate the meter. All voltage inputs are fused.

PowerHawk PT module specifications			
Dimensions	Height	213.1 mm	
	Width	54 mm	
	Depth	54 mm	
	Weight	5.67 kg	
Fuse ratings	High voltage inputs	F1	T315 mA, 1000 V
		F2	T315 mA, 1000 V
		F3	T315 mA, 1000 V
	Voltage inputs	F4	T250 mA, 250 V
		F5	T250 mA, 250 V
		F6	T250 mA, 250 V
		F7	T250 mA, 250 V
Transformer specifications	Input voltage	600 V	Voltage tolerance: +/-10 %
		480 V	Voltage tolerance: +/-10 %
		347 V	Voltage tolerance: +/-10 %
	Output voltage	120 V	Accuracy: 0.3 %
	Environmental	Operating temperature	-40 °C to 70 °C
Operating humidity		5 % to 90 % non-condensing	
Usage environment		Indoor or enclosed outdoor environment	
Maximum altitude		3000 m	
Pollution degree		2	

optimizer

Feature selection	
Commercial ref. no.	Description
METSEPTMOD480	480 V PT Module for EM4X00 meter
METSEPTMOD347600	347 V/600 V PT Module for EM4X00 meter

EM4000 series

PB113725

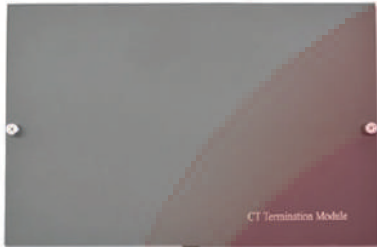

CT Module

PowerLogic 4080 meters have two shorting options that provide a seamless and sealable mechanical package. The CT Shorting Module provides CT connections via the color coded 25 pair cable routed into the breaker panel. All CTs are shorted at the same time for safe removal of the meter for maintenance when the electrical circuits are still live.

The CT Termination Module has the same shorting ability, but provides CT connections via 24 2-position screw-down terminal blocks. Individual pairs are then routed from the CT Termination Module to 1 or more breaker panels via conduit knock outs provided on the module. Thus eliminating the need for a splitter box to route CT cables to multiple panels.

Commercial ref. no.	Description
METSECTTERM	CT Termination Module for EM4X00 meter
METSECTSHORT	CT Shorting Module for EM4X00 meter

PB113729

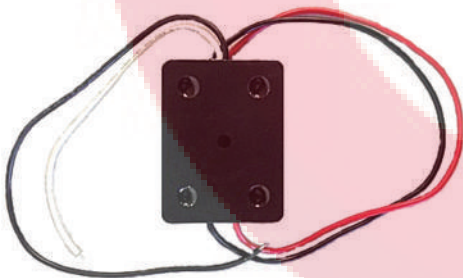

Converter

The 5 A:80 mA converter is useful in applications where there are existing 5 A CT's integrated into large motors or switch gear. The 5 A:80 mA converter matches the 5 A secondary of the load to the 80 mA input of the meter. In Billing Grade applications, the 5 A:80 mA converter is also used to connect regulatory grade large aperture, large amperage CT's with 5 A secondaries to the 80 mA of PowerLogic 4 X 80 meters.

Commercial ref. no.	Description
METSECONV580	5 A : 80 mA converter for EM4X00 meter



METSECONV580

PB111056

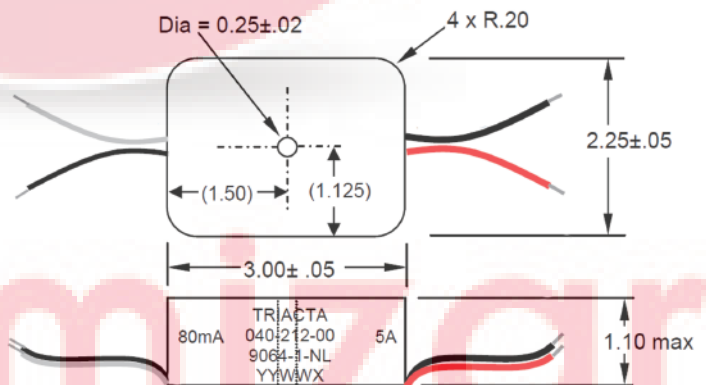

The 5 A to 80 mA converter dimensions

See appropriate Installation Guide for this product.

EM4000 series

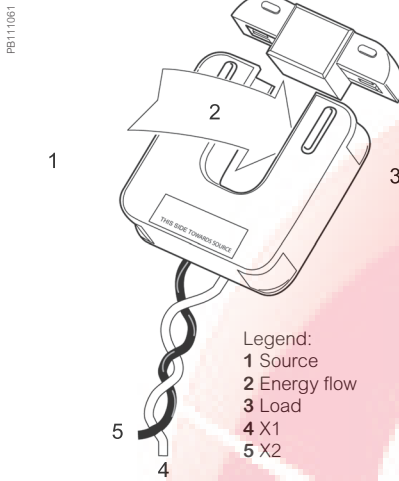

CTs

- Model 8 (80/100 mA Secondary)
- Window Size: 82.5 mm Diameters
- Application: Metering
- Frequency: 50-400 Hz
- Insulation Level: 600 Volts, 10 Kv BIL Full Wave
- Flexible leads available for all case configurations. Flexible leads are UL 1015 105 °C, CSA approved #16 AWG, 609.6 mm long standard length. Non-standard lengths are available upon request.
- Terminals are brass studs No. 8-32 UNC with one flat washer, one lock washer and one nut each. Terminals are only available on the square case configuration.
- Mounting brackets kits for the Model 8SHT are available when required.
- Approximate weight: 1.36 kg

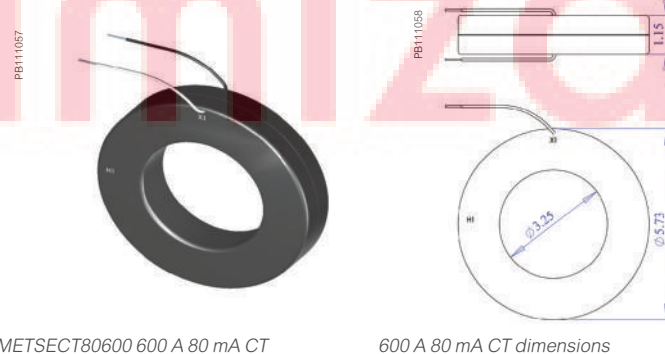
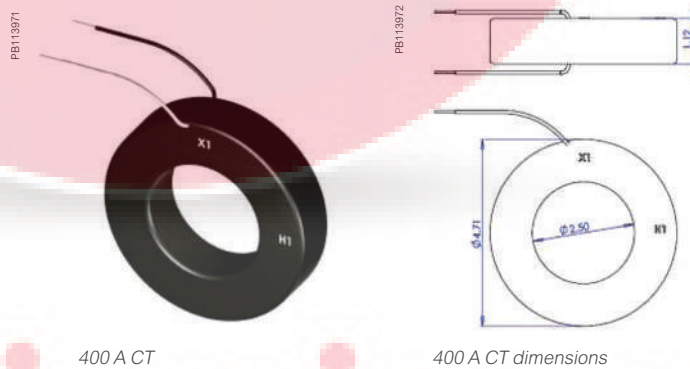
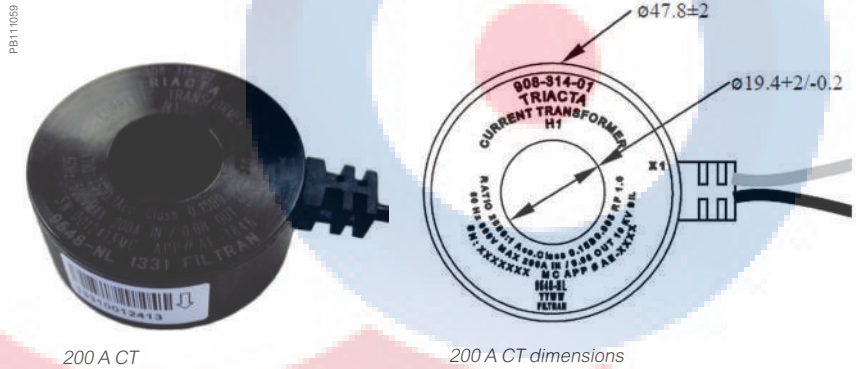

Feature selections	
Commercial reference number	Description
METSECT80200	CT, solid core, 200 A primary, 80 mA secondary, for use with EM4X80 multi-circuit meter
METSECT80400	CT, solid core, 400 A primary, 80 mA secondary, for use with EM4X80 multi-circuit meter
METSECT80600	CT, solid core, 600 A primary, 80 mA secondary, for use with EM4X80 multi-circuit meter

EM4800 series

The compact PowerLogic EM4800 series multi-circuit energy meter from Schneider Electric enables reliable metering of individual tenants with a low installation cost-per-point by combining revenue-accurate electricity sub-metering with advanced communications technology. The ideal fit for high-end cost management applications, providing the measurement capabilities needed to allocate energy usage, perform tenant metering and sub-billing, pin-point energy savings, optimise equipment efficiency and utilisation, and perform a high level assessment of the power quality in an electrical network.

Applications

Capable of essential cost management:

- Multi-tenant metering
- Energy management
- Energy cost allocation
- Utility bill verification

PE66325

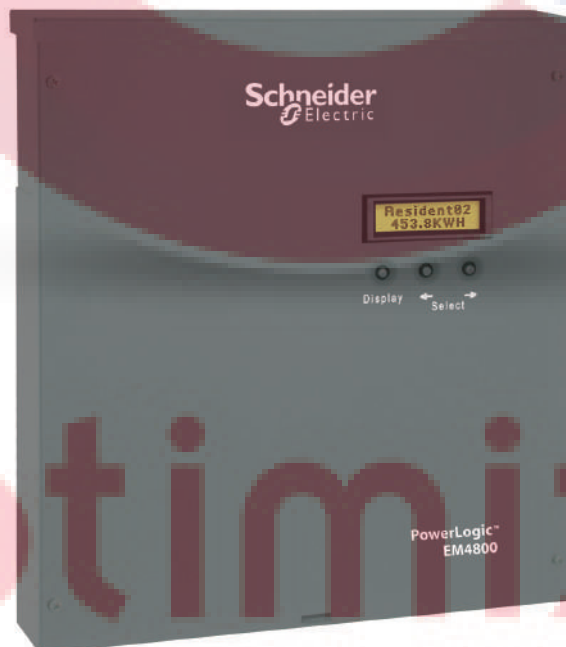

METSEEM480525

The solution for

Markets that can benefit from a solution that includes PowerLogic EM4800 series meters:

- Buildings
- Industry
- Healthcare
- Data Centre and networks
- Infrastructure

Benefits

System integrators' benefit

- Ease of integration
- Ease of setup
- Cost effectiveness

Panel builders' benefit

- Ease of installation
- Cost effectiveness
- Aesthetically pleasing
- Simplified ordering

End users' benefit

- Ease of use
- Precision metering & sub-billing
- Billing flexibility
- Comprehensive, consistent and superior performance

Competitive advantages

- Compact, maintenance-free design
- Hi-density, flexible connection
- Direct connection
- Multiple CT types
- No rewiring required
- Integrated communications

Power management solutions

Schneider Electric provides innovative power management solutions to increase your energy efficiency and cost savings, maximise electrical network reliability and availability, and optimise electrical asset performance.

Conformity of standards

- IEC61557-12
- IEC62053-22
- IEC62053-24
- IEC 61010-1
- IEC 61000-4-2
- IEC 61000-4-3
- IEC 61000-4-4
- IEC 61000-4-5
- IEC 61000-4-6
- IEC 61000-4-8
- Etc.

optimizer

EM4800 series

PE86325

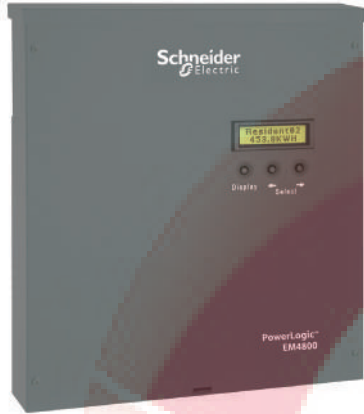

EM4800 series multi-circuit energy meter front (above), installed in panel (below)

PE86326



The compact PowerLogic EM4800 series multi-circuit energy meter from Schneider Electric enables reliable metering of individual tenants with a low installation cost-per-point by combining revenue-accurate electricity sub-metering with advanced communications technology.

The EM4800 is ideal for multi-tenant or departmental metering applications within office towers, condominiums, apartment buildings, shopping centres and other multi-user environments.

The PowerLogic EM4800 series meters monitor up to 24 tenants with a single device. Multiple meters can be combined to support an unlimited number of suites.

- Three meter models offer a choice of CT secondary ratings and installation options:
 - PowerLogic EM4805: 5 A, split or solid core CTs
 - PowerLogic EM4833: 0.333 V, split or solid core CTs
 - PowerLogic EM4880: 80 mA, solid core CTs
- Main characteristics
 - Compact, maintenance-free design
 - Requires no floor space.
- Hi-density, flexible connection
 - From single-pole to single- or three-phase metering, supports up to 24 circuits. Select the connection type using an intuitive configuration tool.
- Direct connection
 - For 100 - 300 V AC L-N electrical distribution systems:
 - 120/240 V, 120/208 V, 230/240 V, 220/380 V, 240/415 V, 277/480 V
- Multiple CT types
 - Support a variety of needs in both new and retrofit installations.
 - 1/3 V output CT option does not require shorting blocks, making it the ideal choice for retrofit installations.
- No rewiring required
 - Use existing wiring to connect to existing panels.
- Integrated communications
 - Onboard Ethernet and modem allows for easy integration into existing communications networks.

Feature selections

Commercial ref. no.	Model	Description
METSEEM480525	EM4805	24 x 5 A inputs, 230/240 V control power, 50 Hz
METSEEM480516		24 x 5 A inputs, 120 V control power, 60 Hz
METSEEM483325	EM4833	24 x 333 mV inputs, 230/240 V control power, 50 Hz
METSEEM483316		24 x 333 mV inputs, 120 V control power, 60 Hz
METSEEM488016	EM4880	24 x 80 mA inputs, 120 V control power, 60 Hz
METSEEM488025		24 x 80 mA inputs, 230/240 V control power, 50 Hz

EM4800 series

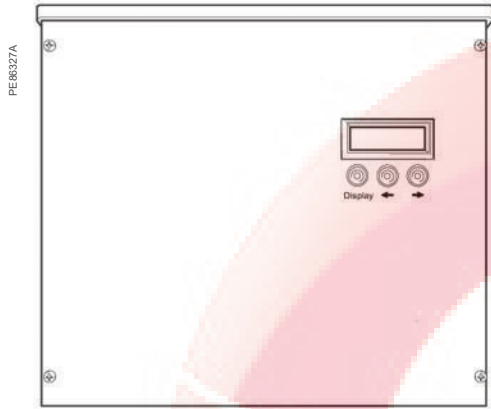

PowerLogic EM4800 series digital panel meter.

Selection guide		EM4805	EM4833	EM4880
General				
Use on LV systems		■	■	■
Accuracy	+/- 0.5 %	■	■	■
Accuracy compliance	ANSI C12.1 and C12.20 Class 0.5; IEC 62053-22, Class 0.5S	■	■	■
Maximum circuits: single-pole / single phase / three-phase	24 / 12 / 8	■	■	■
Instantaneous rms values				
Energy	Real, kWh received/delivered	■	■	■
	Reactive, kvarh received/delivered	■	■	■
	Apparent, VAh	■	■	■
Voltage		■	■	■
Pulse counts		■	■	■
Voltage and current	V rms, I rms per phase	■	■	■
Power	Real, reactive, apparent	■	■	■
Power factor		■	■	■
Measurements available for data logging				
Energy	Real, kWh received/delivered	■	■	■
	Reactive, kvarh received/delivered	■	■	■
	Apparent, VAh	■	■	■
Voltage		■	■	■
Display				
Backlit LCD display	2 lines of 16 characters	■	■	■
Optional remote modular display available		■	■	■
Communication				
Ethernet port		■	■	■
V.90 modem port		■	■	■
Pulse inputs	2	■	■	■
Protocols: Modbus TCP/IP, HTTP, BACnet/IP, FTP, and SNMP		■	■	■
Installation options				
5 A CTs		■		
0.333 V CTs			■	
80 mA CTs				■
Split-core CT		■	■	
Solid core CT		■	■	■
Remote modular display		■	■	■

optimizer

EM4800 series

Electrical characteristics		
Input-voltage characteristics	Inputs	V1, V2, V3, Vn
	Measured voltage	80 - 480 V AC L-L without PTs Up to 999 kV with external PTs
	Frequency range	50/60 Hz
Mechanical characteristics		
Weight	EM4805	approx. 5.4 kg
	EM4833/EM4880	approx. 4.0 kg
Dimensions	EM4805	335 x 44 x 55 mm
	EM4833 / EM4880	335 x 305 x 55 mm
Environmental conditions		
Operating temperature	-40 °C to 70 °C	
Storage temperature	-40 °C to 70 °C	
Humidity rating	0 % to 90 % RH non-condensing	
Enclosure	Type 1 (indoor or enclosed outdoor use)	
Altitude	3000 m	
Pollution degree	2	
Safety and standards		
UL Certified to IEC/EA/CSA 61010-1		
CSA-C22.2 No 61010-1-04		
FCC Part 15 Class B		
ICES-003 EN55022, IEC 6100-4-5		
ANSI/TIA968-A: 2002		
Communication		
Ports	Ethernet	
	V.90 modem	
Pulse inputs	2	
Protocols: Modbus TCP/IP, HTTP, BACnet/IP, FTP, and SNMP		
Display characteristics		
Integrated backlit LCD display	2 ines, 16 digits per line display; R / L arrow buttons select metering point; Display button cycles through measurements per point.	

optimizer

EM4900 series

The PowerLogic EM4900 Series Multi-Circuit Meters make it easy to add many metering points without having to purchase, mount, wire and commission individual energy meters. Simply add a single device with common voltage inputs and communication interface that can measure the current, voltage, power, energy consumption, and Total harmonic Distortion (THD) of up to (14) 3-phase circuits with a single board or up to (28) 3-phase circuits with a two board configuration. Save on both equipment cost and installation.

Applications

- Commercial and residential subtenant billing
- Load-based cost allocation
- Measuring for load balancing and demand response
- Overload protection

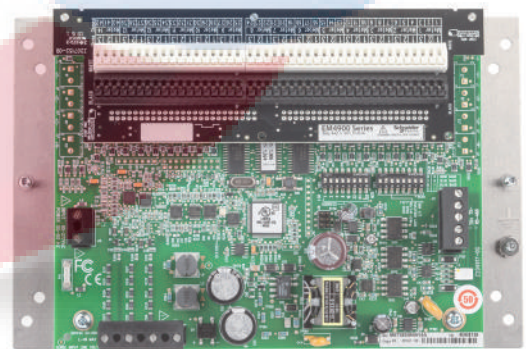

PB117150

PB117149

optimizer



METSEEM4904E



METSEEM4904A

The solution for

Markets that can benefit from a solution that includes PowerLogic EM4900 series meters:

- Buildings
- Industry
- Healthcare
- Hotels, Multi-Dweller Units (condos)

Benefits

System integrators' benefit

- Ease of integration
- Ease of setup
- Cost effectiveness

Panel builders' benefit

- Ease of installation
- Cost effectiveness
- Aesthetically pleasing
- Simplified ordering

End users' benefit

- Ease of use
- Precision metering & sub-billing
- Billing flexibility
- Comprehensive, consistent and superior performance

Competitive advantages

- Lower cost and space per metering point
- Adapts to any mix of metering needs (1ph, 2ph, 3ph with or without Neutral wire)
- Class 0.5 accuracy for Revenue Grade measurement
- THD monitoring to help identify problem loads and early wear and tear
- Capable of concurrent communication to software packages, including PowerLogic software packages and third party systems

Power management solutions

Schneider Electric provides innovative power management solutions to increase your energy efficiency and cost savings, maximise electrical network reliability and availability, and optimise electrical asset performance.

Conformity of standards

- EN 61000-6-3 Class B - Part 6-3
- EN 61000-6-3 Class B - Part 6-3
- EN 61000-6-4 Class A - Part 6
- EN 61010-1 - Part 1
- EN 61326-1 Class A - Part 1
- EN 61326-1 Class B - Part 1
- IEC 62053-22 Class 0.5 - Part 21
- FCC 47 CFR Part 15 Class A & Class B
- UL 508 Open Device Type
- IEC 61010-1 - Part 1

optimizer

EM4900 series

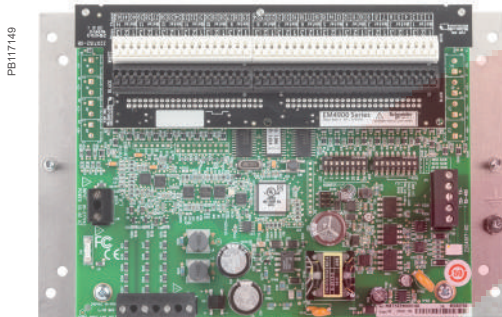

PB117149

PowerLogic™ EM4914A

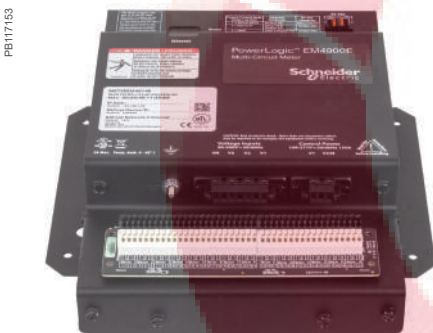

PB117153

PowerLogic™ EM4914E

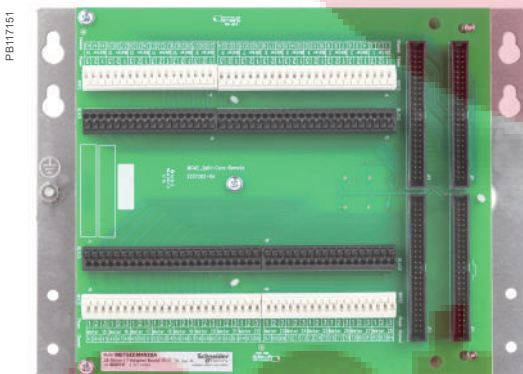

PB117151

28 Meter adapter board (EM4928A and EM4928E)

To aid in commissioning, a configuration software tool, an Ethernet discovery tool (for the EM49xxE) and a User Guide are available online at www.schneider-electric.com.

- Main characteristics

- Add lots of metering points without lots of cost
 - Add up to 28 3-phase meters by installing a single product small enough to fit inside many distribution panels. Save on both equipment cost and installation cost. Common voltage and communication connections and color-coded push-in CT connections save installation time and effort.
- Class 0.5 accuracy for Revenue Grade measurements
 - Power and Energy measurements with ANSI and IEC class 0.5 accuracy provide the accuracy needed for tenant billing applications. Voltage and current measurement accuracy is 0.5 % and currents are measured down to 0.1% of the CT range. Easily differentiate between the flow of low current and a trip or load disconnect where no current flows.
- Total Harmonics Distortion measurements
 - Helps assess basic power quality to reduce risks to the load and provide indication of potential early wear and tear of the electrical network and its load.
- Common CTs, 1/3V outputs
 - CTs with low-voltage outputs eliminate the need for shorting blocks that add cost and labor to the installation. They also allow long CT lead extensions without compromising accuracy. Choose from a range of our CT styles and sizes or use any CTs with industry-standard 0.333V outputs.
- Models with integrated Ethernet offer broad protocol support
 - All models integrate easily into existing networks using Modbus RTU communications over an RS-485 serial link. EM49xxE models offer integrated Ethernet and add support for Modbus TCP, BACnet IP, BACnet MS/TP and SNMP. Those Ethernet protocols can be run in parallel allowing multiple software to access the device (Building Management System, Energy Management System, etc.) An optional external gateway can be added to EM49xxA models to offer the same capability.
- Compatible with PowerLogic power monitoring software
 - Easily turn the large amount of data collected by the devices into useful decision making information.
- Configure the meters you want
 - Choose 4, 8, 14 or 28 3-phase meters. User-configurable to any combination of 1-, 2-, 3-phase meters. Reconfigure channels as needed to monitor neutral current.

EM4900 series specifications

Measurements	
Measurement voltage	90 to 300 V AC L-N, 50/60 Hz
Total Harmonic Distortion (THD)	THD % voltage L-L, L-N and THD % on current
Control power	
EM49xxA	90 to 277 V AC L-N, 50/60 Hz
EM49xxE	100 to 277 V AC L-N, 50/60 Hz
Accuracy	
Power/Energy	IEC 62053-21 Class 0.5, ANSI C12.20 class 0.5
Voltage	±0.5% of reading 90 to 277 V L-N
Current	±0.5% of reading from 2% to 100% of full-scale
Operation	
Sampling frequency	2560 Hz
Update rate	1.8 seconds (both panels)
Overload capability	22 kAIC
EM49xxA serial communication	
Type	Modbus RTU
Connection	DIP switch-selectable 2-wire or 4-wire, RS-485
Address	DIP switch-selectable address 1 to 247 (in pairs of 2) (See Installation Guide)
Baud rate	DIP switch-selectable 9600, 19200, 38400
Parity	DIP switch-selectable NONE, ODD, EVEN
Communication format	8 data bits, 1 start bit, 1 stop bit
Termination	5-position plug-in connector (TX+ TX- SHIELD TX+/RX+ TX-/RX-)
EM49xxE serial communication	
Physical Interface	2-wire RS-485
Serial protocols supported	Modbus RTU or BACnet MS/TP
Address range	1 to 247 for Modbus RTU; 0 to 127 for BACnet MS/TP
Baud rate	9600, 19200, 38400
Parity	Modbus RTU: NONE, ODD, EVEN BACnet MS/TP: NONE (fixed)
Communication format	8 data bits, 1 start bit, 1 stop bit
Termination	2x3 position connector
EM49xxE Ethernet communication	
Physical interface	Protocols Supported
Protocols supported	Modbus TCP, BACnet IP, SNMP V2c
Wire size range	
Removable connectors on main board	24 to 12 AWG
CT Terminals and EM49xxE serial connector terminals	26 to 16 AWG
Terminal block torque	
Removable connectors	0.5 to 0.6 N-m
Mechanical	
Ribbon cable support (28-meter models only)	0.9 m round ribbon cable ships standard; up to 6 m flat or round available
Operating conditions	
Operating temperature range	0 to 60 °C (<95% RH non-condensing)
Storage temperature range	-40 to 70 °C
Altitude of operation	3000 m
Mounting location	Not suitable for wet locations. For indoor use only.
Compliance information	
Agency approvals	UL 508 open type device ^{*1} , IEC/EN 61010-1
Installation category	Cat III, pollution degree 2 ^{*2}
Conducted emissions	EM49xxA Models: FCC part 15 Class B, EN 61000-6-3, EN 61326-1 Class B (residential & light
Radiated emissions	EM49xxE Models: FCC part 15 Class A, EN 6100-6-4, EN 61326-1 Class A
Conducted and radiated immunity	EN 61000-6-2 and EN 61326-1

*1 Install EM49xx in appropriate fire enclosure; if used with circuits higher than product ratings, circuits must be segregated per UL 508A Sec 17.5 (EM49xx internal circuitry are not circuits as defined by UL 508A).

*2 A Pollution Degree 2 environment must control conductive pollution and the possibility of condensation or high humidity. Consideration must be given to the enclosure, the correct use of ventilation, thermal properties of the equipment and the relationship with the environment.

EM4900 series

1/3 V low-voltage CT (LVCT)	
Electrical characteristics	
Accuracy	1 % from 10 % to 100 % of rated current(LVCT0xxx0S/1S/2S/3S/4S [split-core]) 0.5 % from 5 % to 100 % of rated current (LVCT2xxx0S/2S/3S [solid core])
Frequency range	50/60 Hz
Leads	18 AWG, 600 V AC, 1.8 m standard length
Max. voltage L-N sensed conductor	300 V AC (LVCT0xxx0S) 600 V AC (LVCT0xxx1S/2S/3S/4S, LVCT2xxxxS)
Measurements	
Real time measurements	Current: multi-phase average and per phase Current phase angle per branch Real power (kW): multi-phase total and per phase Apparent power (kVA): multi-phase total and per phase Power factor: multi-phase average and per phase
Demand measurements	Current present demand: multi-phase average and per phase Real power (kW) present demand: multi-phase average and per phase
Historic maximums	Maximum instantaneous current: multi-phase average and per phase Maximum current demand: multi-phase average and per phase Maximum real power demand: multi-phase total and per phase
Accumulate energy	Energy (kWh): multi-phase total and per phase
Energy snapshots	Energy (kWh): multi-phase total and per phase

optimizer

EM4900 series

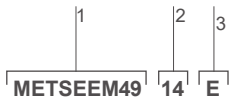

- 1 Model.
- 2 Number of 3-phase meters (without neutral current)
- 3 Communication interfaces & protocols.

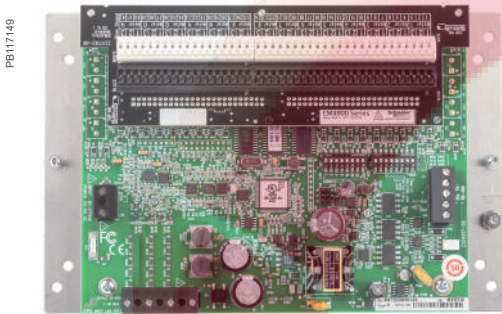

EM49xxA Main Board



EM49xxE Main Unit

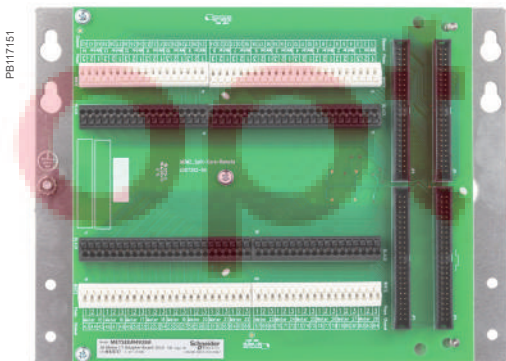

CT Adapter Assembly (28-Meter models only)

EM4900 series part numbers - BCPM with solid core CTs

Item	Code	Description
1 Model	METSEEM49	Multi-Circuit Meter
2 Number of 3-phase Meters	04	Up to (4) 3-phase Meters (see table for variations)
	08	Up to (8) 3-phase Meters (see table for variations)
	14	Up to (14) 3-phase Meters (see table for variations)
	28	Up to (28) 3-phase Meters (see table for variations)
3 Communication Interfaces & Protocols	A	RS-485 Serial with Modbus RTU (add E8951 for other protocols)
	E	Ethernet with Modbus TCP, BACnet IP and SNMP protocols and RS-485 Serial with Modbus RTU or BACnet IP

Commercial ref. no.	"E" - Integrated Ethernet	Number of meters		
		3-phase	2-phase	1-phase
METSEEM4904A	METSEEM4904E	4	6	12
METSEEM4908A	METSEEM4908E	8	12	24
METSEEM4914A	METSEEM4914E	14	21	42
METSEEM4928A	METSEEM4928E	28	42	84

Number of meters supported:

EM4900 models are all factory-configured as all 3-phase meters (w/o neutral). They can be easily re-configured to any combination of 1-ph, 2-ph or 3-ph meters (with ION Setup). Any unused channels can be used to measure neutral current. Label overlays (to re-number CT connections) are provided for 1-ph/2-ph applications.

Commercial ref. no.	EM4900 multi-circuit meters
METSEEM4904A	Multi-Circuit Meter – (4) 3-phase meters - Modbus RTU only
METSEEM4908A	Multi-Circuit Meter – (8) 3-phase meters - Modbus RTU only
METSEEM4914A	Multi-Circuit Meter – (14) 3-phase meters - Modbus RTU only
METSEEM4928A	Multi-Circuit Meter – (28) 3-phase meters - Modbus RTU only
METSEEM4904E	Multi-Circuit Meter – (4) 3-phase meters - Ethernet and Serial (Modbus, BACnet & SNMP)
METSEEM4908E	Multi-Circuit Meter – (8) 3-phase meters - Ethernet and Serial (Modbus, BACnet & SNMP)
METSEEM4914E	Multi-Circuit Meter – (14) 3-phase meters - Ethernet and Serial (Modbus, BACnet & SNMP)
METSEEM4928E	Multi-Circuit Meter – (28) 3-phase meters - Ethernet and Serial (Modbus, BACnet & SNMP)



EM4900 series

PE66284

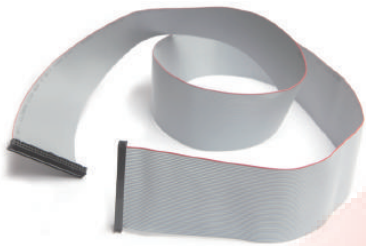

CBL008

Flat ribbon cable

PB117152



CBL022

Round ribbon cable

PE66183



LVCT00050S

PowerLogic™ LVCT0xxxxS split-core Low-voltage (1/3V) CTs are ideal for retrofit applications

PB113652



PB113657



PB113656



LVCT20050S

PowerLogic™ LVCT2xxxxS Low-voltage (1/3V) solid core CTs are ideal for panel builders (small, medium, large)

EM4900 series accessories

Commercial reference number	Description
BCPMCOVERS	EM4900 circuit board cover
E8951	Modbus to BACnet protocol converter
Ribbon cables for 28-meter models	
1.22 m cables are standard – others must be ordered separately	
CBL008	Flat Ribbon cable (quantity 1) for BCPM, length = 0.45 m
CBL016	Flat Ribbon cable (quantity 1) for BCPM, length = 1.2 m
CBL017	Flat Ribbon cable (quantity 1) for BCPM, length = 1.5 m
CBL018	Flat Ribbon cable (quantity 1) for BCPM, length = 1.8 m
CBL019	Flat Ribbon cable (quantity 1) for BCPM, length = 2.4 m
CBL020	Flat Ribbon cable (quantity 1) for BCPM, length = 3.0 m
CBL021	Flat Ribbon cable (quantity 1) for BCPM, length = 6.1 m
CBL022	Round Ribbon cable (quantity 1) for BCPM, length = 1.2 m
CBL023	Round Ribbon cable (quantity 1) for BCPM, length = 3 m
CBL024	Round Ribbon cable (quantity 1) for BCPM, length = 6.1 m
CBL031	Round Ribbon cable (quantity 1) for BCPM, length = 0.5 m
CBL033	Round Ribbon cable (quantity 1) for BCPM, length = 0.8 m

1/3 V low-voltage Split-core CTs

Commercial reference number	Amperage rating	Inside dimensions
LVCT00050S	50 A	10 x 11 mm
LVCT00101S	100 A	16 x 20 mm
LVCT00201S	200 A	32 x 32 mm
LVCT00102S	100 A	30 x 31 mm
LVCT00202S	200 A	30 x 31 mm
LVCT00302S	300 A	30 x 31 mm
LVCT00403S	400 A	62 x 73 mm
LVCT00603S	600 A	62 x 73 mm
LVCT00803S	800 A	62 x 73 mm
LVCT00804S	800 A	62 x 139 mm
LVCT01004S	1000 A	62 x 139 mm
LVCT01204S	1200 A	62 x 139 mm
LVCT01604S	1600 A	62 x 139 mm
LVCT02004S	2000 A	62 x 139 mm
LVCT02404S	2400 A	62 x 139 mm

1/3 V low-voltage Solid core CTs

Commercial reference number	Amperage rating	Inside dimensions
LVCT20050S	50 A	10 mm
LVCT20100S	100 A	10 mm
LVCT20202S	200 A	25 mm
LVCT20403S	400 A	31 mm

EM4900 series

EM49xxA main board dimensions

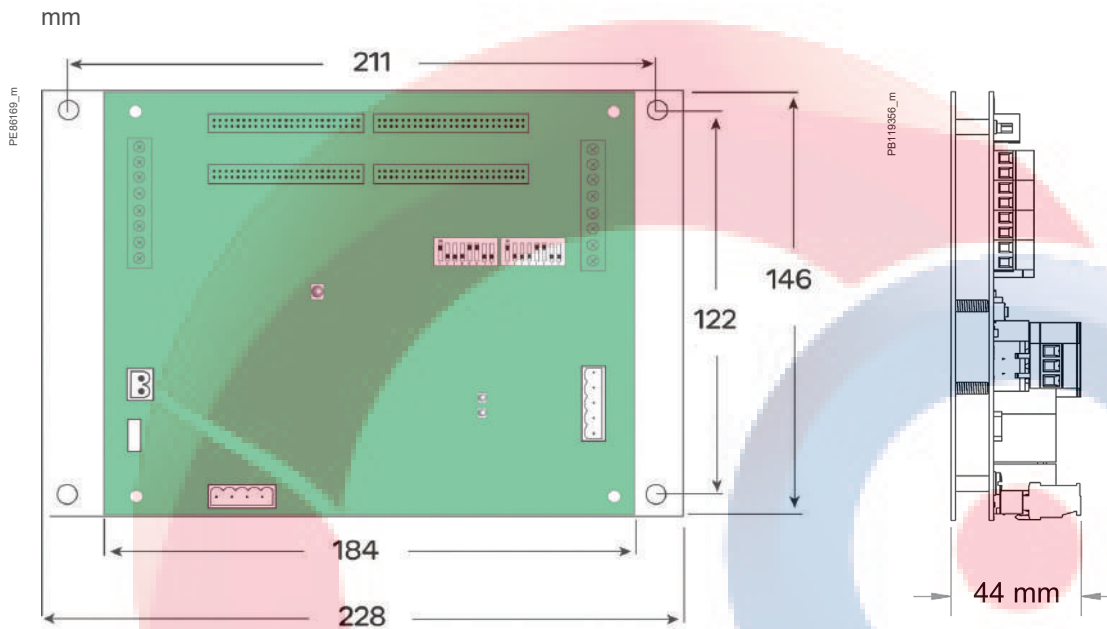

28-Meter CT adapter assembly dimensions

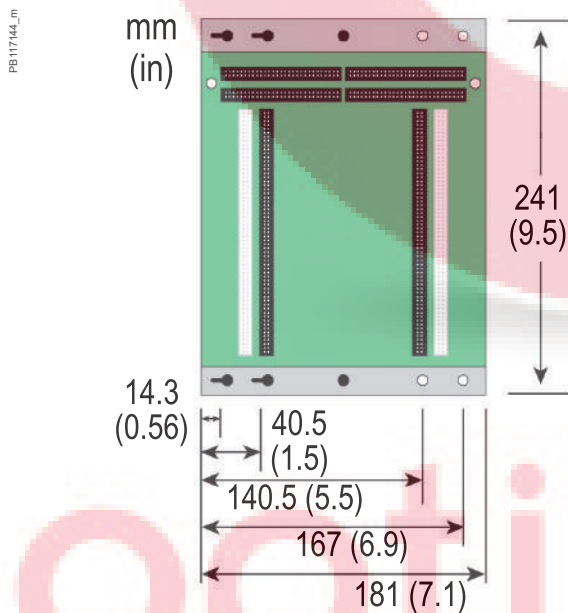

EM4900 series

50 A-200 A Split-core CT dimensions

PB113659

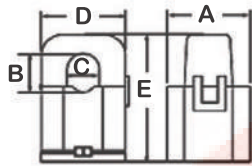

CT rating	A	B	C	D	E
50 A	26 mm	11 mm	10 mm	23 mm	40 mm
100 A	28 mm	16 mm	16 mm	40 mm	52 mm
200 A	37 mm	32 mm	32 mm	62 mm	69 mm

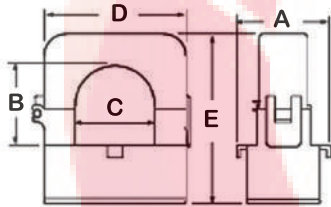
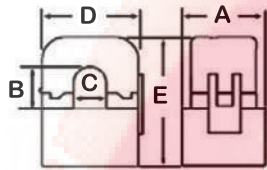

Solid core CT dimensions

PB113660

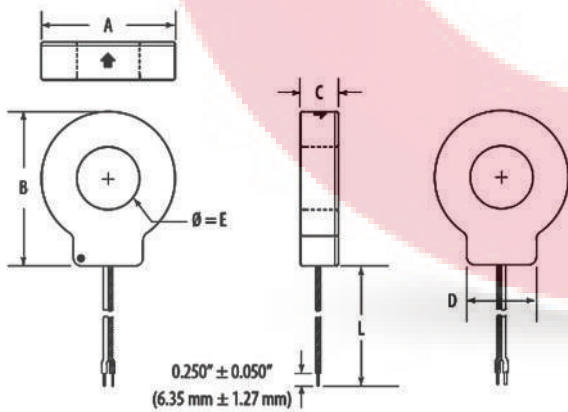

Model	L	A	B	C	D	E
LVCT20050S						
LVCT20100S	1.8 m	33 mm	38 mm	18 mm	21 mm	10 mm
LVCT20202S	1.8 m	59 mm	66 mm	18 mm	31 mm	25 mm
LVCT20403S	1.8 m	70 mm	82 mm	25 mm	36 mm	31 mm

1/3 V low-voltage CT form factor

Small form factor 100/200/300 A	Medium form factor 400/600/800 A	Large form factor 800/1000/1200/ 1600/2000/2400 A
A = 96 mm	A = 125 mm	A = 125 mm
B = 30 mm	B = 73 mm	B = 139 mm
C = 31 mm	C = 62 mm	C = 62 mm
D = 30 mm	D = 30 mm	D = 30 mm
E = 100 mm	E = 132 mm	E = 201 mm
F = 121 mm	F = 151 mm	F = 151 mm

PB113663

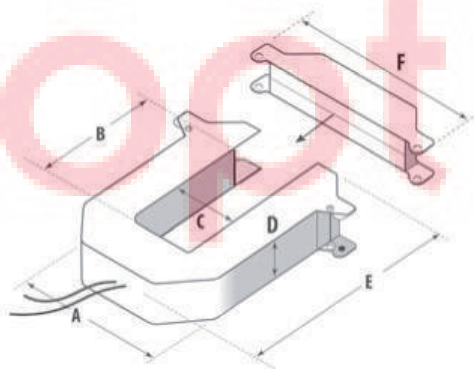

Split-core CT dimensions - see table.

Retrofit & Wireless Products



The advantages of using wireless interfaces throughout your power monitoring system are numerous and proven. Whether you install these products as part of a retrofit upgrade or as modules in a new build environment, ease of installation and commissioning will reap huge economic benefits.

optimizer

Retrofit & Wireless Products

The PowerLogic wireless range is designed to retrofit existing switchboards and enhance the energy efficiency of buildings for many years.

These products are:

- Easy and cost-effective to install
- Able to collect a broad scope of electrical data
- Able to utilize a variety of meters to measure WAGES (Water, Air, Gas, Electricity, Steam) usage
- Transmit all data to a centralized data concentrator for detailed analysis



METSEEM3502



METSEEM4235

PB116451
PB116451

EM3500 series

The EM3500 Series DIN Rail Meter combines exceptional performance and easy installation to deliver a cost-effective solution for power monitoring applications.

The EM35xx can be installed on standard DIN rail or surface mounted as needed. Pulse output and phase alarms provide additional versatility.

Applications

Capable of essential cost management:

- Energy monitoring in building automation systems
- Renewable energy monitoring
- Commercial sub-metering
- Energy management
- Industrial monitoring
- Accurate cost allocation



METSEEM3502

PB105431

The solution for

Markets that can benefit from a solution that includes PowerLogic EM3500 series meters:

- Buildings
- Industry
- Healthcare
- Data Centre and networks
- Infrastructure

Benefits

System integrators' benefit

- Ease of integration
- Ease of setup
- Cost effectiveness

Panel builders' benefit

- Ease of installation
- Cost effectiveness
- Aesthetically pleasing
- Simplified ordering

End users' benefit

- Ease of use
- Precision metering & sub-billing
- Billing flexibility
- Comprehensive, consistent and superior performance

Competitive advantages

- DIN rail mounting option; easy installation
- Real energy output and phase loss alarm output
- 90-600 V AC; application versatility with fewer models to stock
- Bright backlit LCD; easy visibility in dark enclosures
- Data logging capability safeguard during power failures
- EM35xx models compatible with LVCTs from 5 A to 32000 A
- User-enabled password protection prevents tampering
- Native BACnet MS/TP support (no gateway)

Power management solutions

Schneider Electric provides innovative power management solutions to increase your energy efficiency and cost savings, maximise electrical network reliability and availability, and optimise electrical asset performance.

Conformity of standards

- IEC 61557-12
- IEC 61000-4-4
- IEC 62053-22
- IEC 61000-4-5
- IEC 62053-24
- IEC 61000-4-6
- IEC 61010-1
- IEC 61000-4-8
- IEC 61000-4-2
- Etc.
- IEC 61000-4-3

EM3500 series

PB105431



PowerLogic™ EM3500

The data logging capability (EM3555 and EM3560) protects data in the event of a power failure. Modbus, pulse output, and phase alarms are all provided to suit a wide variety of applications. Additional pulse inputs on EM3560 provide an easy way to incorporate simple flow sensors to track gas, water, steam, or other energy forms using a BACnet system in addition to full monitoring of electrical energy.

EM35xxA (Pulse, Modbus, BACnet) models designed for use exclusively with Rogowski coil CTs where integrator and power supply for the CTs are built into the meter, resulting in fewer devices to purchase and faster to install. (Not recommended for high harmonic applications.)

The EM3555 models adds a bi-directional monitoring feature designed expressly for renewable energy applications, allowing measurement of power imported from the utility grid as well as power exported from the renewable energy source (e.g. solar panels). In this way, a facility administrator track all energy data, ensuring accuracy in billing and crediting.

• Features

- All Models: A compact solution for panelboard monitoring
 - DIN rail mounting option; easy installation
 - ANSI 12.20 0.2% accuracy, IEC 62053-22 Class 0.2S for all 35xx models; great for cost allocation
 - ANSI C12.20 0.5% accuracy, IEC 62053-22 Class 0.2S for EM35xxA models
 - Real energy output and phase loss alarm output on EM3502(A), EM3550(A), and EM3555 models; one device serves multiple applications
 - 90-600 VAC; application versatility with fewer models to stock
 - Bright backlit LCD; easy visibility in dark enclosures
 - Data logging capability EM3555 & EM3560(A); safeguard during power failures
 - EM35xx models compatible with LVCTs from 5 A to 32000 A; wide range of service types
 - User-enabled password protection; prevents tampering
 - EM35xxA models are designed to work exclusively with Rogowski coil CTs 20-5000 A range. Eliminate site walks, save time and money. (Not recommended in high harmonic applications.)
 - System integration via Modbus EM355xx(A) or BACnet MS/TP EM356xx(A); convenient compatibility with existing systems
 - Native BACnet MS/TP support (no gateway) with serial rates up to 115.2 kbaud EM3560, EM3561, EM3560A, & EM3561A
- EM3555 Models: An essential solution for Solar and other renewable energy applications
 - Bi-directional metering (4-quadrant); allows net metering
 - Data logging capability; ensures long term data retrieval
 - CSI approved

PB113727

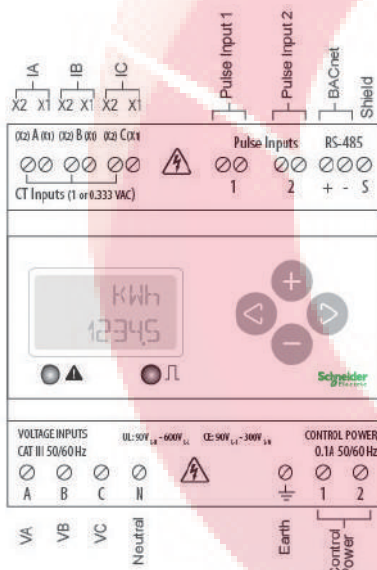

EM3500 parts and connection terminals

PB113728

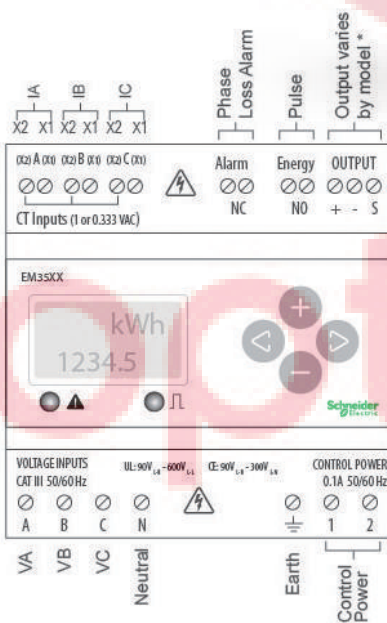

EM3502/EM355x parts and connection terminals

EM3500 series

PE105437



EM3500 in enclosure with door open

Selection guide

Electrical characteristics		
Inputs	Control Power, AC	50/60 Hz; 5 VA max.; 90 V min.; UL Maximums: 600 V L-L (347V L-N); CE Maximums: 300 V L-N (520V L-L)
	Control Power, DC	3W max.; UL and CE: 125 to 300 V DC (external DC current limiting required)
	Voltage Input	UL: 90 V L-N to 600 V L-L ; CE: 90 V L-N to 300 V L
Current Input	Scaling	5 A to 32,000 A Non "A" models only 20 A to 5000 A for "A" models only
	Input Range	1/3V and 1V nominal LVCT (selectable) Non "A" models only Rogowski coil CTs only for "A" models
	Pulse Inputs (EM3560 & EM3560A)	Two sets of contact inputs to pulse accumulators
Accuracy	Real Power and Energy	0.2 % (ANSI C12.20, IEC 62053-22 Class 0.2S) EM35xx models only
		0.5 % (ANSI C12.20, IEC 62053-22 Class 0.5S) EM35xxA models only
Outputs	All Models (EM3560, EM3560A, EM3561 & EM3561A)	Real Energy Pulse: N.O. static; Alarm contacts: N.C. static
	EM3502	Reactive energy pulse 30 VAC/DC
	EM3550, EM3555, EM3550A	RS-485 2-wire Modbus RTU (1200 baud to 38.4 kbaud)
	EM3560, EM3560A, EM3561, EM3561A	RS-485 2-wire BACnet MS/TP (9600 baud to 115.2 kbaud)
Mechanical characteristics		
Mounting		DIN Rail or 3-point screw mount
Environmental conditions		
Operating temperature Range		-30 °C to 70 °C
Storage Temperature Range		-40 °C to 85°C
Humidity Range		<95 % RH non-condensing
Accessories		
NEMA 4x enclosure (EM3500-ENC, pictured)		
Split-core low voltage CTs (LVCTxx)		
Fuse kits (EFP1, EFP2, EFP3)		
Safety		
US and Canada (cULus) UL508 (open type device)/CSA 22.2 No. 14-05		
Europe (CE) EN61010-1:2001		

Feature selection

Commercial reference number	Model	Description
METSEEM3502	EM3502	Pulse out only
METSEEM3550	EM3550	Modbus - 2 quadrant
METSEEM3555	EM3555	Modbus - 4 quadrant with logging
METSEEM3560	EM3560	BACnet with logging
METSEEM3502A	EM3502A	Pulse Rope CT model
METSEEM3550A	EM3550A	Modbus Rope CT Model
METSEEM3560A	EM3560A	BACnet w/ logging Rope CT Model
METSEEM3561	EM3561	BACnet without logging
METSEEM3561A	EM3561A	BACnet without logging Rope CT Model

EM3500 series

EM3500 series	EM3502	EM3550	EM3560	EM3561	EM3555	EM3502A	EM3550A	EM3560A	EM3561A
Measurement Capability, Full Data Set									
Bi-directional Energy Measurements					■				
Power (3-phase total and per phase): Real (kW) Reactive (kVAR), and Apparent (kVA)	■	■	■	■	■	■	■	■	■
Power Factor: 3-phase average & per phase	■	■	■	■	■	■	■	■	■
Present Power Demand: Real (kW), Reactive (kVAR), and Apparent (kVA)	■	■	■	■	■	■	■	■	■
Import and Export totals of Present Power Demand: Real (kW), Reactive (kVAR), & Apparent (kVA)					■				
Peak Power Demand: Real (kW), Reactive (kVAR), and Apparent (kVA)	■	■	■	■	■	■	■	■	■
Current (3-phase average and per phase)	■	■	■	■	■	■	■	■	■
Voltage: Line-Line and Line-Neutral (3-phase average and per phase)	■	■	■	■	■	■	■	■	■
Frequency	■	■	■	■	■	■	■	■	■
ANSI C12.20 0.5 % accuracy, IEC 62053-22 Class 0.5S						■	■	■	■
ANSI C12.20 0.2 % accuracy, IEC 62053-22 Class 0.2S	■	■	■	■	■				
Accumulated Net Energy: Real (kWh), Reactive (kVARh), and Apparent (kVAh)	■	■	■	■	■	■	■	■	■
Accumulated Real Energy by phase (kWh)	■	■	■	■	■				
Import and Export Accumulators of Real and Apparent Energy					■				
Reactive Energy Accumulators by Quadrant (3-phase total & per phase)					■				
Demand Interval Configuration: Fixed or Rolling Block	■	■	■	■	■	■	■	■	■
Demand Interval Configuration: External Sync to Comms		■	■	■	■		■	■	■
Data Logging (Store up to 60 days at 15-minute interval)									
Data Logging: 10 16-Bit Configurable (can include Date/Time) Data Buffers					■				
Data Logging: 3 Timestamped 32-Bit Configurable Data Buffers			■					■	
Outputs									
Alarm Output (N.C.)	■	■	■	■	■	■	■	■	■
1 Pulse Output (N.O.)		■			■		■		
2 Pulse Outputs (N.O.)	■					■			
RS-485 Serial (Modbus RTU Protocol)		■			■		■		
RS-485 Serial (BACnet MS/TP Protocol)			■	■				■	■
LON FT Serial (LonTalk Protocol)									
Inputs									
2 Pulse Contact Accumulator Inputs				■					■
1 Pulse Contact Accumulator Input			■					■	

Display Screen Diagram

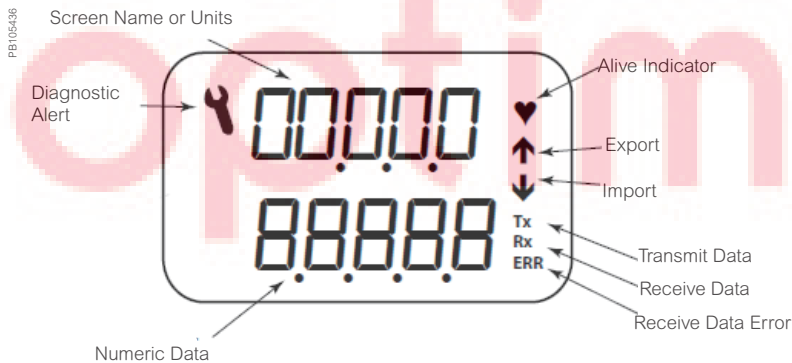

EM3500 series

EM3500 dimensions

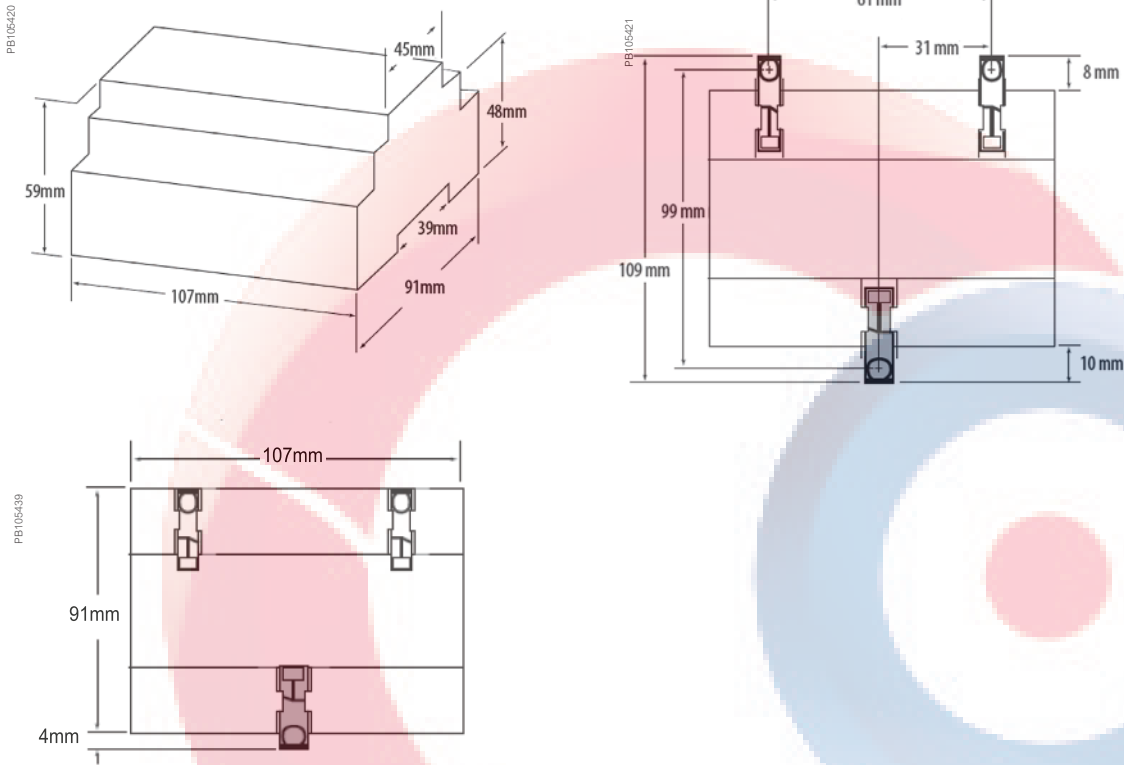

Bottom View (DIN Mount Option)

EM3500 connections

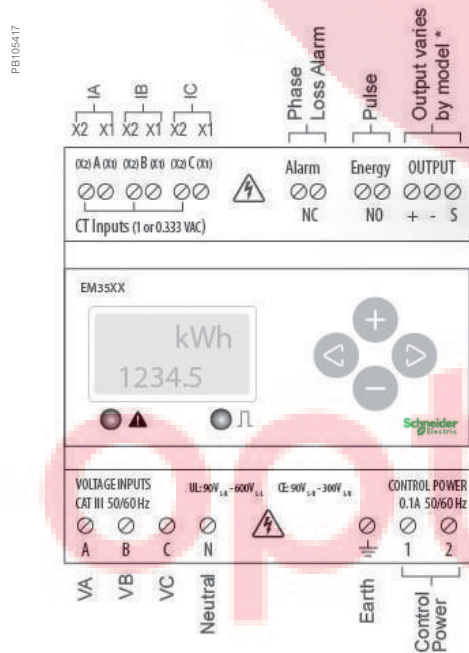

Two 5-character rows of display text.
Top row alphanumeric;
Bottom row numeric only

The red Alarm LED lights when any of the 3 phase voltages drop below the selected threshold.

The green Energy LED lights momentarily each time the Energy output pulse is active.

Please see EM3500 User Guide and EM3500 Installation Guide for safe and correct wiring and connection information.

EM4200 series

The PowerLogic EM4200 Series Enercept power and energy meters provide a unique solution for measuring energy data.

Designed for simplicity, the range includes two main offers: System Calibrated and Flex. The EM4200 System Calibrated offers system accuracy, pre-mounted Current Transducers, with a simple to quote and order single part number.

The EM4200 Flex offers the flexibility of a wide range of Current Transducers to match most applications, no matter how varied.

Applications

Capable of essential cost management:

- Energy monitoring in building automation systems
- Renewable energy monitoring
- Energy management
- Commercial sub-metering
- Industrial monitoring
- Accurate cost allocation



METSEEM4235

PB121803

The solution for

Markets that can benefit from a solution that includes PowerLogic EM4200 series:

- Buildings
- Industry
- Healthcare
- Data centre and networks
- Infrastructure

Benefits

System integrators' benefit

- Ease of integration
- Ease of setup
- Cost effectiveness

Panel builders' benefit

- Ease of installation
- Cost effectiveness
- Aesthetically pleasing
- Simplified ordering

End users' benefit

- Ease of use
- Precision metering & sub-billing
- Billing flexibility
- Comprehensive, consistent and superior performance

Competitive advantages

- High reliability with high system, or meter accuracy.
- Single part to order a metering chain (System Calibrated).
- Supports a large range of Sensor options. Flex can adapt to CTs from 50 to 5000 A, or different Rogowski coil sizes rated for up to 5000 A.
- Modbus and BACnet protocols along with uni-directional and bi-directional feature sets.
- Wide 90 to 480 V AC input range.
- DIN rail or screw-mount options, including mounting bracket for easy installation.
- Seamless integration with EcoStruxure™ Power Management software products.

Power management solutions

Schneider Electric provides innovative power management solutions to increase your energy efficiency and cost savings, maximise electrical network reliability and availability, and optimise electrical asset performance.

Conformity of standards

- CAN/CSA-C22.2
- EN 61326-1 Class A
- EN 61000-6-2
- EN 61000-6-4 Class A
- EN 61010-1
- FCC 47 CFR Part 15 Class A
- UL 61010-1

Accuracy standards

Flex models

- ANSI C12.20-2015 Class 0.2
- IEC 62053-24 Class 1S

When used with 1/3 V CT (Meter accuracy)

- IEC 62053-22 Class 0.2S 0.2%

When used with Rogowski Coils (Meter accuracy)

- IEC 62053-22 Class 0.5S

System calibrated

- ANSI C12.1, 1%
- IEC 62053-22 Class 1S 1%

EM4200 series



EM4200 Flex Power Meter

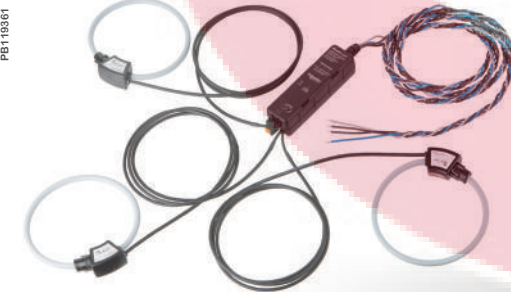

EM4200 System Calibrated with calibrated Rogowski coils

The EM4200 meter series provides a highly flexible retrofit option ideal when adding metering to an existing building, or to integrate in an OEM solution. Designed to simplify the ordering process, the meter is declined in 2 major options:

System Calibrated offers the simplest way to order, deploy and meet requirements. The meter comes with pre-mounted Current Transducers (CT), or Rogowski Coils. A single reference provides a System calibrated accuracy meter with a 100, 200, 400A CT, or 5,000A Rogowski coil.

Flex offers the flexibility required when the CT, or Rogowski coil, rating or size needs to further adapt to the site. CTs can range from 50 to 5,000A and Rogowski coils can be different sizes with a 5,000 A rating.

- General features
 - Uni and Bi-Directional metering to support to power generation application.
 - Data logging.
 - Modbus and BACnet serial communication with auto-protocol and baud rate detection.
 - Configurable with or without power.
 - DIN rail or screw-mount options, including mounting brackets for easy installation.
 - Seamless integration in Power Monitoring Operations and Power SCADA Operations.
 - Wide input range of 90 to 480 V AC.
 - Approvals: UL 61010-1, IEC/EN 61010-1
- System calibrated features
 - Three factory mounted and calibrated Current Transducers (100, 200 or 400 A), or Rogowski coils (5,000 A, 12" or 18" (304.8 mm or 457.2 mm)). Simplifies ordering and commissioning.
 - ANSI version only: Fuse packs factory mounted.
 - System Accuracy from 1% to 100% load:
 - Real Power and Energy: ANSI C12.1 1%, IEC 62053-22 Class 1S, 1%.
 - Reactive Power and Energy: IEC 62053-24 Class 1, 1%
- Flex features
 - Supports generic 1/3 V CTs from 50 to 5,000 A. Or 1/3 V 5,000 A Rogowski coils.
 - ANSI: Optional fuse packs available.
 - Meter Accuracy from 1% to 100% of load (CT mode):
 - Real Power and Energy: ANSI C12.20 0.2%, IEC 62053-22 Class 0.2S, 0.2%.
 - Reactive Power and Energy: IEC 62053-24 Class 1, 1%.

optimizer

EM4200 series

EM4200 series selection guide

Advantage	EM4200 Flex		EM4200 System Calibrated			
	METSEEM4235	METSEEM4236	METSEEM4235Axx	METSEEM4236Axx	METSEEM4235Bxx	METSEEM4236Bxx
General						
Market	IEC	ANSI	IEC	ANSI	IEC	ANSI
Single part to order			Yes	Yes	Yes	Yes
Factory mounted CTs/Rogowski coil			Yes	Yes	Yes	Yes
CT						
Rating	50 to 5000 A user choice	50 to 5000 A user choice	Three		Three 100, 200 or 400 A supplied	Three 100, 200 or 400 A supplied
Type	1/3 V Solid or Split Core	1/3 V Solid or Split Core			Split Core	Split Core
Rogowski Coil						
Rating	5000 A	5000 A	5000 A supplied	Three 5000 A supplied		
Type						
Size	User choice	User choice	12" or 18"	12" or 18"		
Accuracy						
Meter	0.2% with CTs 0.5% with Rogowski Coil	0.2% with CTs 0.5% with Rogowski Coil				
System			1%	1%	1%	1%
Fuse pack						
	Option sold separately	Option sold separately		Factory mounted		Factory mounted
Communication						

EM4200 parts descriptions and advantages

EM4200 Flex meter

EM4200 System calibrated

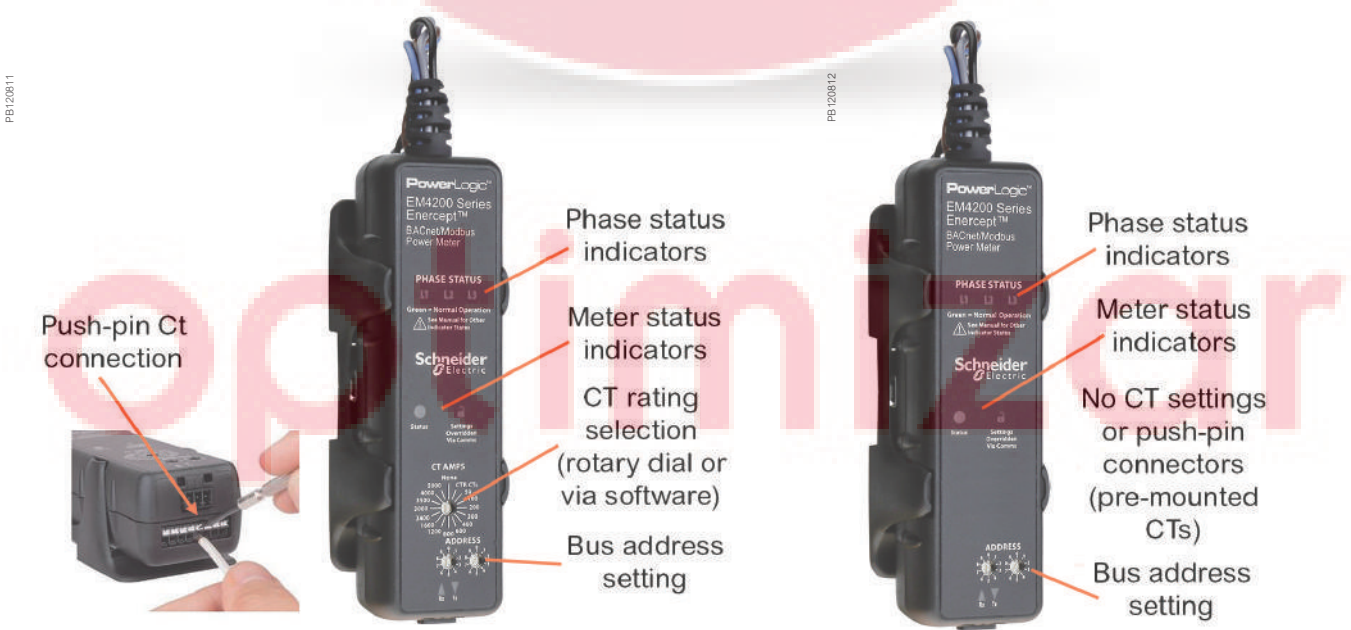

PE120811

PE120812

EM4200 series

Electrical characteristics		EM4200 Flex	EM4200 System calibrated
Input-voltage characteristics	Inputs	V1, V2, V3, Vn	V1, V2, V3, Vn
	Measured voltage	90 - 277 V AC L-N UL max 480 V L-L CE max 300 V L-N	90 - 277 V AC L-N UL max 480 V L-L CE max 300 V L-N
	Frequency range	50/60 Hz	50/60 Hz
Mechanical characteristics			
Weight		Approx 1/0 kg (2.2 lb)	1.4 to 2.2 Kg (3.10 to 4.85 lb) (model dependent)
Dimensions		46.63 x 35.81 x 152.36 mm (1.84 x 1.41 x 6.0 in)	46.63 x 35.81 x 152.36 mm (1.84 x 1.41 x 6.0 in) (Meter alone), CT/Rogowski size varies with model
Environmental conditions			
Operating temperature		-30 °C to 70 °C (-22 to 158 °F)	0 to 70 °C (32 to 158 °F)
Storage temperature		-40 °C to 85 °C (-40 to 185 °F)	With Split Core CTs: -40 to 85 °C (-40 to 185 °F) With Rogowski Coils: -40 to 70 °C (-40 to 158 °F)
Humidity rating		<95 % RH non-condensing	<95 % RH non-condensing
Enclosure		Indoor use only - not suitable for wet locations	Indoor use only - not suitable for wet locations
Altitude		3000 m (10,000 ft)	3000 m (10,000 ft)
Pollution degree		2	2
Electromagnetic compatibility Compliance			
		CAN/CSA-C22.2 EN 61000-6-2 EN 61000-6-4 Class A EN 61010-1 EN 61326-1 Class A FCC 47 CFR Part 15 Class A UL 61010-1	CAN/CSA-C22.2 EN 61000-6-2 EN 61000-6-4 Class A EN 61010-1 EN 61326-1 Class A FCC 47 CFR Part 15 Class A UL 61010-1
Accuracy			
		ANSI C12.20-2015 Class 0.2	ANSI C12.20-2015 Class 0.2
		IEC 62053-24 Class 1S	IEC 62053-24 Class 1S
		ANSI C12.20 2015 Class 0.2 IEC 62053-24 Class 1S When used with 1/3 V CT (Meter accuracy) IEC 62053-22 Class 0.2S 0.2% When used with Rogowski coils (Meter accuracy) IEC 62053-22 Class 0.5S	ANSI C12.1 1% IEC 62053-21 Class 1S 1% IEC 62053-24 Class 1 1%

Commercial Reference Numbers

Market	Commercial Reference	Rating	CTR type	CT size	Fuse pack	CT lead length	System calibrated
IEC	METSEEM4235	User choice					
IEC	METSEEM4235A12	Up to 5000 A (3 coils supplied)	Rogowski	12" (304.8 mm)		6 ft (1828.8 mm)	Yes
IEC	METSEEM4235A18	Up to 5000 A (3 coils supplied)	Rogowski	18" (457.2 mm)		6 ft (1828.8 mm)	Yes
IEC	METSEEM4235B101	100 A (3 CTs supplied)	Split core			6 ft (1828.8 mm)	Yes
IEC	METSEEM4235B201	200 A (3 CTs supplied)	Split core			6 ft (1828.8 mm)	Yes
IEC	METSEEM4235B401	400 A (3 CTs supplied)	Split core			6 ft (1828.8 mm)	Yes
ANSI	METSEEM4236	User choice			Option		
ANSI	METSEEM4236A12	Up to 5000 A (3 coils supplied)	Rogowski	12" (304.8 mm)	Yes	6 ft (1828.8 mm)	Yes
ANSI	METSEEM4236A18	Up to 5000 A (3 coils supplied)	Rogowski	18" (457.2 mm)	Yes	6 ft (1828.8 mm)	Yes
ANSI	METSEEM4236B101	100 A (3 CTs supplied)	Split core		Yes	6 ft (1828.8 mm)	Yes
ANSI	METSEEM4236B201	200 A (3 CTs supplied)	Split core		Yes	6 ft (1828.8 mm)	Yes
ANSI	METSEEM4236B401	400 A (3 CTs supplied)	Split core		Yes	6 ft (1828.8 mm)	Yes

EM4200 series

EM4200 dimensions

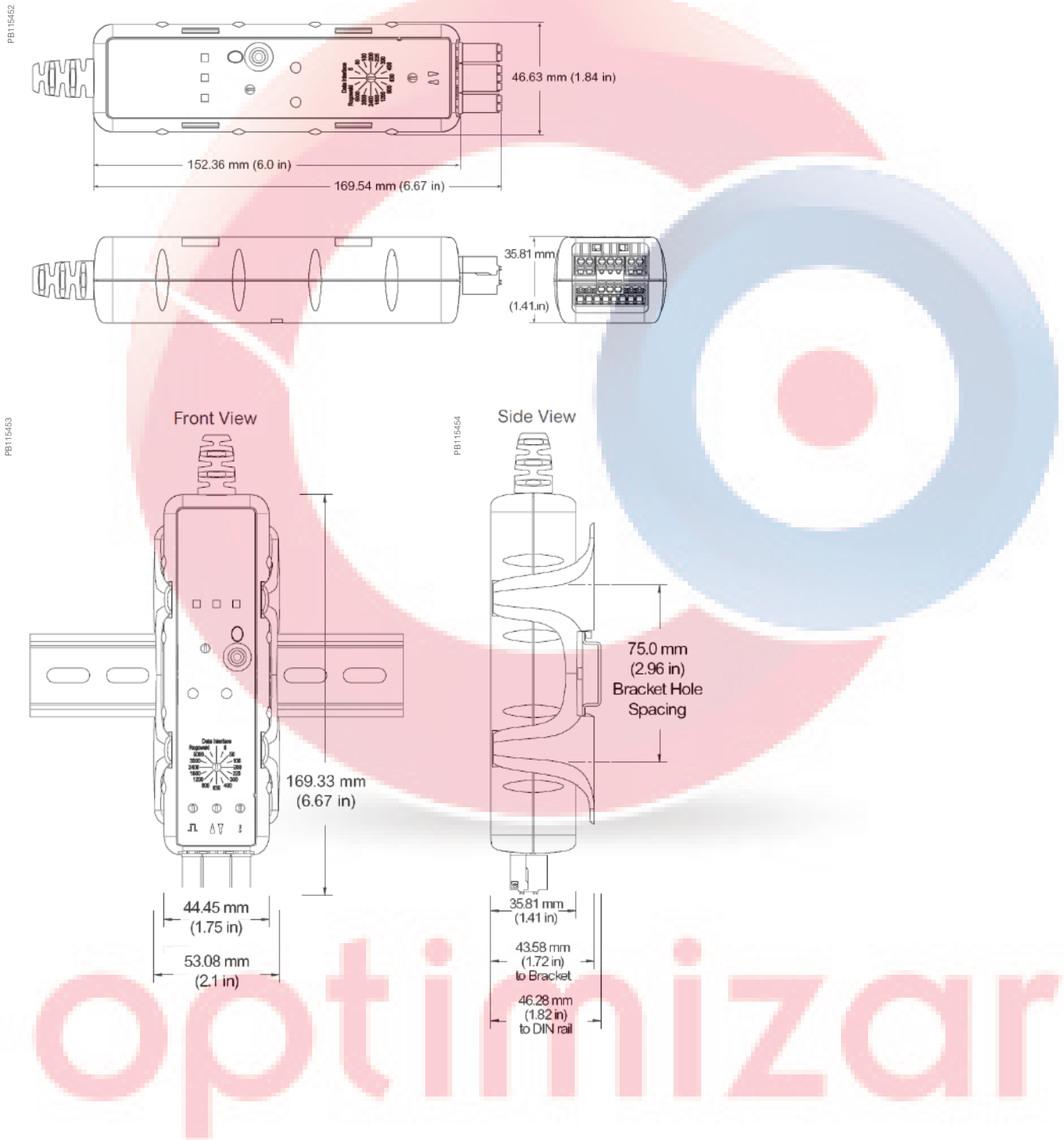



Communications & Gateways

This is a part of your metering solution which provides an interface between energy monitoring software and your metering points via GPRS, wired connection and Wi-Fi. We also offer the option of an integrated gateway-server which provides an all-in-one energy management solution. They are fully capable of supporting EcoStruxure™ Power Management software.

optimizer

Communications & Gateways

Data loggers, gateways and remote terminal units help measured data reach the power monitoring software for analyses.

They are fundamental components in most power and energy management system architectures.

- Link150 Ethernet gateway
- Data logger Com'X 210
- Data logger Com'X 510
- ION7550 RTU

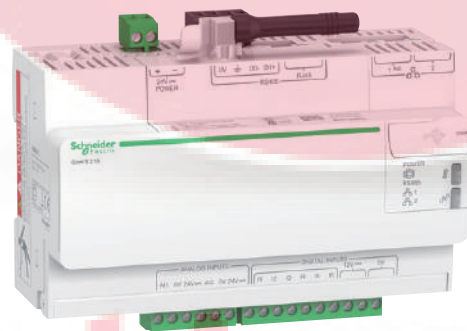

optimizer



EGX150



EBX210



P765CA0A

Serial link

With Schneider Electric’s advanced communication technology, all forms of power monitoring data can be accessed remotely, quickly and easily.

In all architectures, the communication interface serves as the link between the installation devices and the PC running the operating software. It provides the physical link and protocol adaptation. Adaptation is required because the communication systems used by the PC (Modbus via RS-232 and/or Ethernet) are generally not those used by the installation devices (e.g. the Modbus protocol via RS-485).

Dedicated application software prepares the information for analysis under the best possible conditions.

In addition, an Modbus-Ethernet gateway in serial port slave mode allows a serial Modbus master device to access information from other devices across a Modbus TCP/IP network.

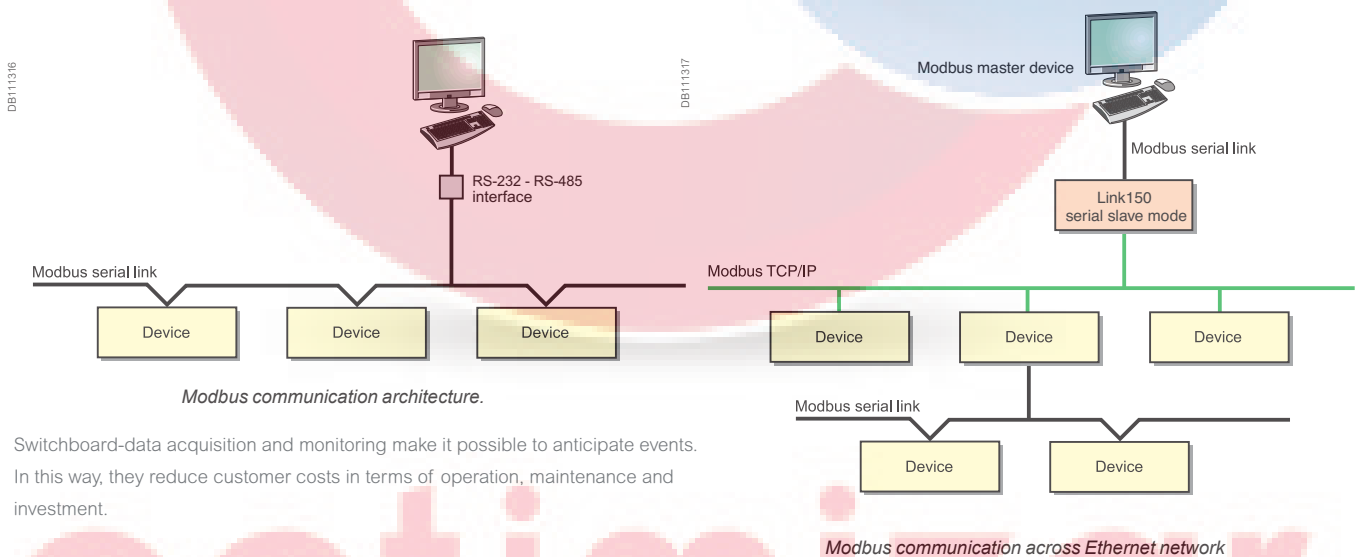

Switchboard-data acquisition and monitoring make it possible to anticipate events. In this way, they reduce customer costs in terms of operation, maintenance and investment.



Ethernet link

Using modern web technologies, the operator can access information from monitoring and protection devices using any PC connected to the network, with all the required security.

The Ethernet Modbus-Ethernet gateway* or the integrated gateway-servers* provide connectivity between Modbus RS-485 and Ethernet Modbus TCP/IP.

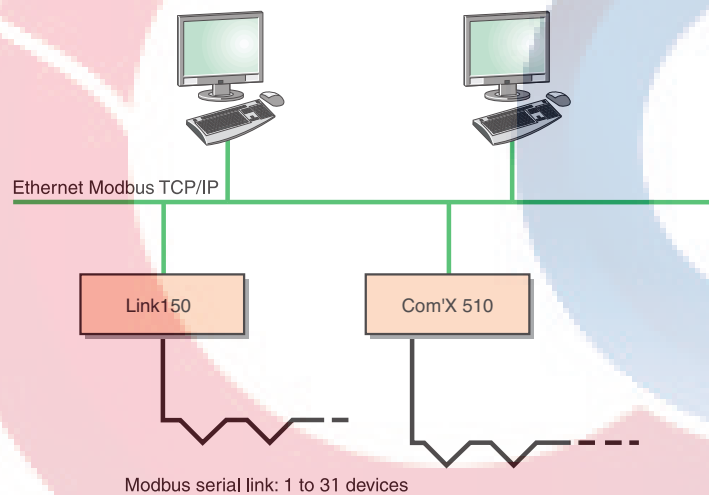

Ethernet communication architecture.

The services available with these technologies considerably simplify the creation, maintenance and operation of these supervision systems.

The application software is now standardised: the web interface into the system does not require custom web pages to be created. It is personalised by simply identifying the components in your installation and can be used as easily as any internet application.

The first step in this approach is the integrated gateway-server with HTTP pages. Power management software (EcoStruxure™ Power Monitoring Expert and EcoStruxure™ Power SCADA Operation), running on a PC, provide broader coverage for more specific need

Link150 Ethernet gateway

The Link150 gateway provides fast, reliable Ethernet connectivity in the most demanding applications, from a single building to a multi-site enterprise. This gateway supports meters, monitors, protective relays, trip units, motor controls and other devices that need to communicate data quickly and efficiently. It is your simple, cost-effective serial line to full Ethernet connectivity.

Applications

- Energy management
- Power distribution
- Building automation
- Factory automation

PB115427

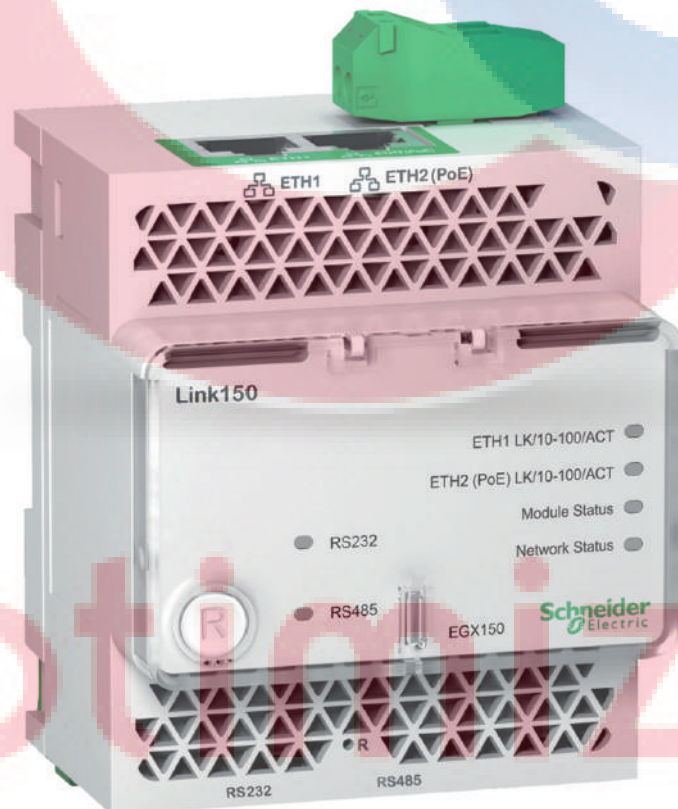

EGX150

The solution for

All markets that can benefit from a solution that includes the Link150 gateway:

- Buildings
- Data centre
- Healthcare
- Industry
- Infrastructure
- Utility

Benefits

- Easy to install and setup
- Easy to maintain
- Advanced security feature
- Compatible with Schneider Electric software offerings
- Reliable Modbus to Ethernet protocol conversion

Energy and power management software

Powerlogic software is recommended as a user interface which provides access to all status and measurement information. It also prepares summary reports for energy and power management. The Link150 is compatible with

- EcoStruxure™ Power Monitoring Expert software
- EcoStruxure™ Power SCADA Operation

Conformity of standards

- EN 55022/EN 55011/ FCC Class A
- EN 61000-6-2
- EN 61000-4-2
- EN 61000-4-3
- EN 61000-4-4
- EN 61000-4-5
- EN 61000-4-6
- EN 61000-4-8
- EN 60950

Architecture

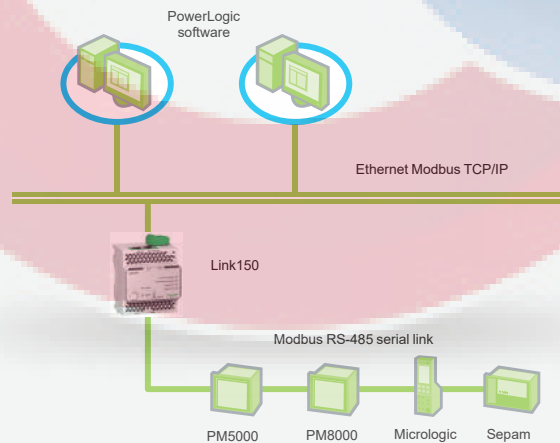

Security

- Secure user interface including user's name and password for login
- Advanced security features to allow users to specify which Modbus TCP/IP master devices may access attached serial slave devices
- Modbus TCP/IP filtering feature
- Allows user to specify the level of access for each master device as Read-only or Full access
- Web pages provide easy configuration and setup

Commercial ref. no.	Product description
EGX150	Link150 Ethernet Gateway

Link150 Ethernet gateway

Technical specifications

Link150	
Weight	175 g without packing
Dimensions (HxWxD)	72 x 105 x 71 mm
Mounting	DIN rail
Power-over-Ethernet (PoE)	Class 3
Power supply	24 V DC (-20/+10 %) or Power over Ethernet (PoE Class 3 IEEE 802.3 af) at 15 W
Consumption (typical)	24 V DC, 130 mA at 20 °C PoE 48 V DC, 65 mA at 20 °C
Ambient operating temperature	-25 to 70 °C
Ambient storage temperature	-40 to 85 °C
Humidity rating	5 % to 95 % relative humidity (without condensation) at +55°C
Pollution Degree	Level 2
IP Ratings	On the front panel (wall-mounted enclosure): IP4x Connectors: IP20 Other parts: IP30
Regulatory/standards compliance for electromagnetic interference	
Emissions (radiated and conducted)	EN 55022/EN 55011/FCC class A
Immunity for industrial environments:	
electrostatic discharge	EN 61000-6-2
radiated RF	EN 61000-4-2
electrical fast transients	EN 61000-4-3
surge	EN 61000-4-4
conducted RF	EN 61000-4-5
power frequency	EN 61000-4-6
magnetic field	EN 61000-4-8
Regulatory/standards compliance for safety	
Safety - IEC	IEC 60950
Safety - UL★	UL 60950 UL 61010-2-201
EMC	IEC 6100-6-2
Australia	C-tick - RCM
Sustainability	Green Premium
Serial ports	
Number of ports	2 (1 available at a time)
Types of ports	RS-232 or RS-485 (2-wire or 4-wire), depending on settings
Protocol	Modbus, Serial
Baud rates	19200 bps (factory setting), 2400 bps, 4800 bps, 9600 bps, 38400 bps, 56000 bps★★, 57600 bps★★
Maximum number of connected devices	32 (directly) 247 (indirectly)
Ethernet ports (used as a switch)	
Number of ports	2
Type of port	10/100BASE-TX (802.3af) por
Protocol	HTTP, Modbus TCP/IP, FTP, SNMP (MIB II)

★ Dual listed for US and Canada

★★ Only available when Physical Interface is set to RS-232 and Transmission Mode is set to Modbus ASCII

Link150 Ethernet gateway

Parts

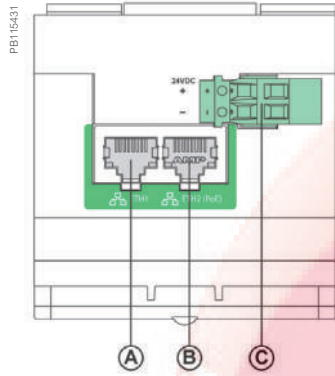

- (A) Ethernet 1 communication port
- (B) Ethernet 2 (PoE) communication port
- (C) Midspan PoE injector

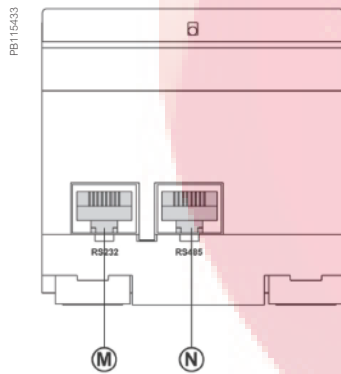

- (M) RS-232 port
- (N) RS-485 port

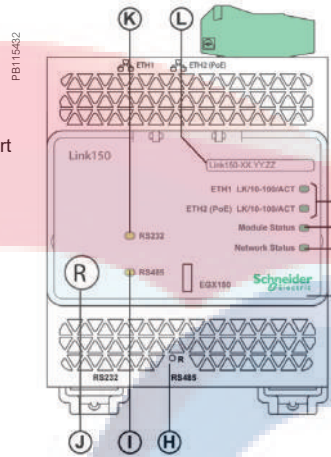

- (D) Ethernet communication LEDs
- (E) Module status LED
- (F) Network status LED
- (G) Scalable transparent cover
- (H) Reset pin
- (I) RS-485 traffic status LED
- (J) Device soft restart button (Accessible through closed cover)
- (K) RS-232 traffic status LED
- (L) Device name label

Dimensions

DIN rail mounting

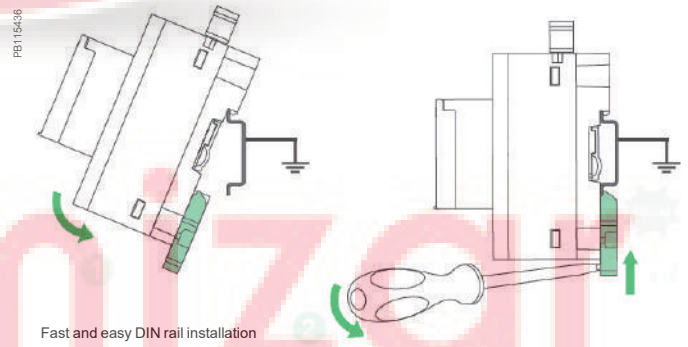
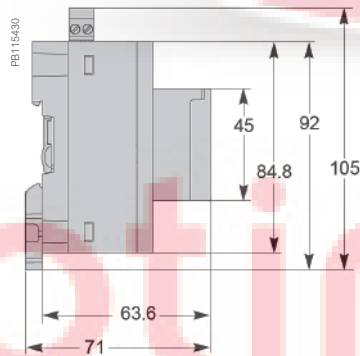
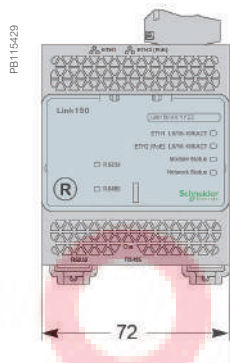

Fast and easy DIN rail installation
See appropriate Installation Guide for this product.

Com'X 210

A highly flexible plug-and-play Energy Server Com'X 210 collects and stores WAGES consumptions and environmental parameters such as temperatures, humidity and CO₂ levels in a building. Data is periodically transmitted as a report to an internet database server for further processing. The Energy Server Com'X 210 not only reduces your technical complexity, but helps to manage your energy.

Applications

The quickest path to multi-site energy management and on-line services

- Delivers batches of data ready to process by EcoStruxure™ Power Management solutions and services
- Publishes logged data to the Schneider Electric cloud or another hosted platform

PB112041

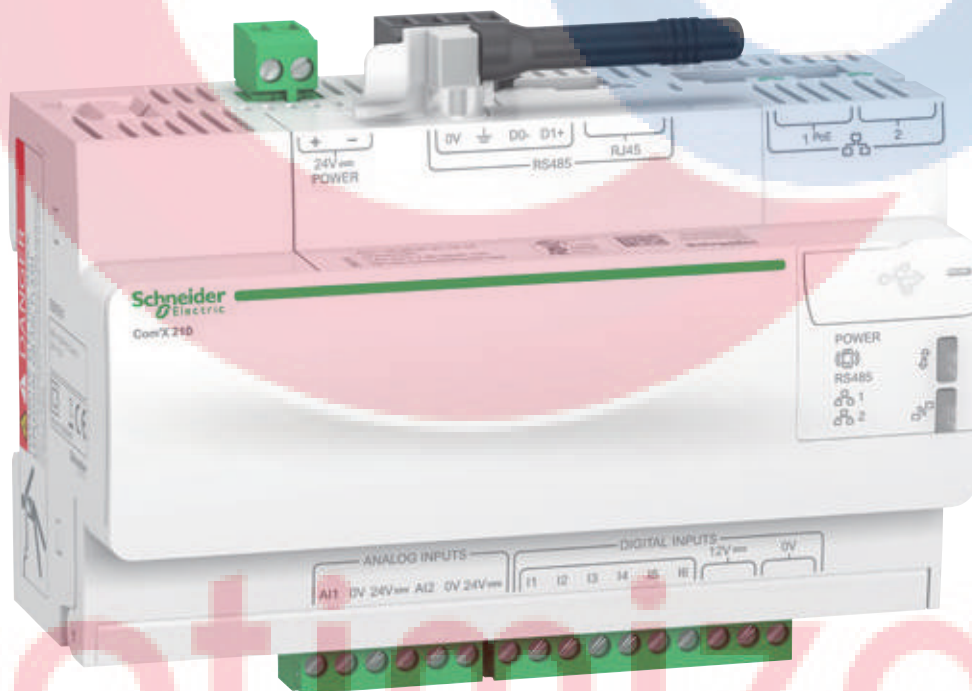

EBX210

The solution for

All markets that can benefit from a solution that includes data logger Com'X 210:

- Buildings
- Industry

Benefits

- Data collection from up to 64 field devices
- Data publishing leveraging existing infrastructures, Ethernet or Wi-Fi, GPRS-ready
- Quick fitting into electrical switchboards thanks to DIN rail clipping and profile
- Quick setup and configuration thanks to intuitive HMI

Energy management solutions

The data collected and stored by Com'X 210 can be processed and displayed as webpages through web services provided by Schneider Electric, such as EcoStruxure™ Power Management software products, or by any private energy platform.

The Com'X 210 also provides a transparent interface between Ethernet-based networks and field devices. This gateway function supports the use of monitoring software, such as EcoStruxure™ Power Monitoring Expert (PME) for data collection, trending, event management, analysis and further processing.

Conformity of standards

- EN 60950

Architecture

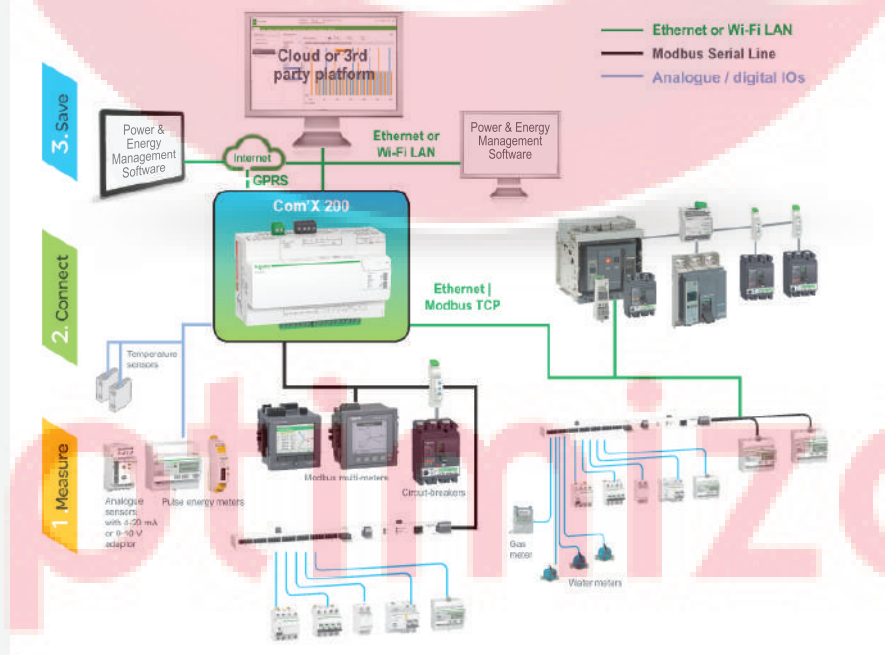

PB114856-200

Data collector

Collects and stores energy data from up to 64 field devices, connected to either:

- Ethernet TCP/IP field network.
- Modbus Serial line network (up to 32 devices).
- Embedded digital and analogue inputs.

“Field devices” consist of :

- PowerLogic devices for power and energy monitoring.
- Masterpact or Compact circuit-breakers for protection and monitoring.
- Acti9 protection devices, meters, remote controlled switches, etc.
- Water, Air, Gas, Electricity, and Steam (WAGES) consumption meters, from specialised manufacturers, delivering pulses as per standard (see table next page).
- Environmental sensors such as temperatures, humidity, and CO₂ levels in a building, providing analogue information.

Data logging and storage capabilities include:

- Configurable logging interval, from every minute to once a week.
- Data storage duration of several weeks, depending on quantity of collected data.

Data publisher

Batches of collected data periodically transmitted to an Internet server, as:

- XML files, for processing by EcoStruxure™ Power Management software products.
- CSV files for viewing in Excel or transformed for upload into programs such as EcoStruxure™ Power Monitoring Expert or any compatible software.

Data publishing function supports 4 transfer protocols over Ethernet or Wi-Fi:

- HTTP
- FTP
- HTTPS
- SMTP

Additional functions

Gateway

If selected by the user, the Com’X 210 can also make all data from connected devices available in real-time:

- In Modbus TCP/IP format over Ethernet or Wi-Fi.
- For requests by an energy management software.

Modbus packets can be sent from managing software to field devices through Modbus serial line or Modbus TCP/IP over Ethernet.

Commercial ref. no.	Product description
EBX210	Com’X 210 data logger 24 V DC or 230 V AC power supplied
EBXA-ANT-5M	Com’X External GPRS antenna

optimizer

Com'X 510

A highly flexible plug-and-play Energy Server Com'X 510 collects and stores WAGES consumptions and environmental parameters such as temperatures, humidity and CO₂ levels in a building. The Com'X 510 has up to 2 year data storage and embedded webpages which means all your energy data can be viewed and managed on-site.

Applications

- All-in-one-box energy management solution especially suitable for buildings up to 10,000 sq. metres

PB114582

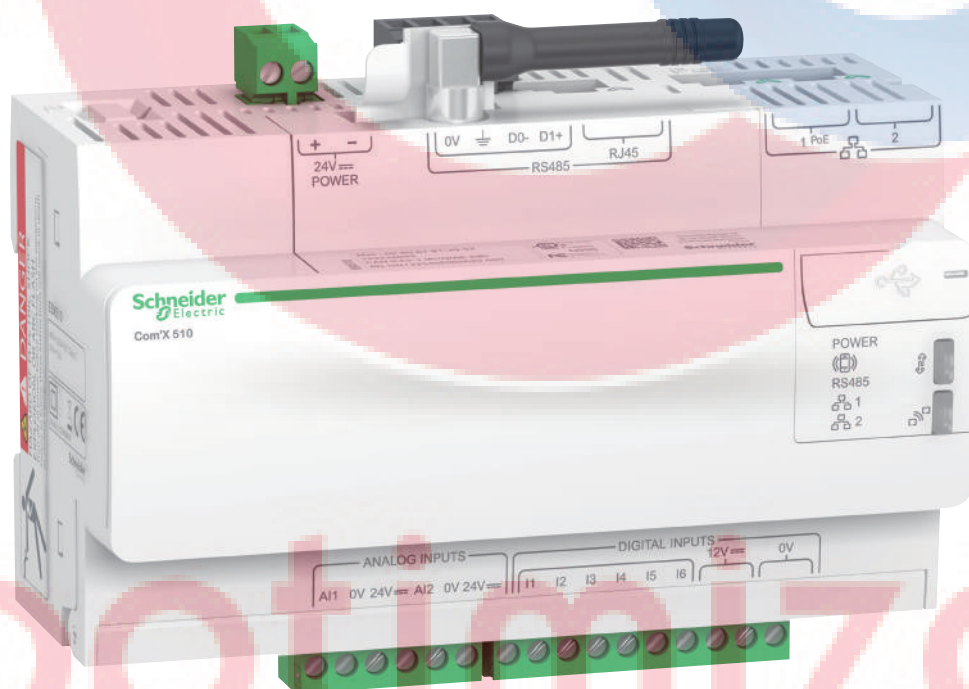

EBX510

The solution for

All markets that can benefit from a solution that includes data logger Com'X 510:

- Buildings
- Industry

Benefits

- Data collection from up to 64 field devices
- Data publishing leveraging existing infrastructures : Ethernet or Wi-Fi, GPRS-ready
- Quick fitting into electrical switchboards thanks to DIN rail clipping and profile.
- Quick setup and configuration thanks to intuitive HMI

Competitive advantages

- Fit any PDU or RPP design for both new and retrofit projects
- Class 1.0 system accuracy
- Ethernet communication

Energy management solution

The data collected and stored by Com'X 510 can be processed and displayed through its own onboard webpage.

The Com'X 510 also provides a transparent interface between Ethernet-based networks and field devices. This gateway function supports the use of monitoring software, such as EcoStruxure™ Power Monitoring Expert for data collection, trending, event management, analysis and further processing.

Conformity of standards

- EN 60950

Architecture

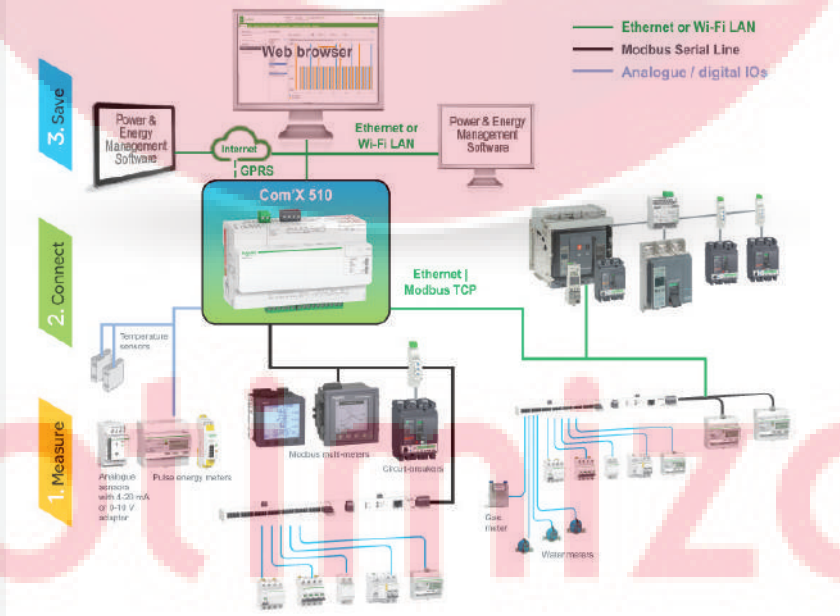

PB114856

Com'X 510 Energy server

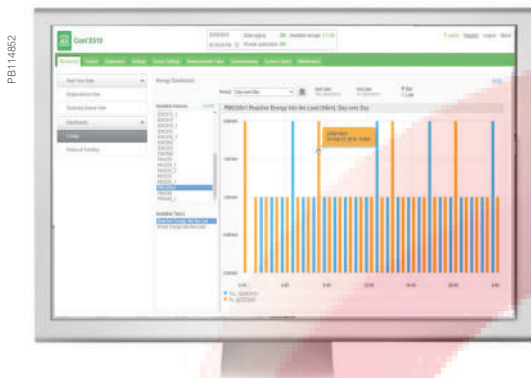

Energy dashboard comparing accumulated over time energy values (partial screen)

Data collector

As soon as the data logger is connected to the LAN, it can be detected and assigned an IP address by DHCP. Your operating system's DPWS feature allows your computer to automatically recognise the device as Com'X. Embedded web pages are then immediately accessible by clicking each Com'X device icon or by typing the assigned IP address into your web browser.

Collects and stores energy data from up to 64 field devices, connected to either:

- Ethernet TCP/IP field network.
- Modbus Serial line network (up to 32 devices).
- Embedded digital and analogue inputs.

"Field devices" consist of:

- PowerLogic meters for power and energy monitoring.
- Masterpact, Powerpact, or Compact circuit-breakers for protection and monitoring.
- Acti9 protection devices, meters, remote controlled switches, etc.
- Water, Air, Gas, Electricity, and Steam (WAGES) consumption meters, from specialised manufacturers, delivering pulses as per standard (see table at end of this document).
- Environmental sensors such as temperatures, humidity, and CO₂ levels in a building, providing analogue information.

Data logging and storage capabilities include:

- Data logging period: configurable from every minute to once a week.
- Data storage duration: up to 2 years, depending on quantity of collected data.
- Able to set time and send reset instructions to field devices.

Embedded energy management software

The Com'X provides the end-user with immediate visibility into energy consumption throughout the site. As soon as the Com'X is connected to the Local Area Network (LAN), several web pages are accessible via any standard web browser, (without plug-in or additional components).

These web pages display real-time data as it is collected, in easy to understand tabular and summary formats. In addition, users can get simple analysis of historical data in bar graph or trending formats.

optimizer

Com'X 510 Energy server

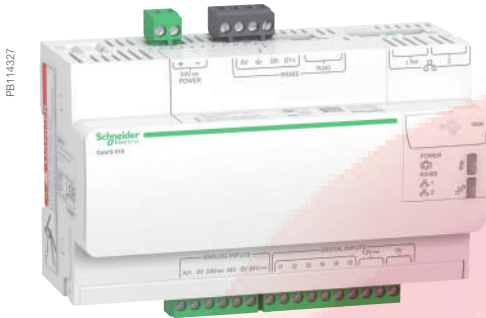

Energy Server Com'X 510 data logger

Additional functions

Data publisher

Batches of collected data can also be periodically transmitted to an Internet server, as:

- XML files, for processing by EcoStruxure™ Power Management software products
- CSV files for viewing in Excel or transformed for uploading to programs such as EcoStruxure™ Power Monitoring Expert or any compatible software

Data publishing function supports 4 transfer protocols over Ethernet or Wi-Fi:

- HTTP
- HTTPS
- FTP
- SMTP

Gateway

- If selected by the user, the Com'X 510 can make data from connected devices available in real time
- In Modbus TCP/IP format over Ethernet or Wi-Fi
- For requests by energy management software



Raw data and measurements from one field device (partial screen)

Modbus packets can be sent from managing software to field devices through Modbus serial line or Modbus TCP/IP over Ethernet.

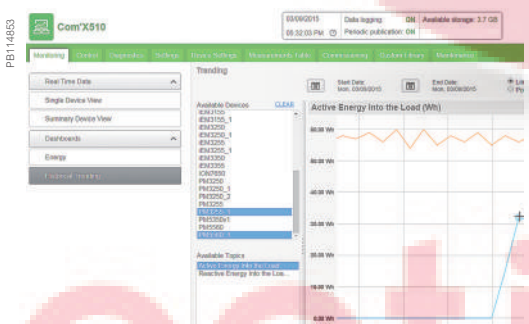

Historical trending comparing multiple devices or multiple topics (partial screen)

Commercial reference numbers	Description
EBX510	Com'X 510 energy server 24 V DC power supplied UL rated
EBXA-ANT-5M	Com'X External GPRS antenna
EBXA-USB-Zigbee	Com'X Zigbee USB interface

Com'X 210/510 Data Logger

PB112047

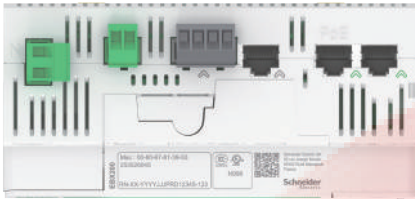

Connection points

- 1 Terminal block
- 2 RJ45 cable
- 3 Ethernet port #1
- 4 Ethernet port #2

PB114859



Power supply to analogue and digital inputs

PB112042



GPRS modem

PB112045



GPRS antenna

Connectivity

- Modbus SL / RS-485 connections to field devices
 - By cable with RJ45 connector.
- 2 Ethernet ports
 - Used to either separate upstream connection from field devices network or to daisy chain Ethernet devices.
 - RJ45 10/100BASE connectors.
 - Static IP address.
- Ethernet port #1
 - Connection to Local Area Network (LAN).
 - PoE Class 3 (802.3af) can act as main/backup power supply for the Com'X.
 - DHCP client.
- Ethernet port # 2
 - Connection to field devices.
 - DHCP client or server.
- Power supply to analogue and digital outputs
 - Outputs to supply sensors and inputs when Com'X is supplied through 24 V DC input on top:
 - 12 V DC 60 mA for digital inputs.
 - 24 V DC for analogue inputs.
 - Compliant with electrical switchboard environment (temperature, electromagnetic compatibility).
- 2 inputs for analogue sensors
 - PT100 or PT1000 temperature probes.
 - Various sensors (humidity, CO₂, etc.) with 0-10 V output.
 - Various sensors with 4-20 mA output
- 6 inputs for dry contact sensors or pulse counters
 - Max 25 pulses per second (min duration 20 ms)
 - IEC 62053-31 Class A
- GPRS modem
 - For connection to the data processing server through cellular or user's APN network.
 - Also connect to Schneider Electric's Digital Service Platform.
 - Especially suitable for sites with no internet access.
 - Simply plugs into dedicated port under the front cover.
- GPRS antenna
 - Improves GPRS signal strength in case of poor transmission conditions.
 - Recommended for Com'X located inside metallic electrical panels.

optimizer

Com'X 210/510 setup and configuration

Setup and configuration

Connection to LAN

As soon as they are connected to the LAN, Com'X devices can be detected and assigned an IP address by DHCP. Your operating system's DPWS feature allows your computer to automatically recognise the device as Com'X. Embedded web pages are then immediately accessible by clicking each Com'X device icon or by typing the assigned IP address into your web browser.

Field device auto-discovery

The user-activated device discovery function automatically identifies all field devices connected to Modbus SL, Ethernet port.

- Schneider Electric devices display with the product image.
- Other devices appear as "unknown," allowing the user to manually assign a device type.
- User can assign their own device types.
- Users can complete additional device identification fields, such as circuit ID or building zone.

Data selection for logging and publication

Web page configuration tabs allow you to configure, in just a few clicks, which connected field devices collect and publish data.

- Advanced diagnostics and troubleshooting features
- Modbus serial and TCP/IP device statistics.
- Ethernet network statistics.
- Communications check wizard.
- Direct reading of register values from local and remote devices.

Additional features and benefits

- Cybersecurity - works well with your cyber security architecture.
- 2 Ethernet ports to separate upstream cloud connection, or to daisy chain with other Ethernet devices, from field device network.
- Data storage in case of communications failure.
- Local backup of configuration parameters - back up your system to a USB storage device and have it available for system restore or to duplicate the configuration on another box.



Device settings page (partial), as displayed after auto-discovery, enabling user to assign circuit identifications and select data for logging and publication.

Com'X 210/510 installation

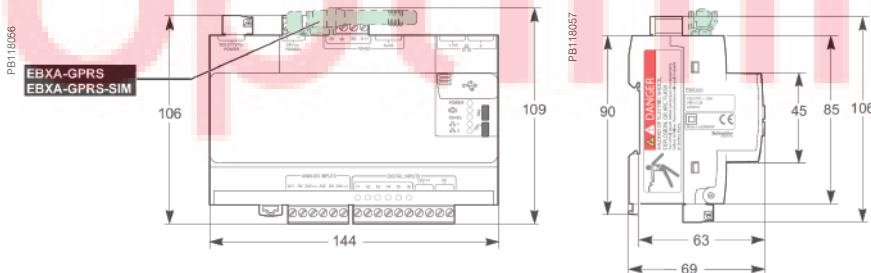

DIN rail fitting (Front face IP40, terminals IP20).

Com'X 210/510 Data Logger

Technical specifications

Com'X 210/510 Environment

Operating temperature	-25° to 60°C Com'X 210 -25° to 70°C Com'X 510
Storage temperature	-40° to 85°C
GPRS dongle Operating temperature	-20° to 60°C
GPRS dongle Storage temperature	-40° to 85°C
Wif-Fi dongle Operating temperature	0° to 50°C
Wi-Fi dongle Storage temperature	-20° to 80°C
Humidity	5 to 95 % relative humidity (without condensation) at 55°C
Pollution	Class III

Safety standards / regulation

International (CB scheme)	IEC 60950
USA	UL 508
USA	UL 60950 (Com'X 510 only)
Canada	cUL 60950 (Com'X 510 only)
Canada	cULus 508
Europe	EN 60950

Quality Brands

CE, UL

Power Supply		Com'X 210	Com'X 510
AC	100-230 V (+/- 15%)(50-60 Hz)	■	
DC	24 V (+/- 10%)	■	■
Power over Ethernet	15.4 W DC	■	■
Max power	26 W max	■	■
Mechanical		Com'X 210	Com'X 510
IP	Front face IP40, terminals IP20	■	■
Dimensions (HxWxD)	91 x 144 x 65.8 mm	■	■
Weight	450 g	■	■

ION7550 RTU

The PowerLogic ION7550 RTU (remote terminal unit) is an intelligent web-enabled device ideal for combined utilities metering of water, air, gas, electricity and steam (WAGES). When combined with Power management software, the ION7550 RTU offers a seamless, end-to-end WAGES metering solution.

Featuring a large, high-visibility display and overall versatility of the PowerLogic system, the ION7550 RTU provides extensive analogue and digital I/O choices and is a cost-effective dedicated WAGES solution when compared to a traditional meter. The device automatically collects, scales and logs readings from a large number of connected meters or transducers and delivers information to one or more head-end systems through a unique combination of integrated Ethernet, modem or serial gateways.

Applications

- WAGES (water, air, gas, electricity, steam) metering
- Integrated utility metering with advanced programmable math functions
- Data concentration through multi-port, multi-protocol communications
- Equipment status monitoring and control
- Programmable set points for out-of-limit triggers or alarm conditions



PE88117

The solution for

All markets that can benefit from a solution that includes PowerLogic ION7550 RTU series meters:

- Buildings
- Industry
- Healthcare
- Education
- Etc.

Benefits

- Help reduce waste and optimise equipment operation to increase energy efficiency
- A large, intuitive display
- Extensive digital and analogue I/O
- Dedicated WAGES solution when compared to a traditional meter

Competitive advantages

- Data concentration through multi-port, multi-protocol communications
- Integrated utility metering with advanced programmable function

Power management solutions

As part of a complete enterprise energy management solution, the ION7550 RTU can be integrated with EcoStruxure™ Power Monitoring Expert, or other SCADA, information and automation systems.

Conformity of standards

- | | |
|-----------------|-----------------|
| • EN 61010-1 | • IEC 61000-4-4 |
| • IEC 61000-4-2 | • IEC 61000-4-5 |
| • IEC 61000-4-3 | • CISPR 22 |

Main characteristics

- Increase efficiency
 - Reduce waste and optimise equipment operation to increase efficiency.
- Easy to operate
 - Screen-based menu system to configure meter settings. Bright LCD display with adjustable contrast.
- Integrate with software
 - Easily integrated with PowerLogic or other energy management enterprises, including SCADA systems.
- Transducer and equipment condition monitoring
 - Versatile communications, extensive I/O points, clock synchronisation, event logging and sequence of events recording capabilities for transducer and equipment condition and status monitoring at utility substations.
- Set automatic alarms
 - Alarm setpoint learning feature for optimum threshold settings.
- Up to 10 Mbytes of memory
 - For archiving of data and waveforms.
- Notify alarms via email
 - High-priority alarms sent directly to the user's PC. Instant notification of power quality events by email.
- Modbus Master functionality
 - Aggregate and store data from downstream Modbus devices using serial or Ethernet connections

ION7550 RTU

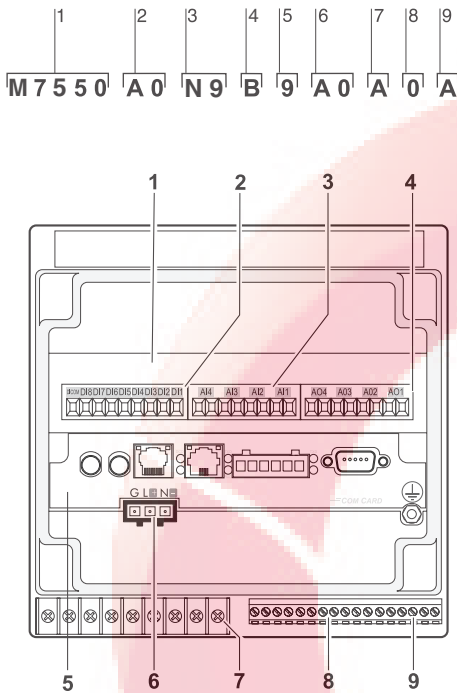

Part numbers

Item	Code	Description
1	Model	7550 ION7550 device
2	Form Factor	A0 Integrated display with front optical port, 5 MB logging memory, and 512 samples/cycle resolution.
		B0 Integrated display with front optical port, 10 MB logging memory, and 512 samples/cycle resolution.
		T0 Transducer (no display) version, with 5 MB logging memory.
		U0 Transducer (no display) version, with 10 MB logging memory.
3	RTU option	N9 RTU option
4	Power Supply	B Standard power supply (85-240 VAC, ±10%/47-63 Hz / 110-330 VDC, ±10%)
		C Low voltage DC power supply (20-60 VDC)
5	Internal use	9 This field for internal use only
6	Communications	A0 Standard communications (1 RS-232/RS-485 port, 1 RS-485 port). Integrated display models also include 1 ANSI Type 2 optical communications port.
		C1 Standard communications plus 10BASE-T/100BASE-TX Ethernet (RJ-45), 56k universal internal modem (RJ-11). Ethernet, modem gateway functions each use a serial port.
		D7 Standard comms plus 10BASE-T/100BASE-TX Ethernet (RJ-45) and 100BASE-FX Ethernet Fiber, 56k universal internal modem (RJ-11). Ethernet and modem gateway functions each use a serial communications port.
		E0 Standard communications plus 10BASE-T/100BASE-TX Ethernet (RJ-45). Ethernet gateway function uses serial port.
		F1 Standard communications plus 10BASE-T/100BASE-TX Ethernet (RJ-45) and 100BASE-FX (SC fiber optic connection). Ethernet gateway uses a serial port.
		M1 Standard communications plus 56k universal internal modem (RJ-11). Modem gateway uses serial communications port.
		A Standard I/O (8 digital inputs, 3 Form C relays, 4 Form A solid-state outputs)
7	I/O	E Standard I/O plus Expansion I/O card (8 additional digital inputs & four 0 to 20 mA analogue inputs)
		K Standard I/O plus Expansion I/O card (8 additional digital inputs & four 0 to 20 mA analogue outputs)
		N Standard I/O plus Expansion I/O card (8 additional digital inputs & four 0 to 20 mA analogue inputs and four 0 to 20 mA outputs)
		P Standard I/O plus Expansion I/O card (8 additional digital inputs & four 0 to 1 analogue inputs and four -1 to 1 mA analogue outputs)
8	Security	0 Password protected, no hardware lock
		A None
9	Special Order	A None
		C Tropicalisation treatment applied

ION7550 RTU

Commercial ref. no.	Communication Card for ION7550RTU
P765CA0A	Standard Comms: 1 RS-232/RS-485 port (COM1), 1 RS-485 port (COM2), Front optical port (COM3)
P765CA0C	Standard Comms: 1 RS-232/RS-485 port (COM1), 1 RS-485 port (COM2), Front optical port (COM3), tropicalisation treatment applied
P765CC1A	Standard plus Ethernet (10/100BASE-T), 56k universal internal modem (RJ11; shares COM3)
P765CC1C	Standard plus Ethernet (10/100BASE-T), 56k universal internal modem (RJ11; shares COM3), tropicalisation treatment applied
P765CD7A	Standard plus Ethernet (10/100BASE-T, 100BASE-FX), 56k internal modem (RJ11)
P765CD7C	Standard plus Ethernet (10/100BASE-T, 100BASE-FX), 56k internal modem (RJ11), tropicalisation treatment applied
P765CE0A	Standard plus Ethernet (10/100BASE-T)
P765CE0C	Standard plus Ethernet (10/100BASE-T), tropicalisation treatment applied
P765CF1A	Standard plus Ethernet (10/100BASE-T, 100BASE-FX)
P765CF1C	Standard plus Ethernet (10/100BASE-T, 100BASE-FX), tropicalisation treatment applied
P765CM1A	Standard plus 56k universal internal modem (RJ11; shares COM3)
P765CM1C	Standard plus 56k universal internal modem (RJ11; shares COM3), tropicalisation treatment applied
Commercial ref. no.	Analogue I/O cards
P760AEA	four 0 to 20 mA analogue inputs & 8 digital inputs
P760AEC	four 0 to 20 mA analogue inputs & 8 digital inputs, tropicalisation treatment applied
P760AKA	four 0 to 20 mA analogue outputs & 8 digital inputs
P760AKC	four 0 to 20 mA analogue outputs & 8 digital inputs, tropicalisation treatment applied
P760ANA	four 0 to 20 mA analogue inputs, four 0 to 20 mA analogue outputs & 8 digital inputs
P760ANC	four 0 to 20 mA analogue inputs, four 0 to 20 mA analogue outputs & 8 digital inputs, tropicalisation treatment applied
P760APA	four 0 to 1 analogue inputs, four -1 to 1 mA analogue outputs & 8 digital inputs.
P760APC	four 0 to 1 analogue inputs, four -1 to 1 mA analogue outputs & 8 digital inputs, tropicalisation treatment applied

optimizer

ION7550 RTU

Commercial ref. no.	OpenDAC rack, controllers, power supply
70LRCK16-48	OpenDAC rack. Holds up to 8 OpenLine modules to provide up to 16 I/O points. Requires communications controller
72-MOD-4000	OpenDAC OpenDAC RS-485 serial module. Communications controller for use in a Modbus RTU network. Supports up to 2 70LRCK16-48 OpenDAC racks
72-ETH-T000	OpenDAC Ethernet network module for use on an Modbus/TCP Ethernet network. Supports up to 2 OpenDAC racks
PS-240-15W	85-264 V AC/110-370 V DC 15 W power supply. Required for applying power to the racks and controllers
Commercial ref. no.	OpenLine digital I/O modules
70L-IAC	digital input, 120 V AC
70L-IACA	digital input, 220 V AC
70L-IDC	digital input, 3-32 V DC
70L-IDCB	digital input, fast switching
70L-IDCNP	digital input, 15-32 V AC/10-32 V DC
70L-IDC5S	dry contact closure-sensing DC input
70L-ISW	input test module
70L-OAC	digital output, 120 V AC
70L-OACL	digital output, 120 V AC inductive loads
70L-OACA	digital output, 220 V AC
70L-OACAL	digital output, 220 V AC inductive loads
70L-ODC	digital output, 3-60 V DC fast
70L-ODCA	digital output, 4-200 V DC
70L-ODCB	digital output, fast switching
70L-ODC5R	digital output, dry contact
Ordering reference	OpenLine analogue I/O modules
73L-II020	analogue input, current, 0-20 mA
73L-II420	analogue input, current, 4-20 mA
73L-ITCJ	analogue input, temperature, J-type TC
73L-ITCK	analogue input, temperature, K-type TC
73L-ITCT	analogue input, temperature, T-type TC
73L-ITR100	analogue input, temperature, RTD
73L-ITR3100	analogue input, temperature, 3wire RTD
73L-ITR4100	analogue input, temperature, 4wire RTD
73L-IV1	analogue input, voltage, 0-1 V DC
73L-IV10	analogue input, voltage, 0-10 V DC
73L-IV10B	analogue input, voltage, -10 to 10 V DC
73L-IV100M	analogue input, voltage, 0-100 V DC
73L-IV5	analogue input, voltage, 0-5 V DC
73L-IV5B	analogue input, voltage, -5 to 5 V DC
73L-IV50M	analogue input, voltage, 0-50 mV
73L-OI020	analogue output, current, 0-20 mA
73L-OI420	analogue output, current, 4-20 mA
73L-OV10	analogue output, voltage, 0-10 V DC
73L-OV10B	analogue output, voltage, -10 to 10 V DC
73L-OV5	analogue output, voltage, 0-5 V DC
73L-OV5B	analogue output, voltage, -5 to 5 V DC

ION7550 RTU

Features	
	ION7550 RTU
Data recording	
Min/max of instantaneous values	■
Data logs	■
Event logs	■
Trending	■
SER (Sequence of event recording)	■
Time stamping	■
GPS synchronisation (1 ms)	■
Memory (in Mbytes)	10
Display and I/O	
Front panel display	■
Pulse output	1
Digital or analogue inputs(max)	24
Digital or analogue outputs (max, including pulse output)	30
Communication	
RS-485 port	1
RS-485 / RS-232 port	1
Optical port	1
Modbus TCP Master / Slave (Ethernet port)	■ / ■
Modbus RTU Master / Slave (Serial port)	■ / ■
Ethernet port (Modbus/TCP/IP protocol)	1
Ethernet gateway (EtherGate)	1
Alarms (optional automatic alarm setting)	■
Alarm notification via email (Meterm@il)	■
HTML web page server (WebMeter)	■
Internal modem	1
Modem gateway (ModemGate)	■
DNP 3.0 through serial, modem, and I/R ports	■

optimizer

ION7550 RTU

Electrical characteristics		
Data update rate		1/2 cycle or 1 second
Power supply	AC	85-240 V AC $\pm 10\%$ (47-63 Hz)
	DC	110-300 V DC $\pm 10\%$
	DC low voltage (optional)	20-60 V DC $\pm 10\%$
	Ride-through time	100 ms (6 cycles at 60 Hz) min. at 120 V DC
	Burden	Standard: typical 15 VA, max 35 VA Low voltage DC: typical 12 VA, max 18 VA
Input/outputs ⁽¹⁾	Standard	8 digital inputs (120 V DC) 3 relay outputs (250 V AC / 30 V DC) 4 digital outputs (solid state)
	Optional	8 additional digital inputs 4 analogue outputs, and/or 4 analogue inputs
Mechanical characteristics		
Weight		1.9 kg
IP degree of protection (IEC 60529)		IP52
Dimensions	Standard model	192 x 192 x 159 mm
	TRAN model	235.5 x 216.3 x 133.1 mm
Environmental conditions		
Operating temperature	Standard power supply	-20 to 70°C
	Low voltage DC supply	-20 to 50°C
	Display operating range	-20 to 70°C
Storage temperature	Display, TRAN	-40 to 85°C
Humidity rating		5 to 95 % non-condensing
Installation category		III (2000 m above sea level)
Dielectric withstand		As per EN 61010-1, IEC 62051-22A ⁽²⁾
Electromagnetic compatibility		
Electrostatic discharge		IEC 61000-4-2
Immunity to radiated fields		IEC 61000-4-3
Immunity to fast transients		IEC 61000-4-4
Immunity to surges		IEC 61000-4-5
Conducted and radiated emissions		CISPR 22
Safety		
Europe		IEC 61010-1

(1) Consult the ION7550 / ION7650 installation guide for complete specifications.

(2) IEC 62051-22B with serial ports only.

optimizer

ION7550 RTU

Communication	
RS-232/RS-485 port ⁽¹⁾	Up to 115,200 bauds (57,600 bauds for RS-485), ION, DNP 3.0, Modbus, GPS, EtherGate, ModemGate, Modbus Master
RS-485 port ⁽¹⁾	Up to 115,200 bauds, ION, DNP 3.0, Modbus, GPS, EtherGate, ModemGate, Modbus Master
Infrared port ⁽¹⁾	ANSI type 2, up to 19,200 bauds, ION, Modbus, DNP 3.0
Ethernet port	10BASET, 100BASETX, RJ45 connector, 10/100 m link
Fibre-optic Ethernet link	100BASE FX, SC duplex connector, 1300 nm, FO multimode with gradient index 62.5/125 µm or 50/125 µm, 2000 m link
Protocol	ION, Modbus, Modbus Master, TCP/IP, DNP 3.0, Telnet
EtherGate	Communicates directly with up to 62 slave devices via available serial ports
ModemGate	Communicates directly with up to 31 slave devices
WebMeter	5 customisable pages, new page creation capabilities, HTML/XML compatible
Firmware characteristics	
High-speed data recording	Down to 5 ms interval burst recording, stores detailed characteristics of disturbances or outages. Trigger recording by a user-defined setpoint, or from external equipment.
Load profiling	Channel assignments (800 channels via 50 data recorders) are configurable for any measurable parameter. Trigger recorders based on time interval, calendar schedule, alarm/event condition, or manually.
Trend curves	Access historical data at the front panel. Display, trend and continuously update historical data with date and timestamps for up to four parameters simultaneously.
Alarms	Threshold alarms: adjustable pickup and dropout setpoints and time delays, numerous activation levels possible for a given type of alarm user-defined priority levels boolean combination of alarms is possible using the operators NAND, OR, NOR and XOR
Advanced security	Up to 16 users with unique access rights. Perform resets, time syncs, or meter configurations based on user privileges
Memory	5 to 10 MB (specified at time of order)
Firmware update	Update via the communication ports
Display characteristics	
Integrated display	Backlit LCD, configurable screens
Languages	English

(1) All the communication ports may be used simultaneously.

optimizer

ION7550 RTU

ION7550 RTU dimensions

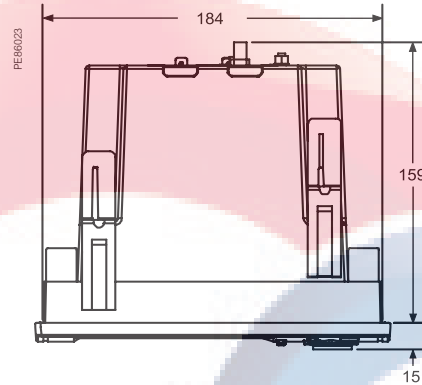
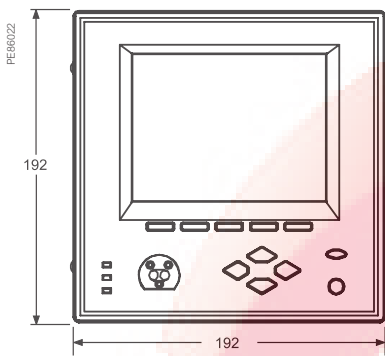

Front-panel mounting

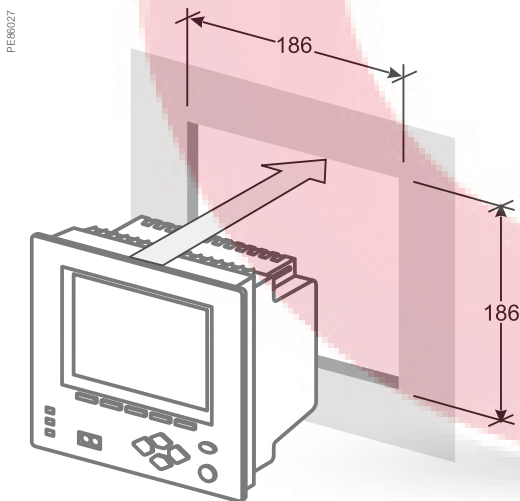

Power supply

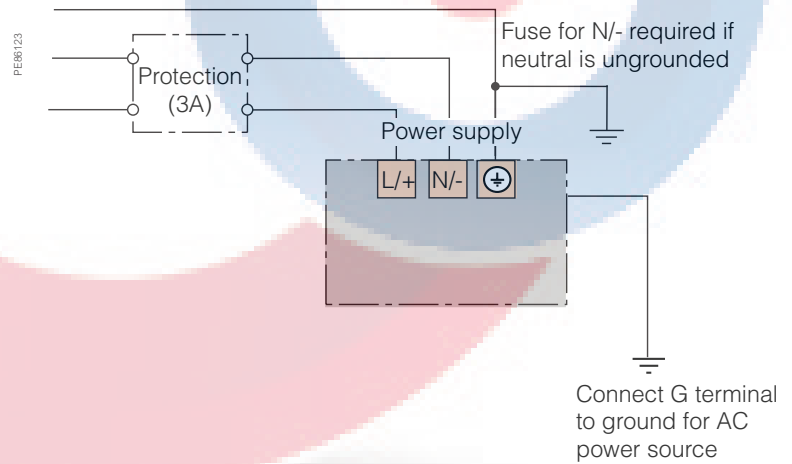

Note: the current and voltage terminal strip (I52, I51, I42, I41, I32, I31, I22, I21, I12, I11, V4, V3, V2, V1, Vref) is not present on the RTU.

optimizer

Insulation monitoring devices

An IT earthing system allows your electrical distribution system to continually operate, even in the presence of an insulation fault, without endangering people or property. Required as part of an IT earthing system, an insulation monitoring device (IMD) detects the initial fault so you can make repairs before a second fault occurs, which could trigger protective devices and halt operations.

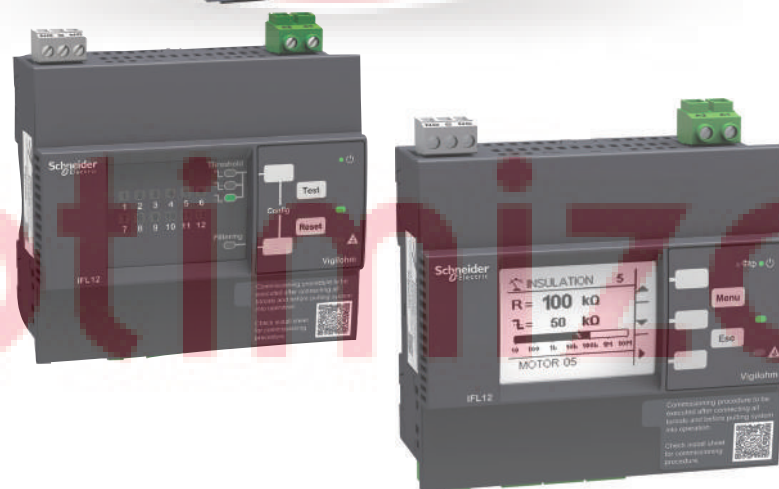
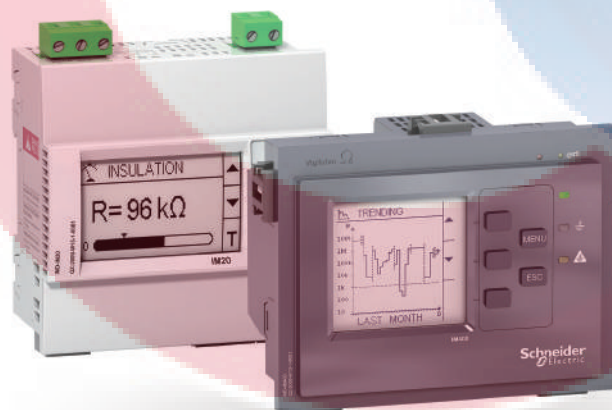

PB118026

PB118027

PB118026

Insulation Monitoring of IT / Ungrounded Networks

Unlike the TT or TN earthing systems, the neutral of the transformer is isolated from the ground for an IT earthing system (also called Ungrounded system).

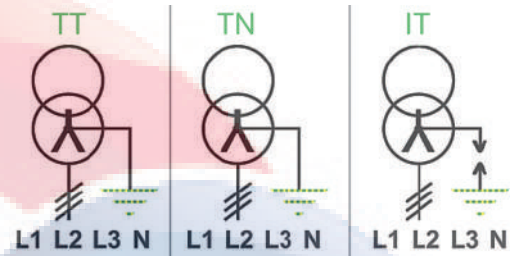

FB118029

The main interest of IT systems is that in case of one insulation fault, no trip of protective device is required as the faulty current remains low.

- Advantages of IT networks include:
- Enhanced continuity of service of the network (no trip if there is one insulation fault on the network).
- Reduced risk of electric shock.
- Reduced risk of fire or explosion (low faulty current in case of insulation fault).
- Reduced stress on the network and increased equipment life (low faulty current in case of insulation fault).

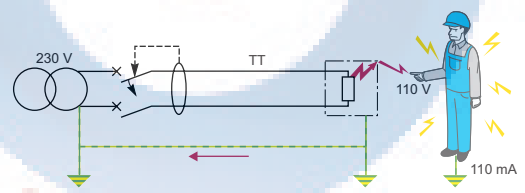

FB118030

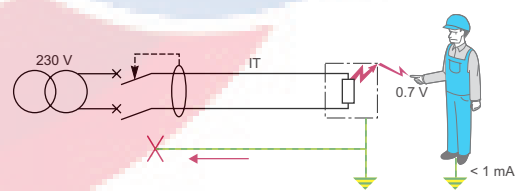

- In a situation with several insulation faults, the faulty current is no longer negligible and will cause trip of the protections.
- For this reason, Insulation Monitoring Devices are used on IT networks in order to detect a first insulation fault and indicate its location so that the fault can be repaired; hence avoiding situations with several insulation faults and maintaining the continuity of service on the network.

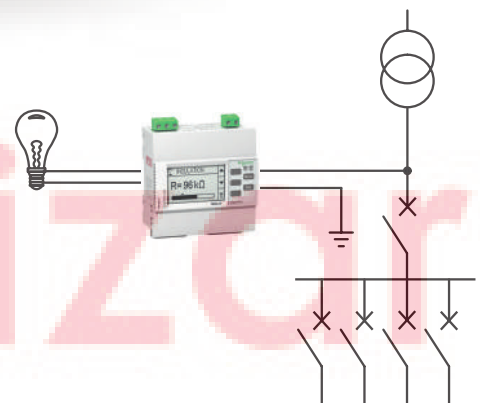

FB118031

Example of simple insulation monitoring system

Insulation Monitoring of IT / Ungrounded Networks

IT earthing systems are used for applications requiring continuity of service, such as:

- Healthcare: critical rooms in medical premises such as operating theaters, intensive care units, recovery rooms.
- Industry: critical processes in cement, steel, chemical factories, food processing, car manufacturing, water, and waste water.
- Infrastructure: control tower and take-off path in airports, lighting, and signaling networks in rail.
- Utilities: power plants and control command systems.
- Photovoltaic: solar farms.
- Marine: electrical distribution of any type of ship.
- DC applications such as electrical vehicle charging stations.

The VigiloHM catalog offers a range of products suitable for these various applications, from the simplest insulation monitoring systems to the most advanced ones, including individual insulation monitoring per feeder and communication with supervision.

Example of Healthcare network monitored by VigiloHM Insulation Monitoring Devices in compliance with IEC 60364-7-710.

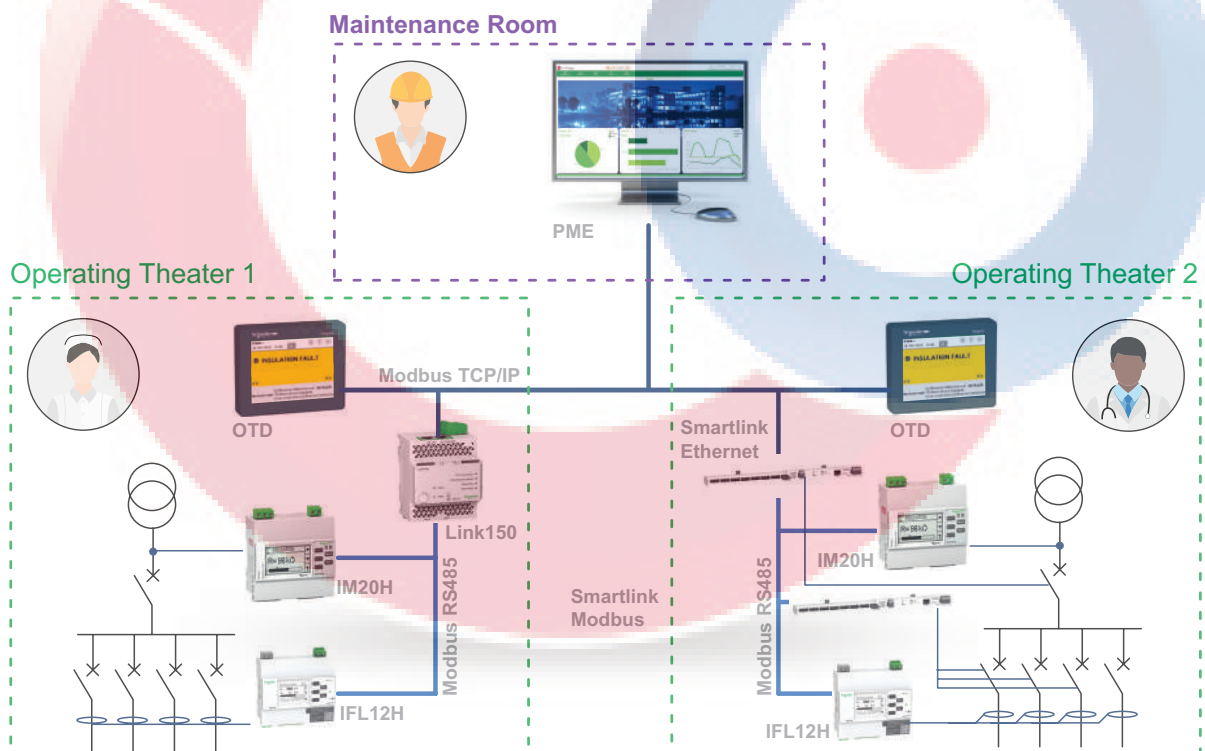

Medical staff is informed of electrical faults in the operating theater room through the local HMI (Operating Theater Display - OTD)

Technical staff is informed of any fault in the various operating theaters via a supervision system such as EcoStruxure Power Monitoring Expert.

Vigilohm Range Overview for Industrial Networks

A simple range to meet your needs
Industrial networks

Monitoring and Control
Power Monitoring & SCADA system

Communication and Simple Monitoring
Gateway, Data logger & Web Server

Insulation Monitoring Devices
Gateway, Data logger & Web Server

Insulation Fault Locators
Identification of the faulty feeder

Toroids
Used along with the Fault Locators

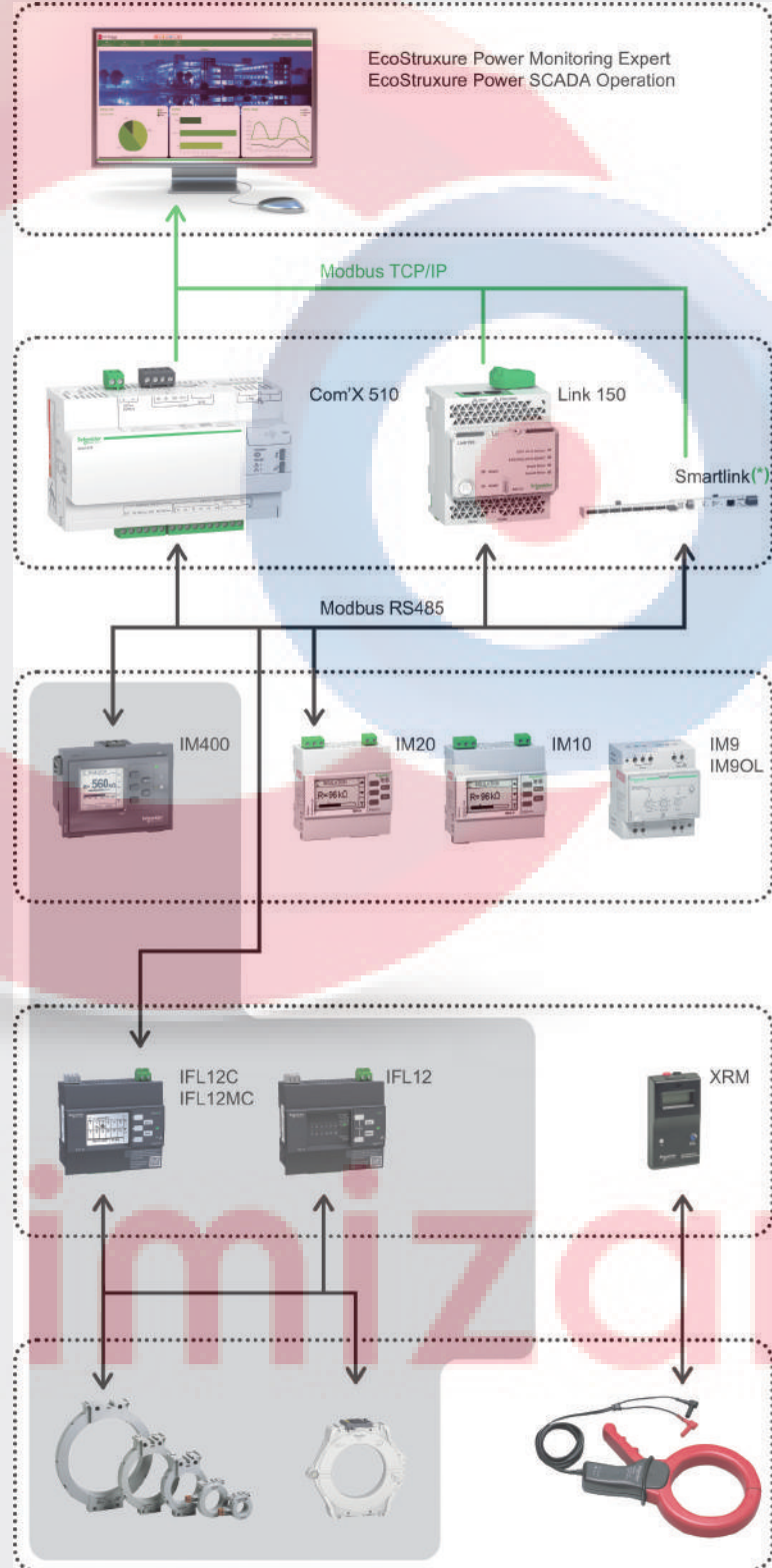

PR18033

Vigilohm Range Overview for Healthcare

PB118034

Dedicated offers for critical rooms compliant with IEC60364-7-710

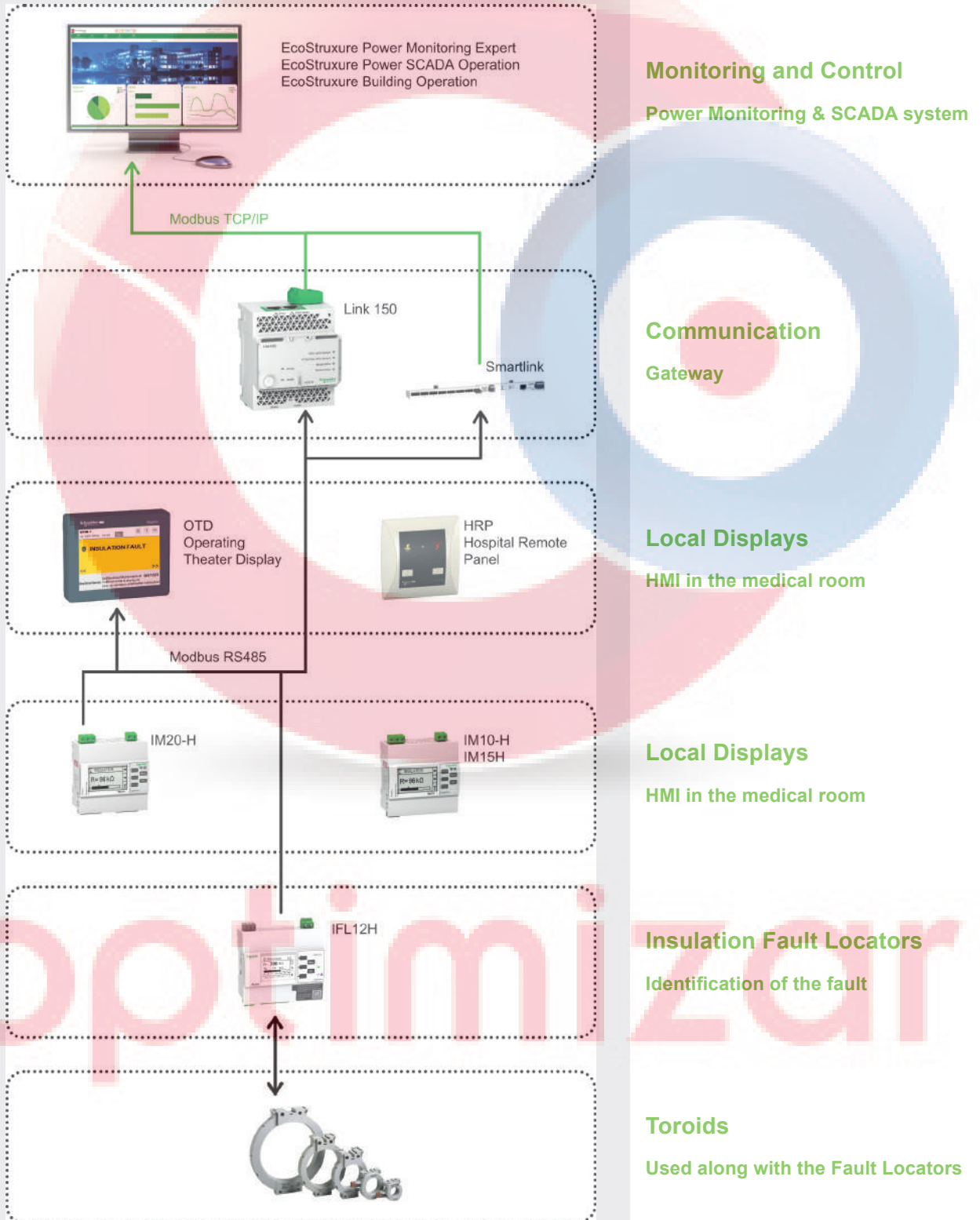

Energy & Power Management Edge Control Platforms

EcoStruxure Energy and Power management systems are especially designed to answer the needs of facilities where power is a critical resource, and where without power, lives or millions of dollars are at risk.

These systems provide facility managers with precise energy consumption data to drive energy accountability, sustainability, and savings. Your engineering manager will see power conditions at every critical point, and your maintenance personnel will use real-time status information to optimize equipment performance. And C-level executives will see the increase in productivity, profits, and ROI.

- EcoStruxure™ Power Monitoring Expert



PME



PSO

EcoStruxure™ Power Monitoring Expert

Award-winning EcoStruxure™ Power Monitoring Expert (PME) is purpose built to help power-critical and energy-intensive facilities maximize uptime and operational efficiency. As a key element of EcoStruxure Power, PME is the window to your digitized power network, taking advantage of IoT connectivity and distributed intelligence.

Applications

EcoStruxure Energy and Power Management systems provide three main elements that fit together perfectly.

Electrical Network Management

- Electrical network monitoring
- Power quality monitoring
- Electrical network alarming
- Power event analysis

Cost Management

- Energy Monitoring
- Cost allocation
- Utility bill verification
- Energy usage analysis
- Energy targetting & forecasting

Asset Management

- Breaker performance
- Capacity management
- Generator performance & compliance
- UPS performance

System architecture overview

EcoStruxure Power Monitoring Expert Natively communicates over Ethernet (IPv4 and IPv6) with a vast range of Schneider Electric devices and third-party products.

Data and analytics provided by EcoStruxure Power Monitoring Expert for centralized display, analysis, logging, alarming, event recording, and other processes can be accessed via web browser on a personal computer.

PB118039

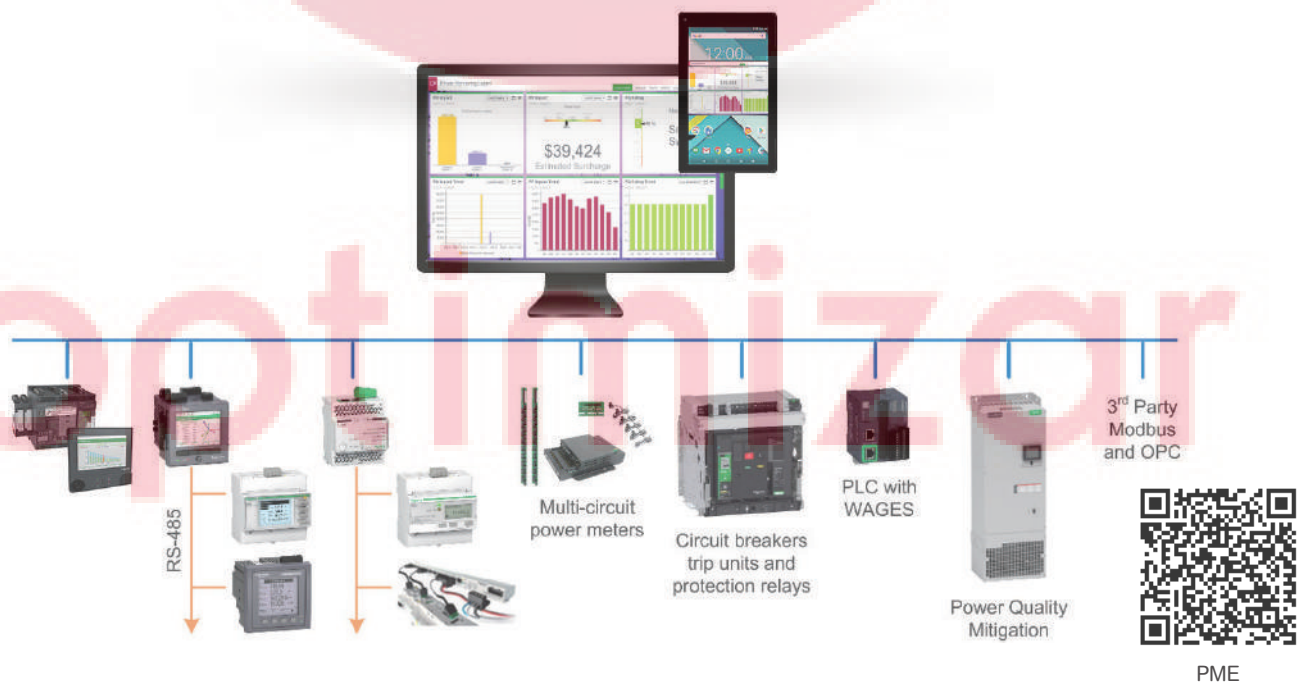

The solution for

Markets that can benefit from a solution that includes EcoStruxure™ Power Monitoring Expert:

- Healthcare
- Data Centers
- Large buildings
- Industry
- Infrastructure
- Utilities

Benefits

- Avoid outages, prevent equipment damage, optimize electrical system performance, and quickly assess power quality impacts.
- Improve energy efficiency to reduce operating cost, allocate energy cost to drive accountability and prevent unnecessary utility charges.
- Track and analyze equipment conditions, manage electrical capacity to ensure flexibility and get advanced warnings, wherever you are.

Competitive advantages

The best combination of scalability, flexibility and ease-of-use to deliver rich power and energy management applications. Including these unique and valuable features:

- Use Disturbance Direction Detection to quickly find the cause of faults.
- Power Quality KPIs help all stakeholders track progress in mitigation programs.
- Monitor breaker aging to avoid downtime due to aging equipment.
- Forecast energy expenses, validate energy efficiency investments and benchmark asset performance with modelling module.

Power management solutions

Schneider Electric provides innovative power management solutions to increase your energy efficiency and cost savings, maximize electrical network reliability and availability, and optimize electrical asset performance.

Conformity of standards

- ISO 50001/50002
- EN 50160
- IEC 61000-4-30
- IEC 62443
- IEEE 519
- ITIC/CBEMA/SEMI-F47

Cybersecurity

Complies with common IT practices (password management, whitelisting, preferred browser) and aligns with cybersecurity best practices, such as IEC 62443 SL1.



PME

EcoStruxure™ Power Monitoring Expert

Features	
Real-time Monitoring	
Diagrams	
	<ul style="list-style-type: none"> Graphical monitoring and analysis application including electrical one-line diagrams, facility maps, plan views, floor layouts, equipment representations, and mimic displays. Comprehensive out of the box set of graphical device specific diagrams showing all relevant.
Trends	
	<ul style="list-style-type: none"> Graphical charts for real-time trending of power usage (kW, Volt, Amp, and kWh) or any measurement supported by metered equipment such as generators and MV/LV switchgear.
Tables	
	<ul style="list-style-type: none"> Interactive side-by-side visualization of real-time measurements in a tabular format.
Alarm Management	
Smart Alarm Viewer	
	<ul style="list-style-type: none"> Highly customizable alarm view for sequence of events and root cause analysis. Ability to filter on multiple parameters and save customized views for easy access to critical information.
Alarm Annunciator	
	<ul style="list-style-type: none"> Alarm annunciator provides a quick summary of the active alarms in the system. Breakdown of how many of alarms are high priority, medium priority, and low priority.
Alarm Notification	
	<ul style="list-style-type: none"> Ensure that appropriate staff members are notified of power system events. The system collects data, evaluate alarm conditions, and annunciate the alarms to specified users through email or SMS text messages.
Incident Timeline Analysis Viewer	
Data Analytics & Visualization	
Dashboards	
	<ul style="list-style-type: none"> Interactive auto-updating dashboard views that may contain water, air, gas, electric, and steam (WAGES) energy summary data, historical data trends, images, and content from any accessible URL addresses. Users can create, modify, view, and share their dashboards.
Reports	
	<ul style="list-style-type: none"> Web-enabled reporting tool to view historical data in pre-formatted or user-defined report templates. The system supports reporting on all supported physical devices and virtual (or calculated) meters as defined in the device hierarchy. Users can to create, modify, view and share their reports in the web reports interface.
Calculation & Logic Engine	
	<ul style="list-style-type: none"> Graphical, object-oriented programming interface for creating system-wide, logical programs with arithmetic, data import, alarming and logging capabilities. Includes a comprehensive set of functions to create custom applications programs such as weather or real-time price import, KPI calculations, energy units conversion, data aggregation, data normalization, data comparison, power loss calculations, power factor control, load shedding, etc.
Optional Software Modules	
Electrical Network Management	
	<ul style="list-style-type: none"> Power Quality Performance Module. Power Capacity Module. Event Notification Module.
Cost Management	
	<ul style="list-style-type: none"> Energy Billing Module. Energy Analysis Module. Power Efficiency Module.
Asset Management	
	<ul style="list-style-type: none"> Breaker Performance Module. Generator Performance/EPSS Module. UPS Performances Module.

EcoStruxure™ Power Monitoring Expert

Types of supported devices

EcoStruxure Power Monitoring Expert natively supports more than 80 Schneider Electric devices, including:

Power and energy meters:

- ION9000 Series
- ION8800 Series, ION8650 Series
- ION7400, ION7650/7550, ION7550 RTU
- PM5000 Series
- PM3000 Series (PM3250, PM3255)
- PM800 Series (PM810, PM820, PM850, PM870)
- iEM2000 Series (iEM2000, iEM2000T, iEM2010, iEM2050, iEM2055, iEM2105, iEM2110, iEM2135, iEM2150, iEM2155)
- iEM3000 Series (iEM3150, iEM3155, iEM3250, iEM3255, iEM3350, iEM3355, iEM3455, iEM3555)
- EM4200 (EM4235, EM4236)
- MTZ with ML X
- PowerTag and PowerTag NSX
- Switchgear Monitoring Device (for Continuous Thermal Monitoring)

PowerLogic branch circuit power meters:

- BCPM (A, B, C models)
- EM4900
- Enersure BCPM

Circuit breaker trip units:

- Micrologic X, A, E, P and H devices
- Micrologic Compact NSX Type A and Type E
- Smartlink

Protective relays:

- Sepam Series 10, 20, 40, 60, 80

Insulation monitors:

- Vigilohm IM20/20H

In addition, a library of more than 200 third-party device drivers is available. Ask your Schneider Electric representative for details.

EcoStruxure™ Power Monitoring Expert dashboard (Hero page sample)



EcoStruxure™ Power Monitoring Expert dashboard (Energy Production sample)

Supported languages

English, Spanish, French, German, Chinese, Simplified Chinese, Polish, Czech, Italian, Swedish, Portuguese, and Russian (Other languages may be available - contact your Schneider Electric representative.)

Communication protocols and data exchange

EcoStruxure Power Monitoring Expert is designed to be easily integrated with third-party devices and systems:

- Modbus TCP and RTU
- ION Protocol
- OPC DA (Client and Server)
- SOAP based Web Services

Other data exchange technologies supported are:

- XML and CSV files
- OLEDB and ODBC
- ETL (Extract Transform Load)
- PQDIF and COMTRADE (Export only)



PME

EcoStruxure™ Power Monitoring Expert

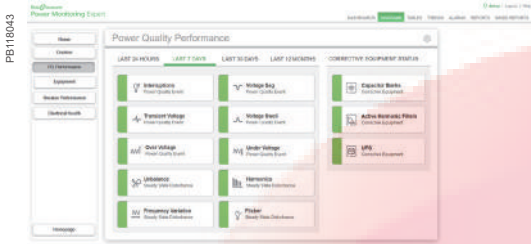

EcoStruxure™ Power Monitoring Expert dashboard (PQ Performance sample)



EcoStruxure™ Power Monitoring Expert dashboard (Trends sample)

Software compatibility

Operating systems:

- Windows 10 Professional/Enterprise
- Windows Server 2012 Standard/Enterprise
- Windows Server 2012 R2 Standard
- Windows Server 2016 Standard

SQL server:

- SQL Server 2012 Express/Standard/Enterprise/Business Intelligence, SP3
- SQL Server 2014 Express/Standard/Enterprise/Business Intelligence, SP1 SP2
- SQL Server 2016 Express/Standard/Enterprise/Business Intelligence, SP1
- SQL Server 2017 Express/Standard/Enterprise/Business Intelligence, SP1

Browsers supported:

- Microsoft Internet Explorer versions 10 and 11
- Microsoft Edge
- Google Chrome version 42 and later
- Mozilla Firefox version 35 and later
- Apple Safari versions 7 or 8 and later versions, respectively, on Mac computers

ISO 50001 Certified

EcoStruxure Power Monitoring Expert support compliance with the requirements of the standards ISO 50001 and ISO 50002.



PME

optimizer

EcoStruxure™ Power Monitoring Expert

Commercial reference numbers

Commercial ref. no.	EcoStruxure™ Power Monitoring Expert Software
Server & Options	
PSWSANCZZSPEZZ	PME Standard Edition BASE licence (includes 1 Engineering Client)
PSWSONCZZSPEZZ	OPC DA Server for PME software
PSWSQL2016L	SQL Server Standard Edition Licence - 2 Core pack
PSWMVNCZZSPEZZ	Event Notification modul for PME software
Client Licences (System users)	
PSWCENCZZNPEZZ	Engineering Client for Power Monitoring Expert software
PSWCWNCZZNPEZZ	Web Client for PME software
PSWCZNCZZSPEZZ	Unlimited Engineering and Web Clients for PME software
Device Licences (Connected devices)	
PSWDENCZZNPEZZ	Entry-Range Device for PME software
PSWDMNCZZNPEZZ	Mid-Range Device for PME software
PSWDSNCZZNPEZZ	High-End Device for PME software
PSWDZNCZZSPEZZ	Unlimited Devices for PME software
Device Licences (Connected devices) US, India, & Canada	
PSWDANCZZNPEZZ	5 Device Pack for PME software
PSWDBNCZZNPEZZ	25 Device Pack for PME software
PSWDCNCZZNPEZZ	50 Device Pack for PME software
PSWDDNCZZNPEZZ	100 Device Pack for PME software
PSWDFNCZZNPEZZ	200 Device Pack for PME software
PSWDZNCZZSPEZZ	Unlimited Device Pack for PME software
Optional Software Modules	
PSWMBNCZZSPEZZ	Billing Module for PME software
PSWMXNCZZSPEZZ	Breaker Performance Module for PME software
PSWMZNCZZSPEZZ	Energy Analysis Module for PME software
PSWMENCZZSPEZZ	EPSS Module for PME software
PSWMPNPAZSPEZZ	Generator Performance Module PME software
PSWMNNPAZSPEZZ	IT Billing Module for PME software
PSWMPNCZZSPEZZ	Power Capacity Module for PME software
PSWMNNCZZSPEZZ	Power Efficiency Module for PME software
PSWMUNCZZSPEZZ	UPS Performance Module for PME software

Contact your Schneider Electric representative for complete ordering information.



PME

optimizer

EcoStruxure™ Power SCADA Operation

The power of a SCADA uniquely designed for critical power management.

Perfect for even the most demanding facility. Its intuitive, interactive, and customizable interface provides practical information: detailed alarming, real-time monitoring and control, and power-related visualization tools. It integrates seamlessly with your electrical systems and easily scales to evolve with your needs.

Applications

An excellent fit for virtually every industry and application, EcoStruxure™ Power SCADA Operation delivers exceptional scalability so that it can grow to meet your multiple, changing business requirements while driving down the total cost of ownership.

Key Applications delivered using Power SCADA + Advanced Reporting

SAFE Protect People & Assets	RELIABLE Optimize Business Continuity	EFFICIENT Maximize Operational & Deployment Efficiency	COMPLIANT Simplify Regulatory Compliance
Thermal Monitoring	Electrical Distribution Monitoring & Alarming	Commissioning Productivity	Energy Efficiency Compliance
	Power Event Analysis	Energy Performance Analysis	Power Quality Compliance
	Power Quality Monitoring	Energy Usage Analysis	Backup Power Compliance (HC)
	Source / Network Control	Utility Bill Verification	Cyber Security

PB118048



PSO

The solution for

Markets that can benefit from a solution that includes EcoStruxure™ Power SCADA Operation:

- Healthcare
- Data Centers
- Large Buildings
- Industry
- Infrastructure
- Utilities

Benefits

- Maximize power availability via real-time monitoring and control of critical loads.
- Maximize availability of edge control platform via native software redundancy capabilities.
- Extensive communication and data exchange protocols providing an open platform to connect with a wide variety of third-party devices.
- Highly flexible platform offering customized end-user screens and experience.

Competitive advantages

- Designed for power systems providing a lower total cost of ownership versus process automation SCADA systems.
- High performance alarming and mobile notification to manage your complex power system.
- Reporting and dashboards module with comprehensive energy and power templates to deliver powerful analytics.
- Capability to perform sequence of events analysis for power systems using real-time stamp data and electrical waveforms captured directly from connected electrical devices.

Power management solutions

Schneider Electric provides innovative power management solutions to increase your energy efficiency and cost savings, maximize electrical network reliability and availability, and optimize electrical asset performance.

Conformity of standards

- ISO 50001
- IEC 62443

Conformity of standards when using Advanced Reporting and Dashboards

- EN 50160
- IEC 61000-4-30
- IEEE 519
- ITIC/CBEMA

Cybersecurity technology highlights

- IEC 62443
- Robust user management
- Password policies
- Auto logoff timers
- Multi-factor authentication
- Role-based access control (RBAC)
- Object level security
- Active Directory integration
- Audit logs
- Application Whitelisting

optimizer



PSO

EcoStruxure™ Power SCADA Operation



EcoStruxure™ Power SCADA Operation dashboard

EcoStruxure™ Power SCADA Operation is a reliable, flexible and high performance monitoring and control solution designed to reduce outages and increase power efficiency. It is built to handle user requirements from the smallest to the most demanding enterprises, while still providing high time performance and reliability. Easy-to-use configuration tools and powerful features enable faster development and deployment of any size of application.

Object-based, standard graphics and symbols provide operators with an interactive and user-friendly interface. Intuitive commands and controls increase efficiency of operators to interact with the system interface. EcoStruxure™ Power SCADA Operation controls your system with high reliability, performance and data integrity through the use of advanced architectures, such as hot/warm redundant I/O device configurations, self-healing ring communications, and primary and standby server configurations. Comprehensive user-based security is integrated into all interface elements, ensuring a cyber resilient control system.

- Typical applications

- EcoStruxure™ Power SCADA Operation software has the following applications:
 1. Power Monitoring and Control - Notify in real time when deviations from normal operating conditions occur and control electrical equipment safely and reliably in response to these conditions.
 2. Power Availability – Improve continuity of electrical system by identifying root causes of problems to quickly recover power and avoid future outages.
 3. Energy Monitoring – Establish baseline energy usage, set reduction targets, adjust operations for continuous improvements.

- System architecture

- Human machine interface (HMI)
 - EcoStruxure™ Power SCADA Operation offers secure, operator-dedicated, multi-user data and control access through a local server interface, full control client and also through web clients.

- Main components

- SCADA software
 - Drivers, libraries and communication tools.
 - Use these components to configure your SCADA network, including communication paths, devices and logical groups.

- Functional components of EcoStruxure™ Power SCADA Operation

- Includes gateways, PLCs, RTUs, switches, etc.
- Redundant, self-healing ring, double-ring technology.
- Design reference guide.
- Design of architectures to achieve time performance & reliability.
- Schneider Services.
 - Pro-active assistance to facility maintenance team for sensitive electrical distribution maintenance operations.

- Data acquisition and management

- Redundant I/O server
- Hot/warm standby: data acquisition is never interrupted even if one server fails.
- Distributed, multiple server architecture with corresponding configuration tools.
- IEC61850 compliant databases.
- Designed for interoperable exchange of data for distributed substation automation systems and third-party devices.
- Supports data import/export with compliant devices and systems.



Waveform viewer dashboard (sample)

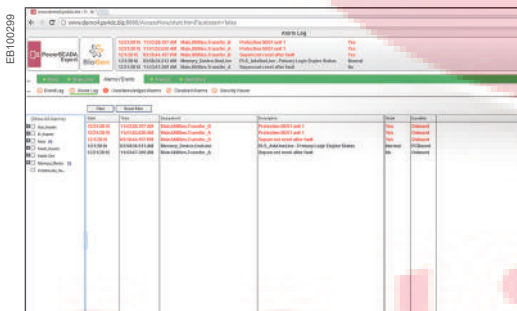

Alarm Viewer (sample)



PSO

EcoStruxure™ Power SCADA Operation

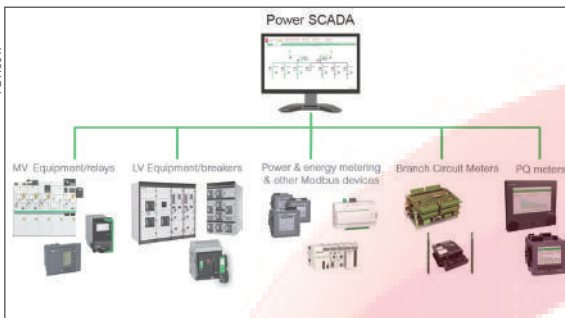

Typical EcoStruxure™ Power SCADA Operation architecture

- Data acquisition and integration
 - Integrate electrical distribution devices with PLCs, RTUs, Controllers and other intelligent energy devices. Native, out-of-the-box support for all Sepam Series 20, 40, 80, and Sepam 2000 (S36), PowerPact, Compact NSX, Masterpact NT/NW, Masterpact MTZ with communicating Micrologic Trip/Base Units,
 - ION7650, PM8000, PM5000 series and BCPM . Enables access to meter data, digital outputs and remote configuration. Interface with PLCs, RTUs and power distribution equipment. Quickly add and configure devices with easy-to-use I/O Device Wizard and Profile Editor. Scalable platform enables remote devices and user clients to be added as needs grow while maintaining your original investment. Integrate with other energy management or automation systems through Modbus TCP/IP.
- Alarms and events
 - EcoStruxure™ Power SCADA Operation software allows you to receive alerts to outages or impending problems that could lead to equipment stress, failures, or downtime. Configure alarms to trigger on events, power thresholds, or equipment conditions. The software logs complete information on an event, including related coincident conditions, all with accurate 1ms timestamping.
 - Eight different alarm levels with customized colouring and customized audible sounds to easily segregate alarms.
 - High speed alarm response. Capture and log every single alarm or event.
 - Organise, filter and print by any alarm property, such as time, severity, equipment, state, priority, etc. Configure specific alarm occurrences to change symbol color or flash an icon on a page.
 - View the five most recent alarms from every page, providing detailed information in easy-to-understand formats.
 - Event log for all PC-based and on-board field events, alarms.
 - Easily configure to annunciate based on alarm type.
- Standards supported
 - IEC 61850 (Edition 1 and 2)
 - DNP3
 - ION
 - Modbus
 - IEC 60870-5-104
 - BACnet/IP
 - SNMP
- Electrical distribution control
 - Perform fast, manual control operations by clicking on-screen buttons to operate remote breakers, protection relays, and other power distribution equipment.
- Real-time monitoring
 - View all distribution points across your network. Secure display of real-time power and energy measurements, historical trends and data logs, alarm conditions, equipment status (on/off, temperature, pressure, etc.), control triggers, and analysis tools.
 - One line diagrams with real-time monitoring and control of devices, objects and distribution points. Point-and-click navigation reveals deeper layers of detail.
 - IEC and ANSI-standard symbols and templates that are fully animated and interactive, to blend control and display functionality.
 - Dynamic colouring is easily configured using the default set or user-defined colours and voltage levels.
 - True color, easy-to-use human machine interface (HMI) that provides operators with intuitive and consistent screens



PSO

EcoStruxure™ Power SCADA Operation

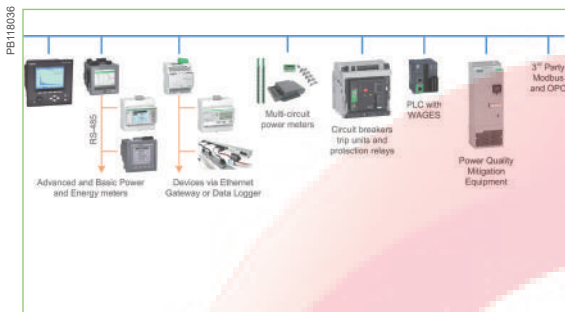

Power SCADA Operation sample Trends display

- Analysis

- Trend and analyse on any measured parameter, allowing operators to recognise patterns that may lead to disturbances. Display millisecond-accurate historical alarms and trends to help determine the sequence of events or root cause analysis. Unite trend and alarm data for sophisticated disturbance views and analysis.

User-defined colour coding and overlays clearly highlight data series, time ranges, thresholds and limits. View COMTRADE waveforms, record, save or export trends to archives. Supported protocols include: Schneider Electric devices with WFC capabilities via Modbus and ION and 3rd party devices via IEC-61850 with compliant COMTRADE WFC capabilities.

- Configuration tools

- EcoStruxure™ Power SCADA Operation is supplied with a package of configuration tools designed to make set up uniquely easy and quick.
- Designed to help make project set up and network configuration fast and easy.
- Profile Editor provides standard device types and their associated profiles and allows engineers to easily customise the profiles of the devices specific to the project. New export/import capability allows easier sharing of profiles.
- Standardized tags per device profile (configurable), XML file
 - Creates, adds, edits device types, tags and profiles.
- I/O Device Manager provides a standard interface for quick SCADA data base generation:
 - Instantiation of devices, on a per object basis.
- Creates tags, trends, alarms and events when devices are added to system.
 - Batch editing supported by automation interface.

- Minimum system requirements

(Consult your local Schneider Electric representative for complete system requirements and commissioning information for EcoStruxure™ Power SCADA Operation). The following are minimum support requirements with factory default settings.

- Runs on standard PCs or servers, and supports the following operating systems: Windows Server 2016, Windows 10, Windows Server 2012 R2, Windows 8.1, Windows Server 2012, Windows 8, Windows 2008 R2 and Windows 7

- Open data exchange protocol support

- OPC UA 1.01 client
- OPC DA 2.0 server and client
- OPC AE 1.0 server

optimizer



PSO

EcoStruxure™ Power SCADA Expert

Commercial reference numbers

Commercial ref. no.	EcoStruxure™ Power SCADA Expert Software
Server Licences	
PSA101112	Power SCADA Server, 500 Points
PSA101113	Power SCADA Server, 1500 Points
PSA101114	Power SCADA Server, 5000 Points
PSA101115	Power SCADA Server, 15000 Points
PSA101199	Power SCADA Server, Unlimited Points
Control Clients	
PSA102012	Power SCADA Control Client, 500 Points
PSA102013	Power SCADA Control Client, 1500 Points
PSA102014	Power SCADA Control Client, 5000 Points
PSA102015	Power SCADA Control Client, 15000 Points
PSA102099	Power SCADA Control Client, Unlimited Points
PSA102099P5	Power SCADA Control Client, Unlimited Points, 5 Pack
PSA102099P10	Power SCADA Control Client, Unlimited Points, 10 Pack
PSA102099P25	Power SCADA Control Client, Unlimited Points, 25 Pack
PSA102088	Power SCADA Control Client, Redundant licence
Device Licences (Connected devices)	
PSWDENCZZNPEZZ	Entry-Range Device for PME software
PSWDMNCZZNPEZZ	Mid-Range Device for PME software
PSWDSNCZZNPEZZ	High-End Device for PME software
PSWDZNCZZSPEZZ	Unlimited Devices for PME software
View-only Clients	
PSA103099	Power SCADA View-only Client, Unlimited Points
PSA103088	Power SCADA View-only Client, Redundant licence
HTML5 Client Licensing	
PSA105100	Power SCADA Anywhere, 5 User Pack
Modules (Advanced Reporting, Software Modules and ENM)	
PSA104112	Advanced Reporting and Dashboards Module
PSA104113	Event Notification Module
PSA104114	Energy Billing Module
PSA104115	Breaker Performance Module
PSA104116	Energy Analysis Reports Module
PSA104121	Capacity Management Module
PSA104124	Power Quality Performance Module
PSA104125	Insulation Monitoring Module
PSA104126	Backup Power Module
PSA104127	Energy Analysis Dashboards Module
CyberSecurity	
PSA200100	McAfee Whitelisting (Embedded Control)
Internal Schneider Electric Licences (For internal and EcoXpert use only, not available to customers)	
PSA109502	Power SCADA Development Licence

Contact your Schneider Electric representative for complete ordering information.

PowerLogic Commercial Reference Numbers

Commercial ref. no.	Description	Page	Commercial ref. no.	Description	Page
	Current Transformers	15	METSECT5DE100	CT tropicalised 1000 5 dual out. bars 54x102	
	CT Ip/5 A ratio	16	METSECT5DE125	CT tropicalised 1250 5 dual out. bars 54x102	
16550	44 x 66 x 37 Adapter for DIN rails Mounting plate		METSECT5DE150	CT tropicalised 1500 5 dual out. bars 54x102	
16551	56 x 84 x 60 Adapter for DIN rails Mounting plate, insulated locking screw		METSECT5DE200	CT tropicalised 2000 5 dual out. bars 54x102	
16552	56 x 84 x 60 Adapter for DIN rails Mounting plate Insulated locking screw sealable cover		METSECT5DH125	CT tropicalised 1250 5 dual out. bars 38x102	
16553	77 x 107 x 64 Adapter for DIN rails Mounting plate Insulated locking screw		METSECT5DH150	CT tropicalised 1500 5 dual out. bars 38x102	
METSECT5CC004	CC 40 A		METSECT5DH200	CT tropicalised 2000 5 dual out. bars 38x102	
METSECT5CC005	CC 50 A			Rogowski CTs	31
METSECT5CC006	CC 60 A		METSECTR30500	Rogowski CT, 250 mm core length, 96 mm dia.	
METSECT5CC008	CC 75 A		METSECTR46500	Rogowski CT, 250 mm core length, 146 mm dia.	
METSECT5CC010	CC 100 A		METSECTR60500	Rogowski CT, 250 mm core length, 191 mm dia.	
METSECT5CC013	CC 125 A		METSECTR90500	Rogowski CT, 250 mm core length, 287 mm dia.	
METSECT5CC015	CC 150 A			0.333 V 3-in-1 CTs with RJ45 for PM53xR	
METSECT5CC020	CC 200 A		METSECTV25006	LVCT SolidC 3in1 RJ45 25mmCtr 60A:1/3V	
METSECT5CC025	CC 250 A		METSECTV25010	LVCT SolidC 3in1 RJ45 25mmCtr 100A:1/3V	
METSECT5MB025	MB 250 A		METSECTV25013	LVCT SolidC 3in1 RJ45 25mmCtr 125A:1/3V	
METSECT5MB030	MB 300 A		METSECTV25016	LVCT SolidC 3in1 RJ45 25mmCtr 160A:1/3V	
METSECT5MB040	MB 400 A		METSECTV35006	LVCT SolidC 3in1 RJ45 35mmCtr 60A:1/3V	
METSECT5MA015	MA 150 A		METSECTV35010	LVCT SolidC 3in1 RJ45 35mmCtr 100A:1/3V	
METSECT5MA020	MA 200 A		METSECTV35012	LVCT SolidC 3in1 RJ45 35mmCtr 120A:1/3V	
METSECT5MA025	MA 250 A		METSECTV35013	LVCT SolidC 3in1 RJ45 35mmCtr 125A:1/3V	
METSECT5MA030	MA 300 A		METSECTV35015	LVCT SolidC 3in1 RJ45 35mmCtr 150A:1/3V	
METSECT5MA040	MA 400 A		METSECTV35016	LVCT SolidC 3in1 RJ45 35mmCtr 160A:1/3V	
METSECT5MC025	MC 250 A		METSECTV35020	LVCT SolidC 3in1 RJ45 35mmCtr 200A:1/3V	
METSECT5MC030	MC 300 A		METSECTV35025	LVCT SolidC 3in1 RJ45 35mmCtr 250A:1/3V	
METSECT5MC040	MC 400 A		METSECTV45025	LVCT SolidC 3in1 RJ45 45mmCtr 250A:1/3V	
METSECT5MC050	MC 500 A		METSECTV45030	LVCT SolidC 3in1 RJ45 45mmCtr 300A:1/3V	
METSECT5MC060	MC 600 A		METSECTV45040	LVCT SolidC 3in1 RJ45 45mmCtr 400A:1/3V	
METSECT5MC080	MC 800 A		METSECTV45050	LVCT SolidC 3in1 RJ45 45mmCtr 500A:1/3V	
METSECT5MD050	MD 500 A		METSECTV45060	LVCT SolidC 3in1 RJ45 45mmCtr 600A:1/3V	
METSECT5MD060	MD 600 A		METSECTV45063	LVCT SolidC 3in1 RJ45 45mmCtr 630A:1/3V	
METSECT5MD080	MD 800 A		METSECTV29006	LVCT SolidC 3in1 RJ45 29mmCtr 60A:1/3V	
METSECT5CYL1	Cylinder 8.5 mm dia.		METSECTV29010	LVCT SolidC 3in1 RJ45 29mmCtr 100A:1/3V	
METSECT5CYL2	Cylinder 10.5 mm dia.		METSECTV29012	LVCT SolidC 3in1 RJ45 29mmCtr 120A:1/3V	
METSECT5COVER	sealable cover 60.5 x 22 x 23.5 mm for CT TI		METSECTV29013	LVCT SolidC 3in1 RJ45 29mmCtr 125A:1/3V	
METSECT5VV500	CT tropicalised 5000 5 bars 55x165		METSECTV29015	LVCT SolidC 3in1 RJ45 29mmCtr 150A:1/3V	
METSECT5VV600	CT tropicalised 6000 5 bars 55x165		METSECTV29016	LVCT SolidC 3in1 RJ45 29mmCtr 160A:1/3V	
METSECT5DA040	CT tropicalised 400 5 dual out. bars 32x65		METSECTV29020	LVCT SolidC 3in1 RJ45 29mmCtr 200A:1/3V	
METSECT5DA050	CT tropicalised 500 5 dual out. bars 32x65		METSECTV70080	LVCT SolidC 3in1 RJ45 70mmCtr 800A:1/3V	
METSECT5DA060	CT tropicalised 600 5 dual out. bars 32x65		METSECTV70100	LVCT SolidC 3in1 RJ45 70mmCtr 1000A:1/3V	
METSECT5DA080	CT tropicalised 800 5 dual out. bars 32x65		METSECTV70125	LVCT SolidC 3in1 RJ45 70mmCtr 1250A:1/3V	
METSECT5DA100	CT tropicalised 1000 5 dual out. bars 32x65			Panel Instruments	32
METSECT5DA125	CT tropicalised 1250 5 dual out. bars 32x65			DIN rail analog ammeters, voltmeters	33
METSECT5DA150	CT tropicalised 1500 5 dual out. bars 32x65		16029	0-30 A no 8	
METSECT5DB100	CT tropicalised 1000 5 dual out. bars 38x127		16030	X/5 8	
METSECT5DB125	CT tropicalised 1250 5 dual out. bars 38x127		16031	0-5 A	
METSECT5DB150	CT tropicalised 1500 5 dual out. bars 38x127		16032	0-50 A 50/5	
METSECT5DB200	CT tropicalised 2000 5 dual out. bars 38x127		16033	0-75 A 75/5	
METSECT5DB250	CT tropicalised 2500 5 dual out. bars 38x127		16034	0-100 A 100/5	
METSECT5DB300	CT tropicalised 3000 5 dual out. bars 38x127		16035	0-150 A 150/5	
METSECT5DC200	CT tropicalised 2000 5 dual out. bars 52x127		16036	0-200 A 200/5	
METSECT5DC250	CT tropicalised 2500 5 dual out. bars 52x127		16037	0-250 A 250/5	
METSECT5DC300	CT tropicalised 3000 5 dual out. bars 52x127		16038	0-300 A 300/5	
METSECT5DC400	CT tropicalised 4000 5 dual out. bars 52x127		16039	0-400 A 400/5	
METSECT5DD100	CT tropicalised 1000 5 dual out. bars 34x84				
METSECT5DD125	CT tropicalised 1250 5 dual out. bars 34x84				
METSECT5DD150	CT tropicalised 1500 5 dual out. bars 34x84				

PowerLogic Commercial Reference Numbers

Commercial ref. no.	Description	Page	Commercial ref. no.	Description	Page
16040	0-500 A 500/5			iCI impulse counter	
16041	0-600 A 600/5		15443	iCI 4mm impulse counter DIN	
16042	0-800 A 800/5			Basic Energy Metering	43
16043	0-1000 A 1000/5			iEM2000	44
16044	0-1500 A 1500/5		A9MEM2000T	iEM2000T basic energy meter, no display	
16045	0-2000 A 2000/5		A9MEM2000	iEM2000 basic energy meter	
16060	0-300 V 8		A9MEM2010	iEM2010 energy meter, kWh pulse output	
16061	0-500 V 8		A9MEM2100	iEM2100 basic energy meter	
	DIN rail digital ammeters, voltmeter, freq meter	34	A9MEM2050	iEM2050 modular single phase power meter 230 V - 45 A with Modbus	
15202	Direct reading iAMP 0-10 A No 4		A9MEM2055	iEM2055 modular single phase power meter 230 V - 45 A with Modbus, MID	
15209	Multi-rating iAMP 0-5000 A As per rating 4		A9MEM2105	iEM2105 energy meter, kWh pulse output with partial meter	
15201	iVLT 0-600 V 4		A9MEM2110	iEM2110 energy meter, kWh and kvarh pulse outputs with two tariffs, four quadrant energy measurement, MID certified	
15208	iFRE 20-100 Hz 4		A9MEM2135	iEM2135 energy meter, M-Bus communication, four quadrant energy measurement, two tariffs, MID certified	
	72x72 analog ammeter, voltmeter	35	A9MEM2150	iEM2150 energy meter, Modbus communication, four quadrant energy measurement	
16003	AMP for motor feeder		A9MEM2155	iEM2155 energy meter, Modbus communication, four quadrant energy measurement, two tariffs, MID certified	
16004	AMP for standard feeder X/5			iEM3000	51
16009	AMP for standard feeder 0-50 A 50/5		A9MEM3100	iEM3100 basic energy meter	
16010	AMP for standard feeder 0-100 A 100/5		A9MEM3110	iEM3110 energy meter with pulse output	
16011	AMP for standard feeder 0-200 A 200/5		A9MEM3115	iEM3115 multi-tariff energy meter	
16012	AMP for standard feeder 0-400 A 400/5		A9MEM3135	iEM3135 advanced multi-tariff energy meter & electrical parameter plus M-Bus comm port	
16013	AMP for standard feeder 0-600 A 600/5		A9MEM3150	iEM3150 energy meter & electrical parameter plus Modbus RS-485 comm port	
16014	AMP for standard feeder 0-1000 A 1000/5		A9MEM3155	iEM3155 advanced multi-tariff energy meter & electrical parameter plus Modbus RS-485 comm port	
16015	AMP for standard feeder 0-1250 A 1250/5		A9MEM3165	iEM3165 advanced multi-tariff energy meter & electrical parameter plus BACnet MS/TP comm port	
16016	AMP for standard feeder 0-1500 A 1500/5		A9MEM3175	iEM3175 advanced multi-tariff energy meter & electrical parameter plus LON TP/FT-10 comm port	
16019	AMP for standard feeder 0-2000 A 2000/5		A9MEM3200	iEM3200 basic energy meter	
16003	AMP for motor feeder X/5		A9MEM3210	iEM3210 energy meter with pulse output	
16006	AMP for motor feeder 0-30-90 A 30/5		A9MEM3215	iEM3215 multi-tariff energy meter	
16007	AMP for motor feeder 0-75-225 A 75/5		A9MEM3235	iEM3235 advanced multi-tariff energy meter & electrical parameter plus M-Bus comm port	
16008	AMP for motor feeder 0-200-600 A 200/5		A9MEM3250	iEM3250 energy meter & electrical parameter plus Modbus RS-485 comm port	
16005	VLT 0-500 V		A9MEM3255	iEM3255 advanced multi-tariff energy meter & electrical parameter plus Modbus RS485 comm port	
	96x96 analog ammeter, voltmeter	36	A9MEM3265	iEM3265 advanced multi-tariff energy meter & electrical parameter plus BACnet MS/TP comm port	
16074	AMP for standard feeder X/5		A9MEM3275	iEM3275 advanced multi-tariff energy meter & electrical parameter plus LON TP/FT-10 comm port	
16079	AMP for standard feeder 0-50 A 50/5		A9MEM3300	iEM3300 basic energy meter	
16080	AMP for standard feeder 0-100 A 100/5		A9MEM3310	iEM3310 energy meter with pulse output	
16081	AMP for standard feeder 0-200 A 200/5		A9MEM3335	iEM3335 advanced multi-tariff energy meter & electrical parameter plus M-Bus comm port	
16082	AMP for standard feeder 0-400 A 400/5		A9MEM3350	iEM3350 energy meter & electrical parameter plus Modbus RS-485 comm port	
16083	AMP for standard feeder 0-600 A 600/5		A9MEM3355	iEM3355 advanced multi-tariff energy meter & electrical parameter plus Modbus RS485 comm port	
16084	AMP for standard feeder 0-1000 A 1000/5				
16085	AMP for standard feeder 0-1250 A 1250/5				
16086	AMP for standard feeder 0-1500 A 1500/5				
16087	AMP for standard feeder 0-2000 A 2000/5				
16088	AMP for standard feeder 0-2500 A 2500/5				
16089	AMP for standard feeder 0-3000 A 3000/5				
16090	AMP for standard feeder 0-4000 A 4000/5				
16091	AMP for standard feeder 0-5000 A 5000/5				
16092	AMP for standard feeder 0-6000 A 6000/5				
16073	AMP for motor feeder X/5				
16076	AMP for motor feeder 0-30-90 A 30/5				
16077	AMP for motor feeder 0-75-225 A 75/5				
16078	AMP for motor feeder 0-200-600 A 200/5				
16075	VLT 0-500 V				
	48x48 CMA, CMV selector switches	37			
16017	CMA 20 4				
16018	CMV 500 7				
	DIN rail iCMA, iCMV selector switches	38			
15126	iCMA 10 415 4				
15125	iCMV 10 415 4				
	iCH hour counter	39			
15440	iCH "DIN" 230 V AC ± 10 %/50 Hz 4mm				
15607	CH "48 x 48" 24 V AC ± 10 %/50 Hz				
15608	CH "48 x 48" 230 V AC ± 10 %/50 Hz				
15609	CH "48 x 48" 12 to 36 V DC				

PowerLogic Commercial Reference Numbers

Commercial ref. no.	Description	Page	Commercial ref. no.	Description	Page
A9MEM3365	iEM3365 advanced multi-tariff energy meter & electrical parameter plus BACnet MS/TP comm port		METSEPM5330	Power Meter range 72 mm depth, control power to 415 V AC, CI 0.5S, 31st harmonic, 256 kB, RS-485 Modbus, 2DI/2DO, 2Relay	
A9MEM3375	iEM3375 advanced multi-tariff energy meter & electrical parameter plus LON TP/FT-10 comm port		METSEPM5331	Power Meter range 72 mm depth, control power to 415 V AC, CI 0.5S, 31st harmonic, 256 kB, RS-485 Modbus, 2DI/2DO, 2Relay, MID cert	
A9MEM3455	iEM3455 advanced multi-tariff energy meter & electrical parameter plus Modbus RS-485 comm port		METSEPM5340	Power Meter range 72 mm depth, control power to 415 V AC, CI 0.5S, 31st harmonic, 256 kB, Ethernet, 2DI/2DO, 2Relay	
A9MEM3465	iEM3465 advanced multi-tariff energy meter & electrical parameter plus BACnet MS/TP comm port		METSEPM5341	Power Meter range 72 mm depth, control power to 415 V AC, CI 0.5S, 31st harmonic, 256 kB, Ethernet, 2DI/2DO, 2Relay, MID cert	
A9MEM3555	iEM3555 advanced multi-tariff energy meter & electrical parameter plus Modbus RS-485 comm port		METSEPM5560	Power Meter range 77 mm depth, control power to 480 V AC, CI 0.2S, 63rd harmonic, 1.1 MB, Modbus and Ethernet, 4DI/2DO	
A9MEM3565	iEM3565 advanced multi-tariff energy meter & electrical parameter plus BACnet MS/TP comm port		METSEPM5561	Power Meter range 77 mm depth, control power to 480 V AC, CI 0.2S, 63rd harmonic, 1.1 MB, Modbus and Ethernet, MID cert	
	LVCTs	49	METSEPM5562	Power Meter range 77 mm depth, control power to 480 V AC, CI 0.2S, 63rd harmonic, 1.1 MB, RMICAN approved, HW lockable, 4DI/2DO	
LVCT00050S	CT, split-core, Size 0, 50 A to 0.333 V		METSEPM5562MC	Power Meter range 77 mm depth, control power to 480 V AC, CI 0.2S, 63rd harmonic, 1.1 MB, RMICAN approved, factory sealed, 4DI/2DO	
LVCT00101S	CT, split-core, Size 1, 100 A to 0.333 V		METSEPM5563*	Power Meter range 77 mm depth, control power to 480 V AC, CI 0.2S, 63rd harmonic, 1.1 MB, DIN mount, no display, 4DI/2DO	
LVCT00201S	CT, split-core, Size 1, 200 A to 0.333 V		METSEPM5563RD*	PM5500 power meter, ETH-serial + 4DI-2DO out, remote display	
LVCT00102S	CT, split-core, Size 2, 100 A to 0.333 V		METSEPM5RD*	Remote display for PM5563 power meter	
LVCT00202S	CT, split-core, Size 2, 200 A to 0.333 V		*METSEPM5563RD includes both METSEPM5563 and METSEPM5RD		
LVCT00302S	CT, split-core, Size 2, 300 A to 0.333 V		METSEPM51HK	Hardware kit for PM51XX (voltage, current, comms & IO connectors + moulding clips)	
LVCT00403S	CT, split-core, Size 3, 400 A to 0.333 V		METSEPM53HK	Hardware kit for PM53XX (voltage, current, comms & IO connectors + moulding clips)	
LVCT00603S	CT, split-core, Size 3, 600 A to 0.333 V		METSEPM51_3RSK	Revenue sealing kit for PM51XX & PM53XX (sealing covers for voltage & current connectors)	
LVCT00803S	CT, split-core, Size 3, 800 A to 0.333 V		METSEPM55HK	Hardware kit for PM55XX (voltage, current, comms & IO connectors + moulding clips)	
LVCT00804S	CT, split-core, Size 4, 800 A to 0.333 V		METSEPM55RSK	Revenue sealing kit for PM55XX (sealing covers for voltage & current connectors)	
LVCT01004S	CT, split-core, Size 4, 1000 A to 0.333 V			Cables	
LVCT01204S	CT, split-core, Size 4, 1200 A to 0.333 V		METSEPM5CAB3	Remote Display cable	
LVCT01604S	CT, split-core, Size 4, 1600 A to 0.333 V		DCEPCURJX5GYM	Category 5e, Patch Cord, UTP, 0.5 M, Grey	
LVCT02004S	CT, split-core, Size 4, 2000 A to 0.333 V		DCEPCURJ01GYM	Category 5e, Patch Cord, UTP, 1 M, Grey	
LVCT02404S	CT, split-core, Size 4, 2400 A to 0.333 V		DCEPCURJ02GYM	Category 5e, Patch Cord, UTP, 2 M, Grey	
	Basic Multi-Function Metering	58	DCEPCURJ03GYM	Category 5e, Patch Cord, UTP, 3 M, Grey	
	ION6200	59	DCEPCURJ05GYM	Category 5e, Patch Cord, UTP, 5 M, Grey	
M6200	PowerLogic ION6200 meter		DCEPCURJ10GYM	Category 5e, Patch Cord, UTP, 10 M, Grey	
	PM3000	66		Advanced Metering	104
METSEPM3200	PM3200 basic power meter			PM8000	106
METSEPM3210	PM3210 power meter with pulse output		METSEPM8240	DIN96 panel mount meter	
METSEPM3250	PM3250 power meter with RS485 port		METSEPM8243	DIN rail mount meter	
METSEPM3255	PM3255 power meter plus 2 digital inputs, 2 digital outputs with RS-485 port		METSEPM8244	DIN rail mount meter with remote display	
	PM5350/PM5350IB/PM5350PB/PM5350P	72	METSEPM89RD96	Remote display, 3 metre cable, mounting hardware for 30mm hole (nut & centering pin), mounting hardware for DIN96 cutout (92x92mm) adapter plate	
METSEPM5350	PM5350 Power & Energy meter with THD, alarming		METSEPM8000SK	Terminal covers for utility sealing	
METSEPM5350PB/IB	PM5350PB/IB		METSEPM5100	Power Meter range 72 mm depth, control power to 415 V AC, CI 0.5S, 15th harmonic, no communication, 1DO	
METSEPM5350P	PM5350 Power & Energy meter with THD, alarming, multi-tariff and individual harmonics		METSEPM5110	Power Meter range 72 mm depth, control power to 415 V AC, CI 0.5S, 15th harmonic, RS-485 Modbus, 1DO	
	PM5000	95	METSEPM5111	Power Meter range 72 mm depth, control power to 415 V AC, CI 0.5S, 15th harmonic, RS-485 Modbus, 1DO, MID cert	
METSEPM5100	Power Meter range 72 mm depth, control power to 415 V AC, CI 0.5S, 15th harmonic, no communication, 1DO		METSEPM5310	Power Meter range 72 mm depth, control power to 415 V AC, CI 0.5S, 31st harmonic, 256 kB, RS-485 Modbus, 2DI/2DO	
METSEPM5110	Power Meter range 72 mm depth, control power to 415 V AC, CI 0.5S, 15th harmonic, RS-485 Modbus, 1DO		METSEPM5310R	Power Meter range 72 mm depth, control power to 415 V AC, CI 0.5S, 31st harmonic, 256 kB, RJ45 LVCT, RS-485 Modbus, 2DI/2DO	
METSEPM5111	Power Meter range 72 mm depth, control power to 415 V AC, CI 0.5S, 15th harmonic, RS-485 Modbus, 1DO, MID cert		METSEPM5320	Power Meter range 72 mm depth, control power to 415 V AC, CI 0.5S, 31st harmonic, 256 kB, Ethernet, 2DI/2DO	
METSEPM5310	Power Meter range 72 mm depth, control power to 415 V AC, CI 0.5S, 31st harmonic, 256 kB, RS-485 Modbus, 2DI/2DO		METSEPM5320R	Power Meter range 72 mm depth, control power to 415 V AC, CI 0.5S, 31st harmonic, 256 kB, RJ45 LVCT, Ethernet, 2DI/2DO	
METSEPM5310R	Power Meter range 72 mm depth, control power to 415 V AC, CI 0.5S, 31st harmonic, 256 kB, RJ45 LVCT, RS-485 Modbus, 2DI/2DO				
METSEPM5320	Power Meter range 72 mm depth, control power to 415 V AC, CI 0.5S, 31st harmonic, 256 kB, Ethernet, 2DI/2DO		METSECA1	Display Cable, 1 metre	
METSEPM5320R	Power Meter range 72 mm depth, control power to 415 V AC, CI 0.5S, 31st harmonic, 256 kB, RJ45 LVCT, Ethernet, 2DI/2DO		METSECA3	Display Cable, 3 metres	
			METSECA10	Display Cable, 10 metres	
			METSEPM8HWK	PM8000 hardware kit	
			METSEPM8RDHWK	PM8000 remote display hardware kit	
			METSEPM89M2600	Digital I/O module (6 digital inputs & 2 relay outputs)	

PowerLogic Commercial Reference Numbers

Commercial ref. no.	Description	Page
METSEPM89M0024	Analog I/O module (4 analog inputs & 2 analog outputs)	
	ION9000	116
METSEION92030	ION9200 meter, DIN mount, no display, HW kit	
METSEION92040	ION9200 meter, DIN mount, 192 mm display, B2B adapter, HW kit	
METSEION95030	ION9000T HSTC meter, DIN mount, no display, hardware kit	
METSEION95040	ION9000T HSTC meter, DIN mount, 192 mm display, B2B adapter, hardware kit	
METSEPM89RD96	Remote display, color LCD, 96 x 96 mm	
METSERD192	Remote display, color touchscreen, 192 x 192 mm	
METSEPM89M2600	I/O module, 2 relay outputs, 6 digital inputs	
METSEPM89M0024	I/O module, 2 analog outputs, 4 analog inputs	
METSE9HWK	ION9000 meter hardware kit – plugs, terminal guards, spare grounding screw, DIN clips	
METSERD192HWK	RD192 remote display hardware kit	
METSE9B2BMA	ION9000 B2B adapter	
METSE92040DEMOK	ION9000 Demo Kit	
METSE9USBK	ION9000 USB cover hardware kit	
METSE9CTHWK	ION9000 Current Input hardware kit – terminal screws, CT covers	
METSEPMBATK	Battery replacement kit – ION7400/ION9000/PM8000	
METSE7x4MAK	ION7x50 Mounting Adapter Kit	
	Advanced Utility Metering	127
	ION7400	128
METSEION7400	ION7400 Panel mount meter (integrated display with optical port and 2 energy pulse LEDs)	
METSEION7403	DIN rail mount - utility meter base	
METSEPM89RD96	Remote display, 3 m cable, mounting hardware for 30 mm hole and DIN96 cutout (92 x 92 mm) adapter plate	
METSEPM89M2600	Digital I/O module (6 digital inputs (wetted) & 2 relay outputs)	
METSEPM89M0024	Analog I/O module (4 analog inputs & 2 analog outputs)	
METSEPM8000SK	Revenue sealing kit	
METSECAB10	Display Cable, 10 m	
	ION8650	138
M8650A	ION8650A meter	
M8650B	ION8650B meter	
M8650C	ION8650C meter	
A-BASE-ADAPTER-9	Form 9S to Form 9A adapter	
A-BASE-ADAPTER-35	Form 35S to Form 35A adapter	
CBL-8X00BRKOUT	Break out cable 1.5 m	
CBL-8X00IOE5FT	Cable para I/O expander 1.5 m	
CBL-8X00IOE15FT	I/O extension cable 4.6 m	
CBL-8XX0-BOP-IOBOX	Cat.3 25PR UTP cable 205 m reel	
	ION8800	148
M8800A	ION8800A meter	
M8800B	ION8800B meter	
M8800C	ION8800C meter	
OPTICAL-PROBE	ION8800 optical probe with DB9 connector	
OPTICAL-PROBE-USB	ION8800 optical probe with USB connector	
	Multi-Circuit Metering	157
	BCPM (Branch Circuit Power Meter)	158
BCPMA084S	84-circuit solid-core power & energy meter, 100A CTs (4 strips), 19.05 mm spacing	
BCPMA184S	84-circuit solid-core power & energy meter, 100A CTs (4 strips), 25.4 mm spacing	
BCPMA042S	42-circuit solid-core power & energy meter, 100A CTs (2 strips), 19.05 mm spacing	
BCPMA142S	42-circuit solid-core power & energy meter, 100A CTs (2 strips), 25.4 mm spacing	

Commercial ref. no.	Description	Page
BCPMA224S	24-circuit solid-core power & energy meter, 100A CTs (2 strips), 18 mm spacing	
BCPMA236S	36-circuit solid-core power & energy meter, 100A CTs (2 strips), 18 mm spacing	
BCPMA242S	42-circuit solid-iEM2000core power & energy meter, 100 A CTs (2 strips), 18 mm spacing	
BCPMA248S	48-circuit solid-core power & energy meter, 100 A CTs (4 strips), 18 mm spacing	
BCPMA272S	72-circuit solid-core power & energy meter, 100 A CTs (4 strips), 18 mm spacing	
BCPMA284S	84-circuit solid-core power & energy meter, 100 A CTs (4 strips), 18 mm spacing	
BCPMB084S	84-circuit solid-core branch current, mains power meter, 100 A CTs (4 strips), 19.05 mm spacing	
BCPMB184S	84-circuit solid-core branch current, mains power meter, 100 A CTs (4 strips), 25.4 mm spacing	
BCPMB042S	42-circuit solid-core branch current, mains power meter, 100 A CTs (2 strips), 19.05 mm spacing	
BCPMB142S	42-circuit solid-core branch current, mains power meter, 100 A CTs (2 strips), 25.4 mm spacing	
BCPMB224S	24-circuit solid-core branch current, mains power meter, 100 A CTs (2 strips), 18 mm spacing	
BCPMB236S	36-circuit solid-core branch current, mains power meter, 100 A CTs (2 strips), 18 mm spacing	
BCPMB242S	42-circuit solid-core branch current, mains power meter, 100 A CTs (2 strips), 18 mm spacing	
BCPMB248S	48-circuit solid-core branch current, mains power meter, 100 A CTs (4 strips), 18 mm spacing	
BCPMB272S	72-circuit solid-core branch current, mains power meter, 100 A CTs (4 strips), 18 mm spacing	
BCPMB284S	84-circuit solid-core branch current, mains power meter, 100 A CTs (4 strips), 18 mm spacing	
BCPMC084S	84-circuit solid-core branch current meter, 100 A CTs (4 strips), 19.05 mm spacing	
BCPMC184S	84-circuit solid-core branch current meter, 100 A CTs (4 strips), 25.4 mm spacing	
BCPMC042S	42-circuit solid-core branch current meter, 100 A CTs (2 strips), 19.05 mm spacing	
BCPMC142S	42-circuit solid-core branch current meter, 100 A CTs (2 strips), 25.4 mm spacing	
BCPMC224S	24-circuit solid-core branch current meter, 100 A CTs (2 strips), 18 mm spacing	
BCPMC236S	36-circuit solid-core branch current meter, 100 A CTs (2 strips), 18 mm spacing	
BCPMC242S	42-circuit solid-core branch current meter, 100 A CTs (2 strips), 18 mm spacing	
BCPMC248S	48-circuit solid-core branch current meter, 100 A CTs (4 strips), 18 mm spacing	
BCPMC272S	72-circuit solid-core branch current meter, 100 A CTs (4 strips), 18 mm spacing	
BCPMC284S	84-circuit solid-core branch current meter, 100 A CTs (4 strips), 18 mm spacing	
BCPME042S	42-circuit solid-core power & energy meter w/Ethernet, 100 A CTs (2 strips), 19.05 mm spacing	
BCPME084S	84-circuit solid-core power & energy meter w/Ethernet, 100 A CTs (4 strips), 19.05 mm spacing	
BCPME142S	42-circuit solid-core power & energy meter w/Ethernet, 100 A CTs (2 strips), 25.4 mm spacing	
BCPME184S	84-circuit solid-core power & energy meter w/Ethernet, 100 A CTs (4 strips), 25.4 mm spacing	
BCPME224S	24-circuit solid-core power & energy meter w/Ethernet, 100 A CTs (2 strips), 18 mm spacing	
BCPME236S	36-circuit solid-core power & energy meter w/Ethernet, 100 A CTs (2 strips), 18 mm spacing	

PowerLogic Commercial Reference Numbers

Commercial ref. no.	Description	Page	Commercial ref. no.	Description	Page
BCPME242S	42-circuit solid-core power & energy meter w/Ethernet, 100 A CTs (2 strips), 18 mm spacing		BCPMSCT1	BCPM 100 A split core CTs, Quantity 6, 1.8 m lead lengths	
BCPME248S	48-circuit solid-core power & energy meter w/Ethernet, 100 A CTs (4 strips), 18 mm spacing		BCPMSCT1R20	BCPM 100 A split core CTs, Quantity 6, 6 m lead lengths	
BCPME272S	72-circuit solid-core power & energy meter w/Ethernet, 100 A CTs (4 strips), 18 mm spacing		BCPMSCT3	BCPM 200 A split core CTs, Quantity 1, 1.8 m lead lengths	
BCPME284S	84-circuit solid-core power & energy meter w/Ethernet, 100 A CTs (4 strips), 18 mm spacing		BCPMSCT3R20	BCPM 200 A split core CTs, Quantity 1, 6 m lead lengths	
BCPMSCA1S	42-circuit split-core power and energy meter, CTs and cables sold separately		BCPMCOVERS	BCPM circuit board cover	
BCPMSCA2S	84-circuit split-core power and energy meter, CTs and cables sold separately		BCPMREPAIR	CT repair kit for solid core BCPM (includes one CT)	
BCPMSCA30S	30-circuit split-core power and energy meter, (30) 50 A CTs & (2) 1.21 m cables		H6803R-0100	H6803R-0100 Additional 100A split core CT for use with solid core repair kit	
BCPMSCA42S	42-circuit split-core power and energy meter, (42) 50 A CTs & (2) 1.21 m cables		E8951	Modbus to BACnet protocol converter	
BCPMSCA60S	60-circuit split-core power and energy meter, (60) 50 A CTs & (4) 1.21 m cables		CBL008	Flat Ribbon cable for BCPM, length = 0.45 m	
BCPMSCA84S	84-circuit split-core power and energy meter, with (84) 50 A CTs & (4) 1.21 m cables		CBL016	Flat Ribbon cable for BCPM, length = 1.2 m	
BCPMSCB1S	42-circuit split-core branch current, mains power meter, CTs and cables sold separately		CBL017	Flat Ribbon cable for BCPM, length = 1.5 m	
BCPMSCB2S	84-circuit split-core branch current, mains power meter, CTs and cables sold separately		CBL018	Flat Ribbon cable for BCPM, length = 1.8 m	
BCPMSCB30S	30-circuit split-core branch current, mains power meter, (30) 50 A CTs & (2) 1.21 m cables		CBL019	Flat Ribbon cable for BCPM, length = 2.4 m	
BCPMSCB42S	42-circuit split-core branch current, mains power meter, (42) 50 A CTs & (2) 1.21 m cables		CBL020	Flat Ribbon cable for BCPM, length = 3.0 m	
BCPMSCB60S	60-circuit split-core branch current, mains power meter, (60) 50 A CTs & (4) 1.21 m cables		CBL021	Flat Ribbon cable for BCPM, length = 6.1 m	
BCPMSCBY63S	42-circuit split-core branch current, mains, all boards on backplate, CTs and cables sold separately		CBL022	Round Ribbon cable for BCPM, length = 1.2 m	
BCPMSCB84S	84-circuit split-core branch current, mains power meter, (84) 50 A CTs & (4) 1.21 m cables		CBL023	Round Ribbon cable for BCPM, length = 3 m	
BCPMSCC1S	42-circuit split-core current meter, CTs and cables sold separately		CBL024	Round Ribbon cable for BCPM, length = 6.1 m	
BCPMSCC2S	84-circuit split-core current meter, CTs and cables sold separately		CBL031	Round Ribbon cable for BCPM, length = 0.5 m	
BCPMSCC30S	30-circuit split-core current meter, (30) 50 A CTs & (2) 1.21 m cables		CBL033	Round Ribbon cable for BCPM, length = 0.8 m	
BCPMSCC42S	42 circuit split-core current meter, (42) 50 A CTs & (2) 1.21 m cables		LVCT00050S	50 A 10 mm x 11 mm	
BCPMSCC60S	60-circuit split-core current meter, (60) 50 A CTs & (4) 1.21 m cables		LVCT00101S	100 A 16 mm x 20 mm	
BCPMSCCY63S	42-circuit split-core current meter, all boards on backplate, CTs and cables sold separately		LVCT00102S	100 A 30 mm x 31 mm	
BCPMSCC84S	84-circuit split-core current meter, (84) 50 A CTs & (4) 1.21 m cables		LVCT00202S	200 A 30 mm x 31 mm	
BCPMSCCE1S	42-circuit split-core power and energy meter w/Ethernet, CTs and cables sold separately		LVCT00302S	300 A 30 mm x 31 mm	
BCPMSCCE2S	84-circuit split-core power and energy meter w/Ethernet, CTs and cables sold separately		LVCT00403S	400 A 62 mm x 73 mm	
BCPMSCCE30S	30-circuit split-core power and energy meter w/Ethernet, (30) 50A CTs & (2) 1.21 m cables		LVCT00603S	600 A 62 mm x 73 mm	
BCPMSCCE42S	42-circuit split-core power and energy meter w/Ethernet, (42) 50 A CTs & (2) 1.21 m cables		LVCT00803S	800 A 62 mm x 73 mm	
BCPMSCCE60S	60-circuit split-core power and energy meter w/Ethernet, (60) 50 A CTs & (4) 1.21 m cables		LVCT00804S	800 A 62 mm x 139 mm	
BCPMSCCE84S	84-circuit split-core power and energy meter w/Ethernet, (84) 50 A CTs & (4) 1.21 m cables		LVCT01004S	1000 A 62 mm x 139 mm	
BCPMSCADPBS	BCPM adapter boards, quantity 2, for split core BCPM		LVCT01204S	1200 A 62 mm x 139 mm	
BCPMSCCT0	BCPM 50 A split core CTs, Quantity 6, 1.8 m lead lengths		LVCT01604S	1600 A 62 mm x 139 mm	
BCPMSCCT0R20	BCPM 50 A split core CTs, quantity 6, 6 m lead lengths		LVCT02004S	2000 A 62 mm x 139 mm	
			LVCT02404S	2400 A 62 mm x 139 mm	
			LVCT20050S	50 A 10 mm	
			LVCT20100S	100 A 10 mm	
			LVCT20202S	200 A 25 mm	
			EM4000		172
			METSEEM403316	24 x 333 mV inputs, 120V control power 60 Hz	
			METSEEM403336	24 x 333 mV inputs, 277V control power 60 Hz	
			METSEEM408016	24 x 80 mA inputs, 120V control power 60 Hz	
			METSEEM408036	24 x 80 mA inputs, 277V control power 60 Hz	
			METSECONV580	EM4000 5 A : 80 mA converter	
			METSEPTMOD480	480 V PT Module for EM4X00 meter	
			METSEPTMOD347600	347 V/600 V PT Module for EM4X00 meter	
			METSECTTERM	EM4000 CT termination module	
			METSECTSHORT	EM4000 CT shorting module	
			METSECT80200	EM4000 solid-core CT 200 A / 80 mA secondary	
			METSECT80400	EM4000 solid-core CT 400 A / 80 mA secondary	
			METSECT80600	EM4000 solid-core CT 600 A / 80 mA secondary	
			EM4800		181
			METSEEM480525	24 x 5 A inputs, 230/240 V control power, 50 Hz	
			METSEEM480516	24 x 5 A inputs, 120 V control power, 60 Hz	
			METSEEM483325	24 x 333 mV inputs, 230/240 V control power, 50 Hz	
			METSEEM483316	24 x 333 mV inputs, 120 V control power, 60 Hz	
			METSEEM488016	24 x 80 mA inputs, 120 V control power, 60 Hz	

PowerLogic Commercial Reference Numbers

Commercial ref. no.	Description	Page
METSEEM488026	24 x 80 mA inputs, 230/240 V control power, 50 Hz	
METSECONV580	EM4000 5 A : 80 mA converter	
METSEPTMOD480	480 V PT Module for EM4X00 meter	
METSEPTMOD347600	347 V/600 V PT Module for EM4X00 meter	
METSECTTERM	EM4000 CT termination module	
METSECTSHORT	EM4000 CT shorting module	
METSECT80200	EM4000 solid-core CT 200 A / 80 mA secondary	
METSECT80400	EM4000 solid-core CT 400 A / 80 mA secondary	
METSECT80600	EM4000 solid-core CT 600 A / 80 mA secondary	
	EM4900	186
METSEEM4904A	EM4900 (4) 3-phase meters - Modbus RTU only	
METSEEM4908A	EM4900 (8) 3-phase meters - Modbus RTU only	
METSEEM4914A	EM4900 (14) 3-phase meters - Modbus RTU only	
METSEEM4928A	EM4900 (28) 3-phase meters - Modbus RTU only	
METSEEM4904E	EM4900 (4) 3-phase meters - Ethernet and Serial (Modbus, BACnet & SNMP)	
METSEEM4908E	EM4900 (8) 3-phase meters - Ethernet and Serial (Modbus, BACnet & SNMP)	
METSEEM4914E	EM4900 (14) 3-phase meters - Ethernet and Serial (Modbus, BACnet & SNMP)	
METSEEM4928E	EM4900 (28) 3-phase meters - Ethernet and Serial (Modbus, BACnet & SNMP)	
	Retrofit & Wireless Products	195
	EM3500	197
METSEEM3502	EM3502 Pulse out only	
METSEEM3550	EM3550 Modbus - 2 quadrant	
METSEEM3555	EM3555 Modbus - 4 quadrant with logging	
METSEEM3560	EM3560 BACnet with logging	
METSEEM3502A	EM3502A Pulse Rope CT model	
METSEEM3550A	EM3550A Modbus Rope CT Model	
METSEEM3560A	EM3560A BACnet w/ logging Rope CT Model	
METSEEM3561	EM3561 BACnet without logging	
METSEEM3561A	EM3561A BACnet without logging Rope CT Model	
	EM4200	203
METSEEM4235	Enercept, Class 0.2S meter, Modbus/BACnet communication, Uni-Directional/Bi-Directional, RS-485, IEC wire code, single circuit, Modbus/BACnet	
METSEEM4236	Enercept, Class 0.2S meter, Modbus/BACnet communication, Uni-Directional/Bi-Directional, RS-485, ANSI wire code, single circuit, Modbus/BACnet	
	Communications & Gateways	221
	Link150 Ethernet gateway	225
EGX150	Link150 Ethernet gateway	
	Com'X 200/210/510	229
EBX200	Com'X 200 data logger 24 V DC or 230 V AC power supplied	
EBX210	Com'X 210 data logger 24 V DC power supplied UL rated	
EBX510	Com'X 510 energy server 24 V DC power supplied UL rated	
EBXA-GPRS-SIM	Com'X GPRS interface SIM card	
EBXA-ANT-5M	Com'X External GPRS antenna	
EBXA-USB-Zigbee	Com'X Zigbee USB interface	
	ION7550 RTU	239
M7550	ION7550 RTU	
M7550A0N9B9A0A0A	7550-I/5M/512S-RTU-P240-SCOM PML 7550 PO	
M7550A0N9B9E0A0A	SE-7550-I/5M/512S-RTU-P240-ETH PML 7550	
M7550A0N9B9E0E0A	SE-7550-I/5M/512S-RTU-P240-ETH-20MAI PML	

Commercial ref. no.	Description	Page
	Insulation Monitoring	248
	Vigilohm Insulation Monitoring	249
50310	Case XGR(230 V CA) +XRM+3Clamp-on CTs	
50281	XGR 115-127 V CA	
50282	XGR 220-240 V CA	
50283	XGR 380-415 V CA	
50278	XRM	
50494	XP15 Clamp-on toroid for XRM	
50498	XP50 Clamp-on toroid for XRM	
50499	XP100 Clamp-on toroid for XRM	
50285	Empty case	
50170	Surge arrester CARDEW 250 V CA	
50171	Surge arrester CARDEW 440 V CA	
50172	Surge arrester CARDEW 660 V CA	
50183	Surge arrester CARDEW 1000 V CA	
50169	Base CARDEW	
50248	PHT1000	
50159	ZX resistance grounded	
IMD-IM20-1700	Voltage Adaptor for IM20	
IMD-IM400-1700	Voltage Adaptor for IM400	
IMD-IM400-1700C	Voltage Adaptor for IM400C	
IMD-IM400VA2	Voltage adaptor for PV application_Coated	
50168	HOSPITAL REMOTE PANEL	
50540	XM300C 115-127 V CA	
50541	XM300C 200-240 V CA	
50542	XM300C 380-415 V CA	
IMD-IM10	IM10	
IMD-IM10-H	IM10 H	
IMD-IM20	IM20	
IMD-IM20-H	IM20 H	
IMD-IM9	IM9	
IMD-IM9-OL	IM9Off-Line	
IMD-IM400	IM400	
IMD-IM400C	IM400C	
50490	XML308 115-127 V CA	
50491	XML308 220-240 V CA	
50492	XML308 380-415 V CA	
50322	XML316 115-127	
50323	XML316 220-240 V CA	
50324	XML316 380-415 V CA	
50606	XL308 115/127 V CA	
50607	XL308 220-240 V CA	
50608	XL308 380-415 V CA	
50615	XL316 115/127 V CA	
50616	XL316 220-240 V CA	
50617	XL316 380-415 V CA	
50723	XD308C 115-127 V CA	
50724	XD308C 220-240 V CA	
50725	XD308C 380-415 V CA	
50506	XD301 115-127 V CA	
50507	XD301 220-240 V CA	
50508	XD301 380-415 V CA	
50535	XD312 115-127 V CA	
50536	XD312 220-240 V CA	
50537	XD312 380-415 V CA	
50536-H	XD312 220-240 V CA FOR HOSPITAL	
50515	XLI300 115/127 V CA	

PowerLogic Commercial Reference Numbers

Commercial ref. no.	Description	Page	Commercial ref. no.	Description	Page
50516	XLI300 220/240 V CA		PSA109923	PowerSCADA DVD	
50517	XLI300 380/415 V CA		PSA109924	PowerSCADA Software Key	
50545	XTU300115/127 V CA		PSA101113	PowerSCADA Server, 1500 Points	
50546	XTU300 220/240 V CA		PSA101114	PowerSCADA Server, 5000 Points	
50547	XTU300 380/415 V CA		PSA101115	PowerSCADA Server, 15000 Points	
50437	Toroid TA30		PSA101199	PowerSCADA Server, Unlimited Points	
50438	Toroid PA50		PSA102013	PowerSCADA Control Client, 1500 Points	
50439	Toroid IA80		PSA102014	PowerSCADA Control Client, 5000 Points	
50440	Toroid MA120		PSA102015	PowerSCADA Control Client, 15000 Points	
50441	Toroid SA200		PSA102099	PowerSCADA Control Client, Unlimited Points	
50442	Toroid GA300		PSA103099	PowerSCADA View-only Client, Unlimited Points	
50485	Toroid Ouvert POA		PSA105100	PowerSCADA Anywhere, 5 User Pack	
50486	Toroid Ouvert GOA		PSA104112	Advanced Reporting and Dashboards Module	
50420	Toroid ouvert TOA80		PSA104113	Event Notification Module	
50421	Toroid ouvert TOA120		PSA104114	Billing Module	
	Power Monitoring Software	253	PSA104115	Breaker Performance Module	
	EcoStruxure™ Power Monitoring Expert	254	PSA104116	Energy Analysis Module	
	Server & Options		PSA104118	EPSS Test Module	
PSWSANCZZSPEZZ	PME Standard Edition BASE licence (includes 1 Engineering Client)		PSA104119	UPS Performance Module	
PSWSONCZZSPEZZ	OPC DA Server for PME software		PSA104120	Generator Performance Module	
PSWSQL2016L	SQL Server Standard Edition Licence - 2 Core pack		PSA104121	Power Capacity Module	
PSWMVNCZZSPEZZ	Event Notification module for PME software		PSA104122	Power Efficiency Module	
	Client Licences (System users)		PSA104123	IT Billing Module	
PSWCENCZZNPEZZ	Engineering Client for Power Monitoring Expert software		PSA104124	Power Quality Advisor Module	
PSWCWNCZZNPEZZ	Web Client for PME software		PSA109103	PowerSCADA Connected ULTRA Service Plan	
PSWCZNCZZSPEZZ	Unlimited Engineering and Web Clients for PME software		PSA109102	PowerSCADA Connected PRIME Service Plan	
	Device Licences (Connected devices)		Please see your Schneider Electric Representative for complete ordering information.		
PSWDENCZZNPEZZ	Entry-Range Device for PME software				
PSWDMNCZZNPEZZ	Mid-Range Device for PME software				
PSWDSNCZZNPEZZ	High-End Device for PME software				
PSWDZNCZZSPEZZ	Unlimited Devices for PME software				
	Device Licences (Connected devices) US, India, & Canada				
PSWDANCZZNPEZZ	5 Device Pack for PME software				
PSWDBNCZZNPEZZ	25 Device Pack for PME software				
PSWDCNCZZNPEZZ	50 Device Pack for PME software				
PSWDDNCZZNPEZZ	100 Device Pack for PME software				
PSWDFNCZZNPEZZ	200 Device Pack for PME software				
PSWDZNCZZSPEZZ	Unlimited Device Pack for PME software				
	Optional Software Modules				
PSWMBNCZZSPEZZ	Billing Module for PME software				
PSWMXNCZZSPEZZ	Breaker Performance Module for PME software				
PSWMZNCZZSPEZZ	Energy Analysis Module for PME software				
PSWMENCZZSPEZZ	EPSS Module for PME software				
PSWMPNPAZSPEZZ	Generator Performance Module PME software				
PSWMNPAZSPEZZ	IT Billing Module for PME software				
PSWMPNCZZSPEZZ	Power Capacity Module for PME software				
PSWMNCCZZSPEZZ	Power Efficiency Module for PME software				
PSWMUNCZZSPEZZ	UPS Performance Module for PME software				
	EcoStruxure™ Power SCADA Operation	260			
PSA109922	PowerSCADA DVD and USB key				
PSA109921	PowerSCADA Additional USB Key				

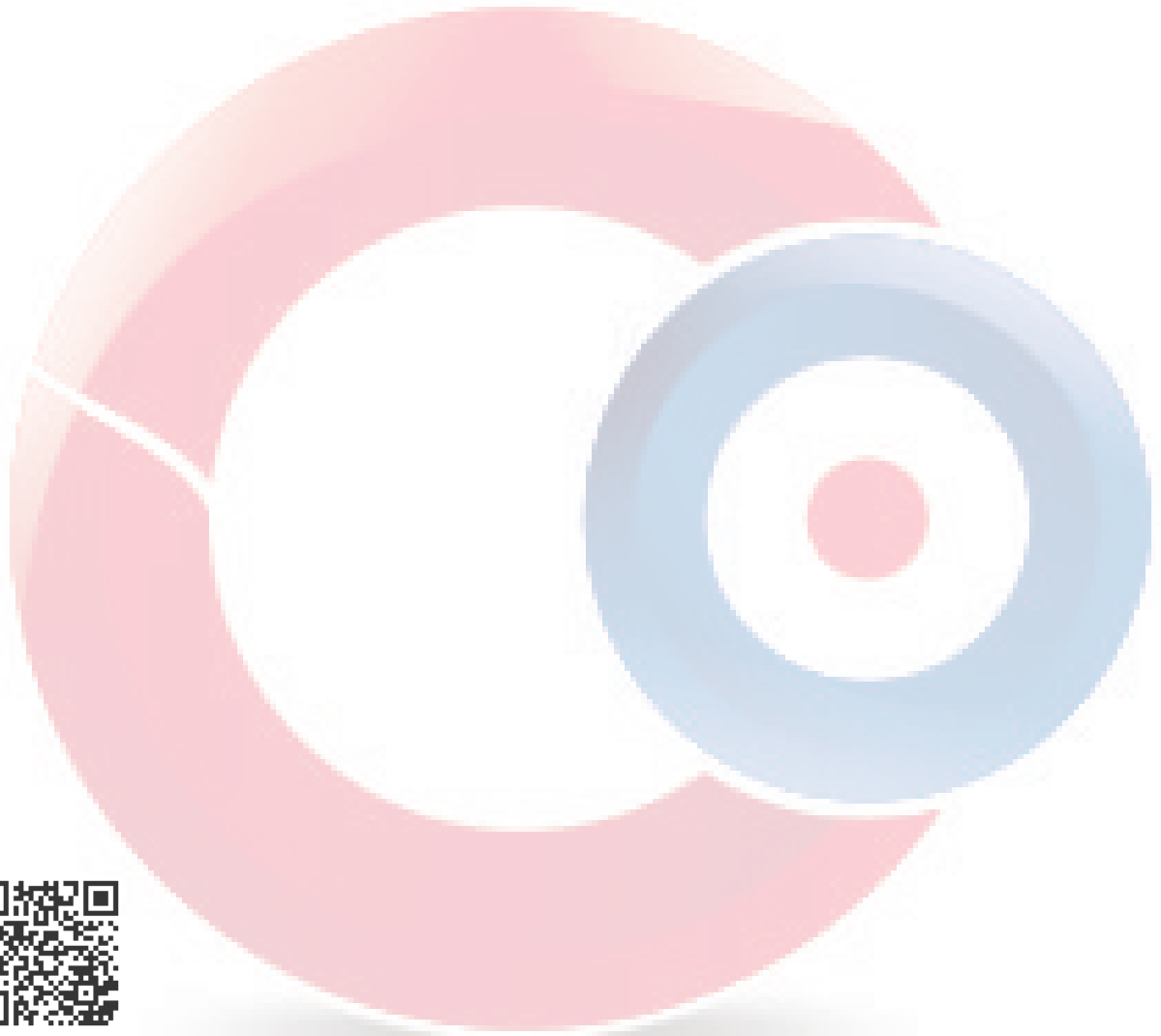

www.se.com

Schneider Electric Industries SAS
35, Rue Joseph Monier
CS 30323
92506 Rueil Malmaison Cedex

RCS Nanterre 954 503 439
Capital social 928 298 512 €
www.se.com

September, 2019
PowerLogic™ Catalogue
PLSED309005EN

© 2019 - Schneider Electric. All rights reserved.
All trademarks are owned by Schneider Electric
Industries SAS or its affiliated companies.

optimizar

As standards, specifications and designs develop from time to time, please
ask for confirmation of the information given in this document.

Over 75 % of Schneider Electric products
have been awarded the Green Premium ecolabel.

